

FS100 MAINTENANCE MANUAL

Upon receipt of the product and prior to initial operation, read these instructions thoroughly, and retain for future reference.

MOTOMAN INSTRUCTIONS

- MOTOMAN-□□□ INSTRUCTIONS
- FS100 INSTRUCTIONS
- FS100 OPERATOR'S MANUAL
- FS100 MAINTENANCE MANUAL

Part Number: 159645-1CD
Revision: 4

Copyright © 2015, Yaskawa America, Inc. All Rights Reserved.



MANDATORY

- This manual explains maintenance procedures of the FS100 system. Read this manual carefully and be sure to understand its contents before handling the FS100.
- General items related to safety are listed in Chapter 1: Safety of the FS100 INSTRUCTIONS. To ensure correct and safe operation, carefully read the FS100 Instructions before reading this manual.



CAUTION

- Some drawings in this manual are shown with the protective covers or shields removed for clarity. Be sure all covers and shields are replaced before operating this product.
- The drawings and photos in this manual are representative examples and differences may exist between them and the delivered product.
- YASKAWA may modify this model without notice when necessary due to product improvements, modifications, or changes in specifications. If such modification is made, the manual number will also be revised.
- If your copy of the manual is damaged or lost, contact a YASKAWA representative to order a new copy. The representatives are listed on the back cover. Be sure to tell the representative the manual number listed on the front cover.
- YASKAWA is not responsible for incidents arising from unauthorized modification of its products. Unauthorized modification voids your product's warranty.

Notes for Safe Operation

Read this manual carefully before installation, operation, maintenance, or inspection of the FS100 .

In this manual, the Notes for Safe Operation are classified as “DANGER”, “WARNING”, “CAUTION”, “MANDATORY”, or “PROHIBITED”.



DANGER

Indicates an imminent hazardous situation which, if not avoided, could result in death or serious injury to personnel.



WARNING

Indicates a potentially hazardous situation which, if not avoided, could result in death or serious injury to personnel.



CAUTION

Indicates a potentially hazardous situation which, if not avoided, could result in minor or moderate injury to personnel and damage to equipment. It may also be used to alert against unsafe practices.



MANDATORY

Always be sure to follow explicitly the items listed under this heading.



PROHIBITED

Must never be performed.

Even items described as “CAUTION” may result in a serious accident in some situations.

At any rate, be sure to follow these important items.



To ensure safe and efficient operation at all times, be sure to follow all instructions, even if not designated as “DANGER”, “WARNING” and “CAUTION” .



WARNING

- Before operating the manipulator, check that servo power is turned OFF when the emergency stop button on the programming pendant is pressed.
When the servo power is turned OFF, the SERVO ON LED on the programming pendant is turned OFF.

Injury or damage to machinery may result if the emergency stop circuit cannot stop the manipulator during an emergency. The manipulator should not be used if the emergency stop button does not function.

Figure 1: Emergency Stop Button



- In the case of not using the programming pendant, be sure to supply the emergency stop button on the equipment. Then before operating the manipulator, check to be sure that the servo power is turned OFF by pressing the emergency stop button.
Connect the external emergency stop button to the 5-6 pin and 16-17 pin of the robot system signal connector (CN2).
- Upon shipment of the FS100, this signal is connected by a jumper cable in the dummy connector. To use the signal, make sure to supply a new connector, and then input it.

If the signal is input with the jumper cable connected, it does not function, which may result in personal injury or equipment damage.

- Once the emergency stop button is released, clear the cell of all items which could interfere with the operation of the manipulator.
Then turn the servo power ON.

Injury may result from unintentional or unexpected manipulator motion.

Figure 2: Release of Emergency Stop Button



- Observe the following precautions when performing teaching operations within the manipulator's operating range:
 - Be sure to use a lockout device to the safeguarding when going inside. Also, display the sign that the operation is being performed inside the safeguarding and make sure no one closes the safeguarding.
 - View the manipulator from the front whenever possible.
 - Always follow the predetermined operating procedure.
 - Ensure that you have a safe place to retreat in case of emergency.

Improper or unintended manipulator operation may result in injury.



WARNING

- Confirm that no person is present in the manipulator's operating range and that you are in a safe location before:
 - Turning ON the power for the FS100.
 - Moving the manipulator with the programming pendant.
 - Running the system in the check mode.
 - Performing automatic operations.

Injury may result if anyone enters the manipulator's operating range during operation. Always press an emergency stop button immediately if there are problems.

The emergency stop button is located on the programming pendant.



CAUTION

- Perform the following inspection procedures prior to teaching the manipulator. If problems are found, correct them immediately, and be sure that all other necessary tasks have been performed.
 - Check for problems in manipulator movement.
 - Check for damage to the insulation and sheathing of external wires.
- Return the programming pendant to a safe place after use.

If the programming pendant is inadvertently left on the manipulator, on a fixture, or on the floor, the manipulator or a tool may collide with the programming pendant during manipulator movement, which may result in personal injury or equipment damage.

- Read and understand the Explanation of Warning Labels in the FS100 Instructions before operating the manipulator.

Definition of Terms Used Often in This Manual



The MOTOMAN is the YASKAWA industrial robot product.

The MOTOMAN usually consists of the manipulator, the FS100 controller, manipulator cables, the FS100 programming pendant (optional), and the FS100 programming pendant dummy connector (optional).

In this manual, the equipment is designated as follows:

Equipment	Manual Designation
FS100 controller	FS100
FS100 programming pendant	Programming pendant
Cable between the manipulator and the controller	Manipulator Cable
FS100 programming pendant dummy connector	Programming pendant dummy connector

Descriptions of the programming pendant keys, buttons, and displays are shown as follows:

Equipment		Manual Designation
Programming Pendant	Character Keys	The keys which have characters printed on them are denoted with []. ex. [ENTER]
	Symbol Keys	The keys which have a symbol printed on them are not denoted with [] but depicted with a small picture. ex. PAGE key  The Cursor is an exception, and a picture is not shown.
	Axis Keys Numeric Keys	"Axis Keys" and "Numeric Keys" are generic names for the keys for axis operation and number input.
	Keys pressed simultaneously	When two keys are to be pressed simultaneously, the keys are shown with a "+" sign between them, ex. SHIFT key  +COORD key 
	Mode Key	Three kinds of modes that can be selected by the mode key are denoted as follows: REMOTE, PLAY, or TEACH
	Button	Three buttons on the upper side of the programming pendant are denoted as follows: HOLD button START button EMERGENCY STOP button
	Displays	The menu displayed in the programming pendant is denoted with { }. ex. {JOB}
PC Keyboard		The name of the key is denoted ex. Ctrl key on the keyboard

Description of the Operation Procedure

In the explanation of the operation procedure, the expression "Select •••" means that the cursor is moved to the object item and the SELECT key is pressed, or that the item is directly selected by touching the screen.

Registered Trademark

In this manual, names of companies, corporations, or products are trademarks, registered trademarks, or brand names for each company or corporation. The indications of (R) and TM are omitted.

Explanation of Warning Labels

DANGER

• The label described below is attached to the manipulator.

Observe the precautions on the warning labels.

Failure to observe this caution may result in injury or damage to equipment.

Figure 3: Warning Labels

<p>WARNING Label A:</p> 	<p>WARNING Label B:</p> 
---	--

• The following warning labels are attached to FS100.

Observe the precautions on the warning labels.

Failure to observe this warning may result in injury or damage to equipment.

Figure 4: Location of Warning Labels

 <p>Top View</p>	 <p>Heavy Object Warning NP</p>
 <p>Front View</p>	 <p>Electric Shock Warning NP</p>  <p>Electric Shock Warning NP</p>

Table of Contents

1	Equipment Configuration	1-1
1.1	Arrangement of Units and Circuit Boards	1-1
1.2	Power Flow	1-2
1.3	Signal Flow.....	1-3
2	Security System	2-1
2.1	Protection Through Security Mode Settings	2-1
2.1.1	Security Mode	2-1
2.1.1.1	Changing the Security Mode	2-5
2.1.2	User ID	2-7
2.1.2.1	Changing a User ID.....	2-7
3	Maintenance and Inspections	3-1
3.1	Daily Inspections.....	3-1
3.2	Cooling Fan Inspections	3-3
3.3	Emergency Stop Button Inspections.....	3-4
3.4	Enable Switch Inspections.....	3-4
3.5	Battery Inspections	3-5
4	Preparation before Replacing Parts.....	4-1
4.1	Creating a Check Program	4-3
5	Replacing Parts.....	5-1
5.1	Fuse Replacement.....	5-1
5.2	Interior Circulation Fan Replacement	5-3
5.3	Battery Replacement	5-4
6	Recommended Spare Parts.....	6-1
6.1	List of Accessories.....	6-1
6.2	Recommended Spare Parts	6-2

7	Operations After Replacing Parts.....	7-1
7.1	Home Position Calibration	7-2
7.1.1	Home Position Calibration	7-2
7.1.2	Calibrating Operation.....	7-4
7.1.2.1	Registering All Axes at One Time.....	7-4
7.1.2.2	Registering Individual Axes	7-6
7.1.2.3	Changing the Absolute Data	7-7
7.1.2.4	Clearing Absolute Data.....	7-8
7.1.3	Manipulator Home Position.....	7-10
7.2	Position Deviation Check Using the Check Program.....	7-11
7.3	Checking of the Check Program	7-12
7.3.1	Motion of the Check Program	7-12
7.3.2	Checking of the Check Program.....	7-12
7.3.3	Home Position Data Correction	7-13
7.4	Setting the Second Home Position (Check Point)	7-14
7.4.1	Purpose of Position Check Operation.....	7-16
7.4.2	Procedure for the Second Home Position Setting (Check Point)	7-18
7.4.3	Procedure after the Alarm.....	7-19
8	System Diagnosis	8-1
8.1	System Version.....	8-1
8.2	Manipulator Model	8-1
8.3	Input/Output Status.....	8-2
8.3.1	Universal Input.....	8-2
8.3.1.1	Universal Input Window.....	8-2
8.3.1.2	Universal Input Simple Window.....	8-2
8.3.2	Universal Output	8-3
8.3.2.1	Universal Output Window	8-3
8.3.2.2	Universal Output Simple Window	8-3
8.3.2.3	Modifying the Output Status	8-4
8.3.3	Specific Input	8-5
8.3.3.1	Specified Input Window.....	8-5
8.3.3.2	Specific Input Simple Window	8-5
8.3.4	Specific Output	8-6
8.3.4.1	Specified Output Window	8-6
8.3.4.2	Specific Output Simple Window	8-6
8.3.5	RIN Input	8-7
8.3.5.1	RIN Input Window.....	8-7

8.3.6	Signal Number Search	8-8
8.3.6.1	Direct Search on the Universal/Specified Input/Output Window	8-9
8.3.6.2	Search from the Menu	8-10
8.3.7	Relay Number Search	8-11
8.3.7.1	Direct Search on the Universal/Specified Input/Output Window	8-12
8.3.7.2	Search from the Menu	8-13
8.3.8	Modification of the Signal Name	8-14
8.3.8.1	Direct Modification on the Universal/Specified Input/Output Window ...	8-14
8.3.8.2	Modification from the Menu	8-15
8.4	System Monitoring Time Display	8-16
8.4.1	System Monitoring Time Display Window	8-16
8.4.2	Individual Window of the System Monitoring Time Display	8-17
8.4.3	Clearing the System Monitoring Time Display	8-18
8.5	Alarm History	8-19
8.5.1	Alarm History Window	8-19
8.5.2	Clearing the Alarm History	8-20
8.6	I/O Message History	8-21
8.6.1	I/O Message History Window	8-21
8.6.1.1	Search	8-21
8.6.2	Clearing the I/O Message History	8-22
8.7	Position Data When Power is Turned ON/OFF	8-23
8.7.1	Power ON/OFF Position Window	8-23
8.8	Current Position	8-24
8.8.1	Current Position Window	8-24
8.9	Servo Monitoring	8-25
8.9.1	Servo Monitor Window	8-25
8.9.1.1	Changing the Monitor Items	8-26
8.9.1.2	Clearing Maximum Torque Data	8-28
9	Alarm	9-1
9.1	Outline of Alarm	9-1
9.2	Alarm Display	9-2
9.2.1	Displaying and Releasing Alarm	9-2
9.2.1.1	Releasing Alarms	9-2
9.2.2	Special Alarm Display	9-3

9.3	Display of Alarm Details.....	9-5
9.3.1	Parameter.....	9-5
9.3.2	Display of Alarm Detail Window.....	9-5
9.3.3	Transition of Alarm Detail Window.....	9-7
9.4	Alarm Message List.....	9-8
10	Error.....	10-1
10.1	Error Message.....	10-1
10.1.1	System and General Operation.....	10-2
10.1.2	Editing.....	10-5
10.1.3	Job Defined Data.....	10-6
10.1.4	External Memory Equipment.....	10-9
10.1.5	Concurrent I/O.....	10-14
10.1.6	Maintenance Mode.....	10-15
10.2	Particular Error Message.....	10-16
10.2.1	Message.....	10-16
10.2.1.1	Fatal Error.....	10-16
10.2.1.2	Application Transaction Error.....	10-17
10.2.1.3	Other Errors.....	10-17
10.2.2	When the Error is Indicated.....	10-18
10.2.2.1	Fatal Error.....	10-18
10.2.2.2	Application Transaction Error.....	10-18
10.2.2.3	Other Errors.....	10-18
11	LED Indicator on Each Circuit Board.....	11-1
11.1	6 LED-Spot Indicator on the Main CPU Circuit Board (CPU201R).....	11-2
11.2	7-Segment LED Indicator on the Main CPU Circuit Board (CPU201R).....	11-3
11.2.1	Status of 7-Segment LED Indicator at Error Occurrence.....	11-4
11.2.2	Status of 7-Segment LED Indicator at Control Power Start-up (one digit).....	11-5
11.2.3	Status of 7-Segment LED Indicator at Hardware Error Occurrence.....	11-5
11.2.4	Status of 7-Segment LED Indicator at Alarm Occurrence.....	11-6
11.3	7 SEG-LED Indicator on Machine Safety Board (SF2300).....	11-7
11.4	7 SEG-LED Indicator on SERVO Control Board (IFM).....	11-8
11.4.1	LED Indicator at Alarm Occurrence in the Main CPU and SERVO Control Board Communication System.....	11-8
11.4.2	LED Indicator During the Start-up Process.....	11-9

1 Equipment Configuration

1.1 Arrangement of Units and Circuit Boards

Fig. 1-1: Arrangement of Units and Circuit Boards

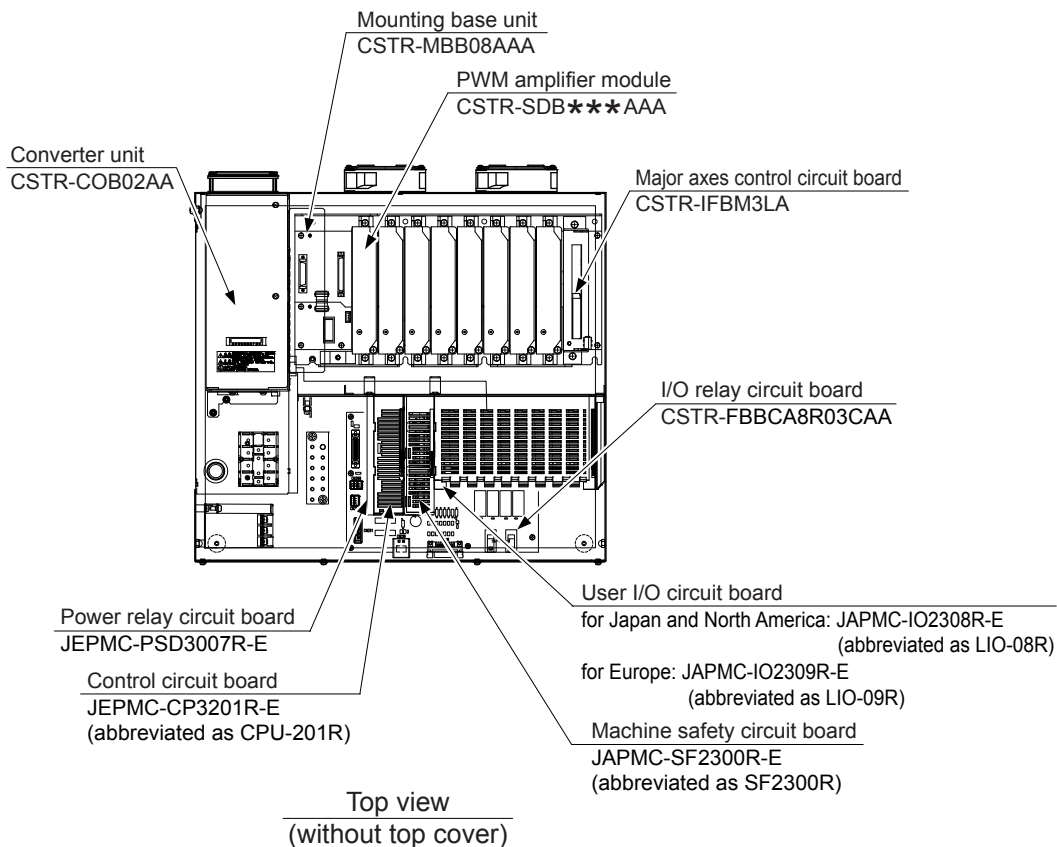

1.2 Power Flow

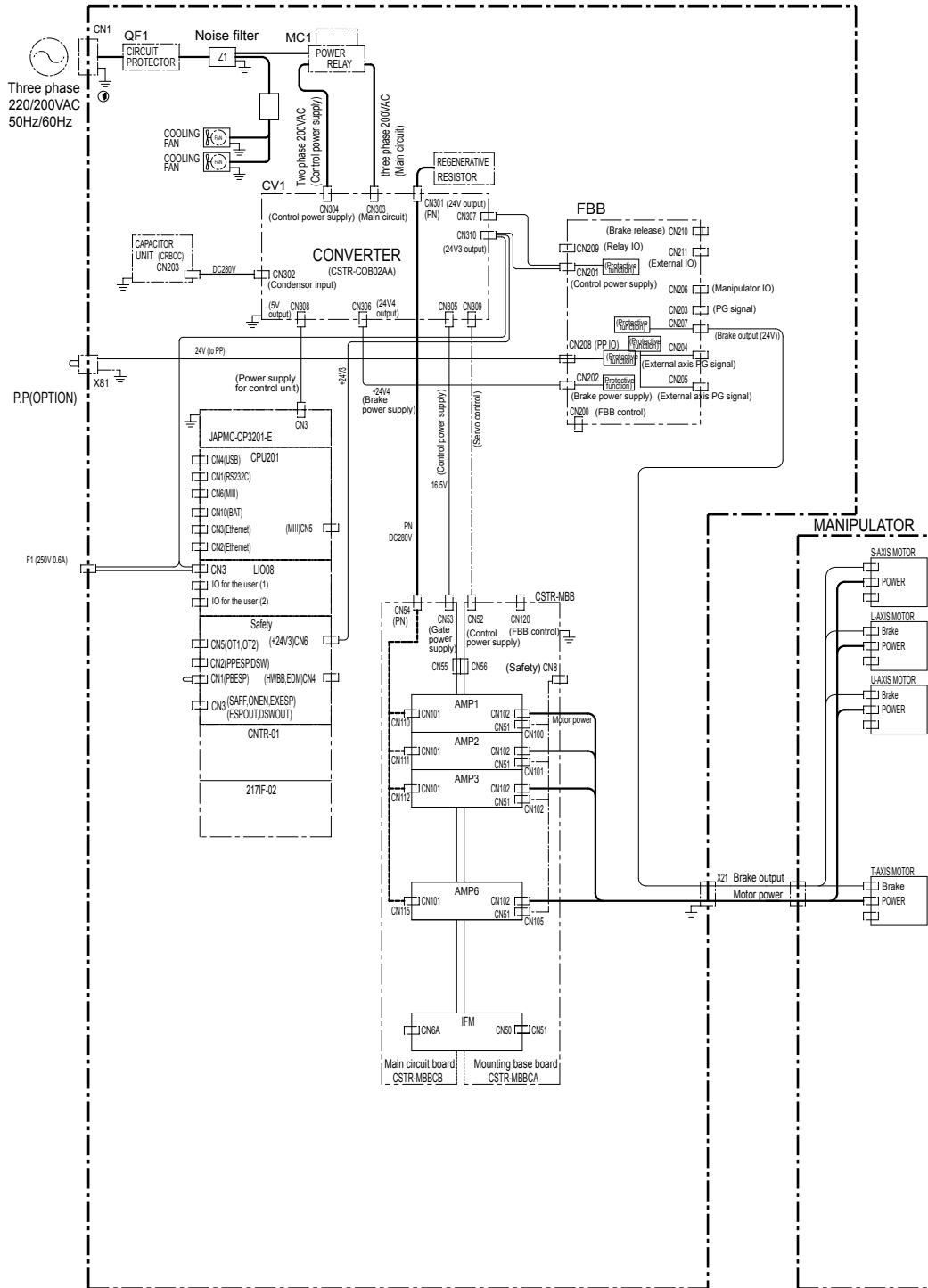

1.3 Signal Flow

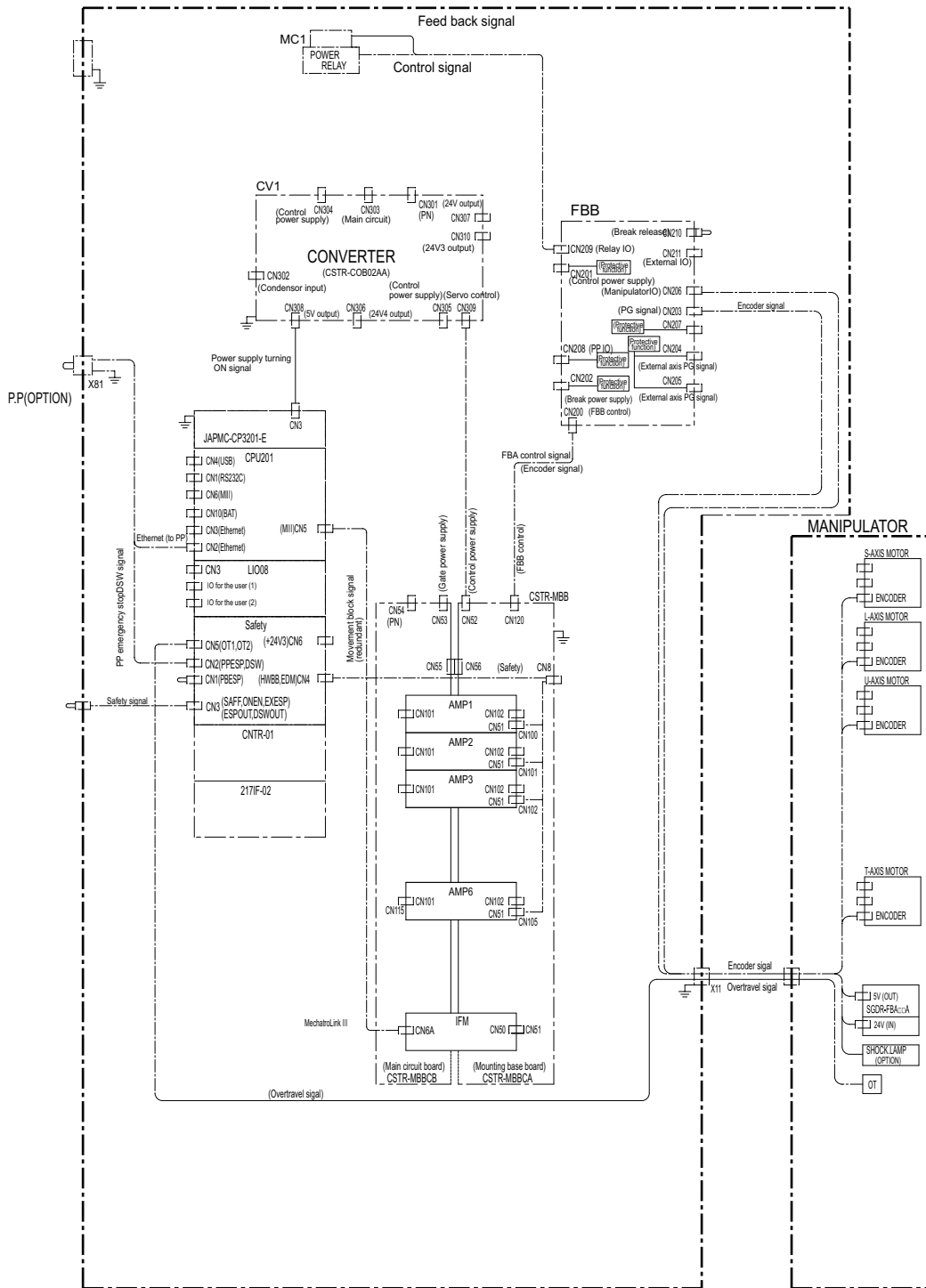

2 Security System

2.1 Protection Through Security Mode Settings

The FS100 modes setting are protected by a security system. The system allows operation and modification of settings according to operator clearance. Be sure operators have the correct level of training for each level to which they are granted access.

2.1.1 Security Mode

There are three security modes. Editing mode and management mode require a user ID. The user ID consists of numbers and letters, and contains no less than 4 and no more than 8 characters. (Significant numbers and signs: "0 to 9", "-", ".".

Security Mode	Explanation
Operation Mode	This mode allows basic operation of the robot (stopping, starting, etc.) for people operating the robot work on the line.
Editing Mode	This mode allows the operator to teach and edit jobs and robot settings.
Management Mode	This mode allows those authorized to set up and maintain robot system: parameters, system time and modifying user IDs.

Table 2-1: Menu & Security Mode (Sheet 1 of 4)

Main Menu	Sub Menu	Allowed Security Mode	
		DISPLAY	EDIT
JOB	JOB	Operation	Edit
	SELECT JOB	Operation	Operation
	CREATE NEW JOB ¹⁾	Edit	Edit
	MASTER JOB	Operation	Edit
	JOB CAPACITY	Operation	-
	CYCLE	Operation	Operation

Table 2-1: Menu & Security Mode (Sheet 2 of 4)

Main Menu	Sub Menu	Allowed Security Mode	
		DISPLAY	EDIT
VARIABLE	BYTE	Operation	Edit
	INTEGER	Operation	Edit
	DOUBLE	Operation	Edit
	REAL	Operation	Edit
	STRING	Operation	Edit
	POSITION (ROBOT)	Operation	Edit
	POSITION (BASE)	Operation	Edit
	POSITION (ST)	Operation	Edit
	LOCAL VARIABLE ¹⁾	Operation	-
IN/OUT	EXTERNAL INPUT	Operation	Edit
	EXTERNAL OUTPUT	Operation	Edit
	UNIVERSAL INPUT	Operation	Operation
	UNIVERSAL OUTPUT	Operation	Operation
	SPECIFIC INPUT	Operation	-
	SPECIFIC OUTPUT	Operation	-
	RIN	Operation	-
	CPRIN	Operation	-
	REGISTER	Operation	Management
	AUXILIARY RELAY	Operation	-
	CONTROL INPUT	Operation	-
	PSEUDO INPUT SIG	Operation	Management
	NETWORK INPUT	Operation	-
	NETWORK OUTPUT	Operation	-
	ANALOG OUTPUT	Operation	-
	SV POWER STATUS	Operation	-
	TERMIMAL	Operation	-
	LADDER PROGRAM	Management	Management
	I/O ALARM	Management	Management
	I/O MESSAGE	Management	Management

1) Displayed in the teach mode only.

Table 2-1: Menu & Security Mode (Sheet 3 of 4)

Main Menu	Sub Menu	Allowed Security Mode	
		DISPLAY	EDIT
ROBOT	CURRENT POSITION	Operation	-
	COMMAND POSITION	Operation	-
	SERVO MONITOR	Management	-
	WORK HOME POS	Operation	Edit
	SECOND HOME POS	Operation	Edit
	DROP AMOUNT	Management	Management
	POWER ON/OFF POS	Operation	-
	TOOL	Edit	Edit
	INTERFERENCE	Management	Management
	SHOCK SENS LEVEL	Operation	Edit
	USER COORDINATE	Edit	Edit
	HOME POSITION	Management	Management
	MANIPULATOR TYPE	Management	-
	ANALOG MONITOR	Management	Management
	OVERRUN&S-SENSOR ¹⁾	Edit	Edit
	LIMIT RELEASE ¹⁾	Edit	Edit
	ARM CONTROL ¹⁾	Management	Management
	SHIFT VALUE	Operation	-
	HAND VIBRATION CONTROL	Operation	Management
SYSTEM INFO	VERSION	Operation	-
	MONITORING TIME	Operation	Management
	ALARM HISTORY	Operation	Management
	I/O MSG HISTORY	Operation	Management
	NETWORK SERVICE	Management	-
	USER DEFINITION MENU	Operation	Operation
	SECURITY	Operation	Operation
FD/CF	LOAD	Edit	-
	SAVE	Operation	-
	VERIFY	Operation	-
	DELETE	Operation	-
	DEVICE	Operation	Operation
	FOLDER	Edit	Management

1) Displayed in the teach mode only.

Table 2-1: Menu & Security Mode (Sheet 4 of 4)

Main Menu	Sub Menu	Allowed Security Mode	
		DISPLAY	EDIT
PARAMETER	S1CxG	Management	Management
	S2C	Management	Management
	S3C	Management	Management
	S4C	Management	Management
	A1P	Management	Management
	A2P	Management	Management
	RS	Management	Management
	S1E	Management	Management
	S2E	Management	Management
	S3E	Management	Management
	S4E	Management	Management
	S5E	Management	Management
	S6E	Management	Management
	S7E	Management	Management
	S8E	Management	Management
	SETUP	TEACHING COND.	Edit
OPERATE COND.		Management	Management
OPERATE ENABLE		Management	Management
FUNCTION ENABLE		Management	Management
JOG COND.		Management	Management
PLAYBACK COND.		Management	Management
FUNCTION COND.		Management	Management
DISPLAYING COLOR COND.		Management	Management
DATE/TIME		Management	Management
GRP COMBINATION		Management	Management
RESERVE JOB NAME		Edit	Edit
USER ID		Edit	Edit
SET SPEED		Management	Management
KEY ALLOCATION		Management	Management
JOG KEY ALLOC.		Edit	Management
RES. START (CNCT)		Management	Management
AUTO BACK SET		Management	Management
WRONG DATA LOG		Edit	Management
ENERGY SAVING FUNCTION		Edit	Management
ENCODER MAINTENANCE		Edit	Management
DISPLAY SETUP	CHANGE FONT	Operation	Operation
	CHANGE BUTTON	Operation	Operation
	INITIALIZE LAYOUT	Operation	Operation
	CHANGE WINDOW PATTERN	Operation	Operation
GENERAL	GENERAL DIAG.	Operation	Edit

2.1.1.1 Changing the Security Mode

1. Select {SYSTEM INFO} under the main menu.
 - The sub menu appears.

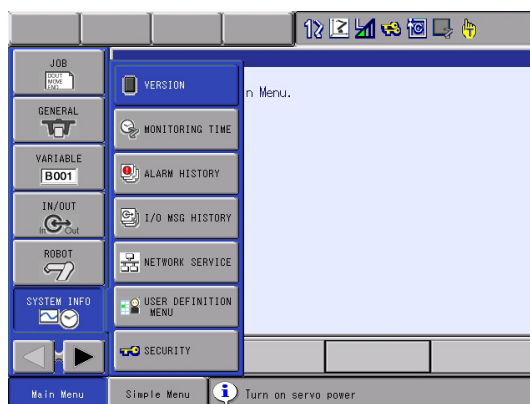

2. Select {SECURITY}.
 - The selection window of security mode appears.

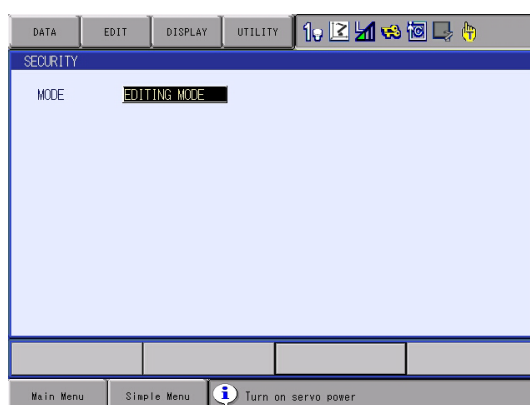

3. Press [SELECT] and select "SECURITY MODE".



2 Security System

2.1 Protection Through Security Mode Settings

4. Input the user ID.
 - The user ID input window appears.

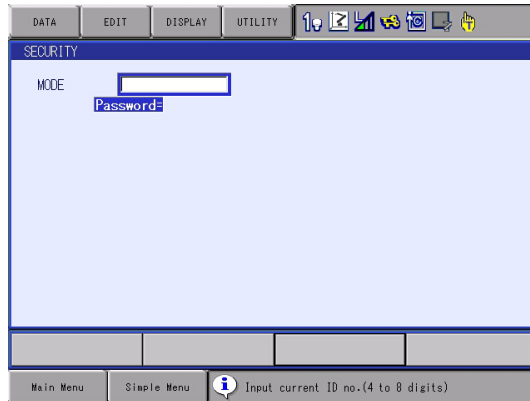

At the factory, the following below user ID number is preset.

- Editing Mode:[00000000]
- Management Mode:[99999999]

5. Press [ENTER].
 - The input user ID is compared with the user ID of the selected security mode. When the correct user ID is entered, the security mode is changed.

2.1.2 User ID

User ID is requested when Editing Mode or Management Mode is operated.

User ID must be between 4 characters and 8, and they must be numbers and symbols. ("0 to 9", "-", and ".")

2.1.2.1 Changing a User ID

In order to change the user ID, the FS100 must be in Editing Mode or Management Mode. Higher security modes can make changes the user ID of to lower security modes.

1. Select {SETUP} under the main menu.
 - The sub menu appears.

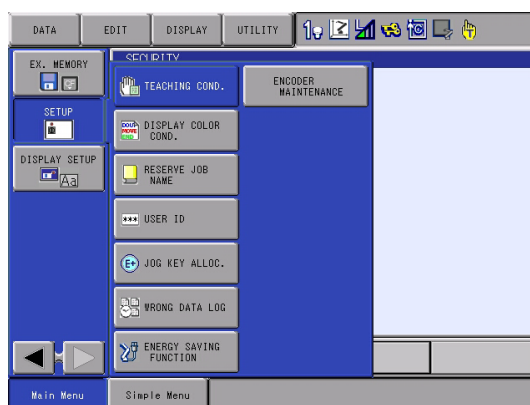

2. Select {USER ID}.
 - The USER ID window appears.

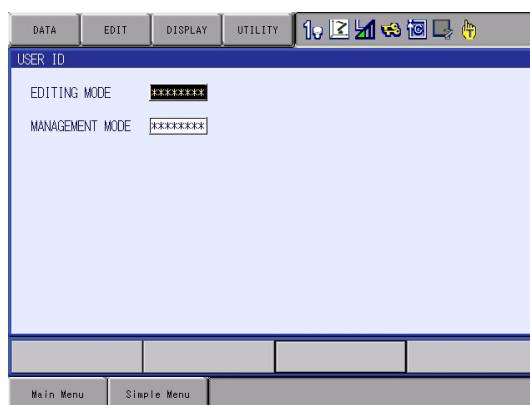

3. Select the desired ID.

- The character input line appears, and the message "Input current ID no. (4 to 8 digits)" is shown.

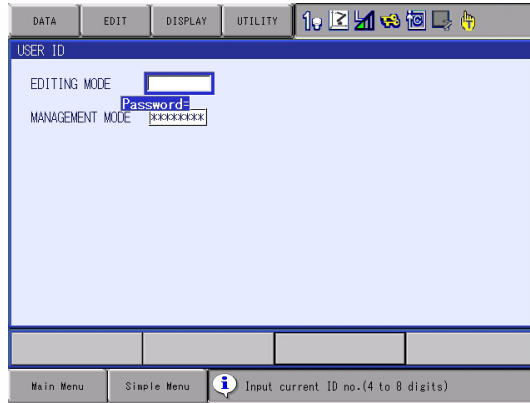

4. Input current ID and press [ENTER].

- When the correct user ID is entered, a new ID is requested to be input. "Input new ID no.(4 to 8 digits)" appears.

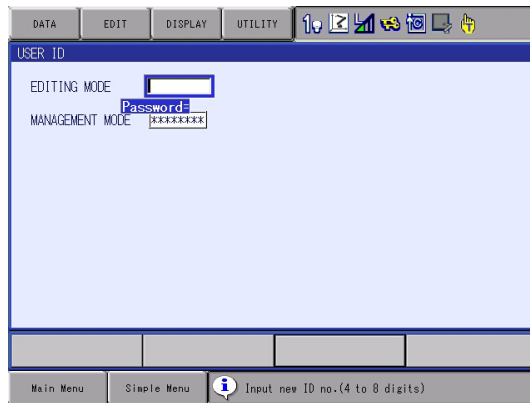

5. Input new ID and press [ENTER].

- User ID is changed.

3 Maintenance and Inspections

Operator's manual for daily inspection and parts replacement are explained in this section. Be sure to read and understand this instruction before operating the FS100.

To ensure correct and safe operation, carefully read the FS100 INSTRUCTIONS (159644-1CD).



WARNING

- Maintenance and inspections should be carried out by the qualified worker.

Failure to observe this caution may result in electric shock or injury.

3.1 Daily Inspections



WARNING

- Do not touch the cooling fan or other equipment while the power is turned ON.

Failure to observe this caution may result in electric shock or injury.

Carry out the following inspections.

Inspection Equipment	Inspection Item	Method	Inspection Interval	Comments
FS100 Controller exterior	Check for damages and cracks	Check visually	As required	Check for damages and loose connectors
Power supply cable	Check for damages or connections.	Check visually	As required	Check for damages and loose connectors
Manipulator cable (between the FS100 and the manipulator)	Check for damages or connections.	Check visually	As required	Check for damages and loose connectors
Cover mounting screws	Check for defect or loose of the screws	Use screw driver	As required	Tighten loose screws
Cooling fan	Check the operation	Check visually	As required	When the power is turned ON
Emergency stop button ¹⁾ (programming pendant)	Check the operation	By activating the button	Before the manipulator operation	When the SERVO is turned ON
Enable switch (programming pendant)	Check the operation	By activating the switch	Before the manipulator operation	During the teach mode
Battery (for the system)	Message indication Check LED lights	Check visually	As required	Before blocking the power supply

¹ Be sure to confirm that the SERVO can be turned OFF by pressing the external emergency button when the programming pendant is not used.

The external emergency button is prepared by the user.

3.2 Cooling Fan Inspections

Inspect the cooling fans as required. A defective fan can cause the FS100 to malfunction because of excessive high temperatures inside.

The interior circulation fan and cooling fan normally operate while the power is turned ON. Check if the fans are operating correctly by visual inspection and by feeling air moving into the air inlet and from the outlet.

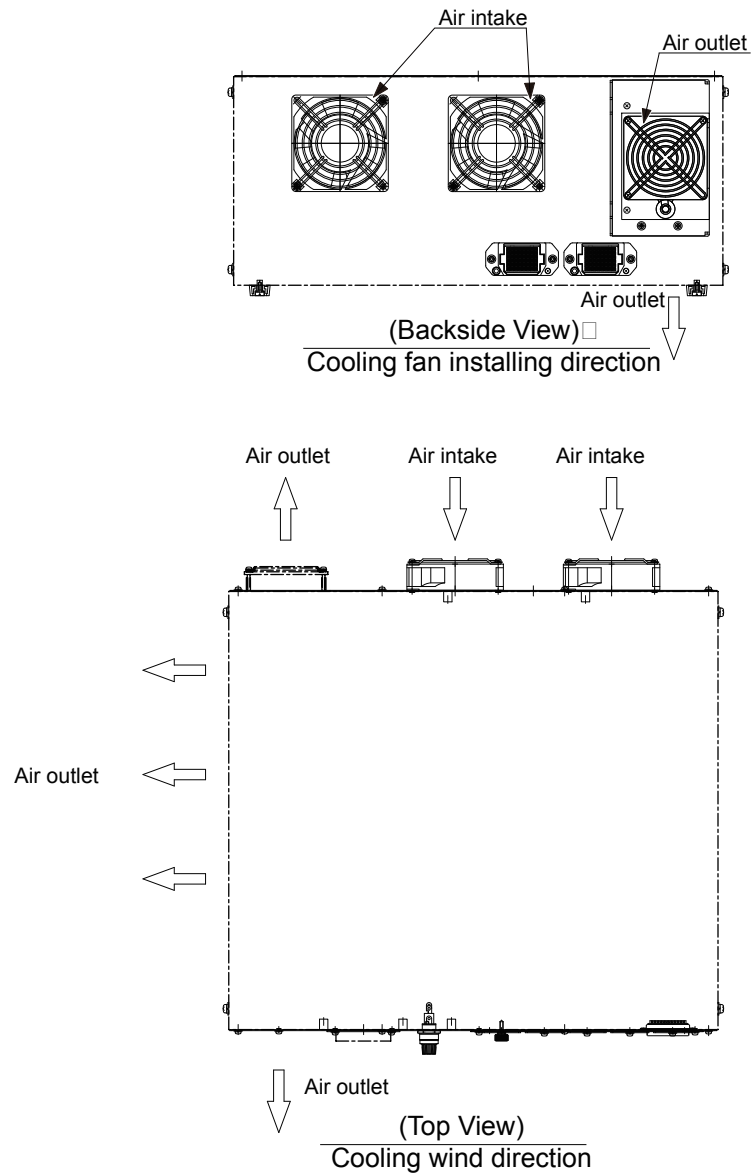

3.3 Emergency Stop Button Inspections

The emergency stop button is located on the programming pendant. Before operating the manipulator, confirm that the SERVO power is ON/OFF by pressing the emergency stop button after the SERVO is ON.

- Be sure to confirm that the SERVO can be turned OFF by pressing the external emergency button when the programming pendant is not used.
The external emergency button is prepared by the user.

3.4 Enable Switch Inspections

The programming pendant is equipped with a three-position enable switch. Perform the following operations to confirm that the enable switch is firmly operated.

- (1) Set the Mode key on the programming pendant to "TEACH".

Mode key with a switch

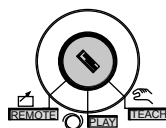

- (2) Press [SERVO ON READY] on the programming pendant. Then [SERVO ON] lamp blinks.



- (3) When the enable switch is grasped lightly, the servo power is turned ON.
When the enable switch is grasped firmly or released, the servo power is turned OFF.



If the [SERVO ON] lamp does not blink in previous operation (2), check the following:

- The emergency stop button on the programming pendant is pressed.
- The emergency stop signal is externally input.

If the [SERVO ON] lamp does not blink in previous operation (3), check the following:

- If a major alarm is occurring.

3.5 Battery Inspections

The FS100 has a battery that backs up the important program files for user data in the CMOS memory.
A battery alarm is indicated when a battery is weakened to be replaced. Also, a message "Memory battery weak" appears on the programming pendant display.
Refer to section 5.3 "Battery Replacement" on page 5-4 for the battery replacement.

When the programming pendant is not used, be sure to confirm, from the LED audit window on the FS100 front door, that the battery alarm LED of the CPU unit (CPU-201R) is not lit up.
Also, the battery alarm status can be confirmed by "battery alarm" of a system input.

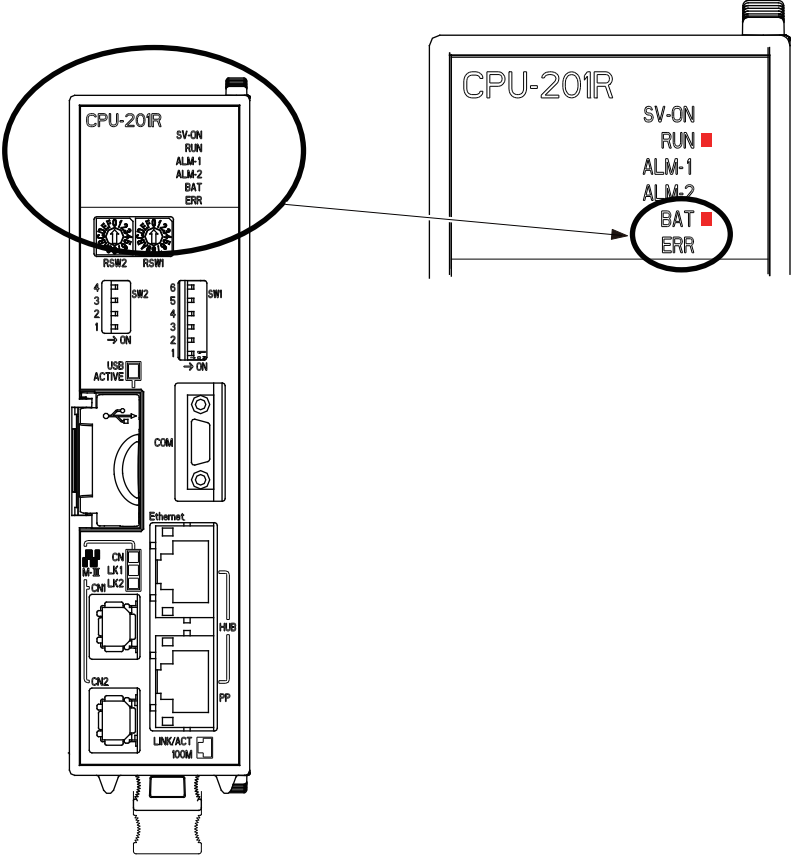

4 Preparation before Replacing Parts



WARNING

- Before operating the manipulator, check that servo power is turned OFF when the emergency stop button on the programming pendant is pressed.

When the servo power is turned OFF, the SERVO ON LED on the programming pendant is turned OFF.

Injury or damage to machinery may result if the emergency stop circuit cannot stop the manipulator during an emergency. The manipulator should not be used if the emergency stop button does not function.

- In the case of not using the programming pendant, be sure to supply the emergency stop button on the equipment. Then before operating the manipulator, check to be sure that the servo power is turned OFF by pressing the emergency stop button. Connect the external emergency stop button to the 5-6 pin and 16-17 pin of the robot system signal connector (CN2).
- Upon shipment of the FS100, this signal is connected by a jumper cable in the dummy connector. To use the signal, make sure to supply a new connector, and then input it.

If the signal is input with the jumper cable connected, it does not function, which may result in personal injury or equipment damage.

- Observe the following precautions when performing teaching operations within the manipulator's operating range:
 - Be sure to use a lockout device to the safeguarding when going inside. Also, display the sign that the operation is being performed inside the safeguarding and make sure no one closes the safeguarding.
 - View the manipulator from the front whenever possible.
 - Always follow the predetermined operating procedure.
 - Ensure that you have a safe place to retreat in case of emergency.

Improper or unintended manipulator operation may result in injury.

- Confirm that no person is present in the manipulator's operating range and that you are in a safe location before:
 - Turning ON the power for the FS100.
 - Moving the manipulator with the programming pendant.

Injury may result if anyone enters the manipulator's operating range during operation. Always press an emergency stop button immediately if there are problems.

The emergency stop button is located on the programming pendant.



CAUTION

- Perform the following inspection procedures prior to conducting manipulator teaching. If problems are found, replace them immediately, and be sure that all other necessary processing has been performed.
 - Check for problems in manipulator movement.
 - Check for damage to the insulation and sheathing of external wires.
- Return the programming pendant to a safe place after use.

If the programming pendant is inadvertently left on the manipulator, on a fixture, or on the floor, the manipulator or a tool may collide with the programming pendant during manipulator movement, which may result in personal injury or equipment damage.

The following flowchart shows the operations for replacing parts.

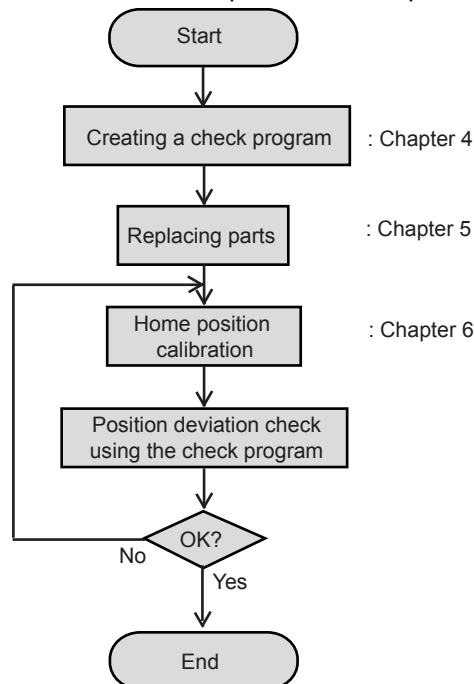

This chapter describes how to create a check program as a preparation for replacing parts. The check program is a program to check the position deviation. If positions are deviated, home position calibration is required. For the calibration, this program data is used to correct the home position data. In the following cases particularly, the home position calibration using the check program is needed. Be sure to create a check program referring to *section 4.1 "Creating a Check Program" on page 4-3*.

- Change in the combination of the manipulator and FS100
- Replacement of the motor or absolute encoder
- Clearing stored memory (by replacement of main CPU board, weak battery, etc.)
- Home position deviation caused by hitting the manipulator against a workpiece, etc.

4.1 Creating a Check Program

To check position deviation whenever necessary, create a program in which a check point is taught (the job for the check point). In the job for the check point, teach two points; one as a check point and the other as the point to approach the check point. This program checks for any deviation between the tool tip position and the check point.

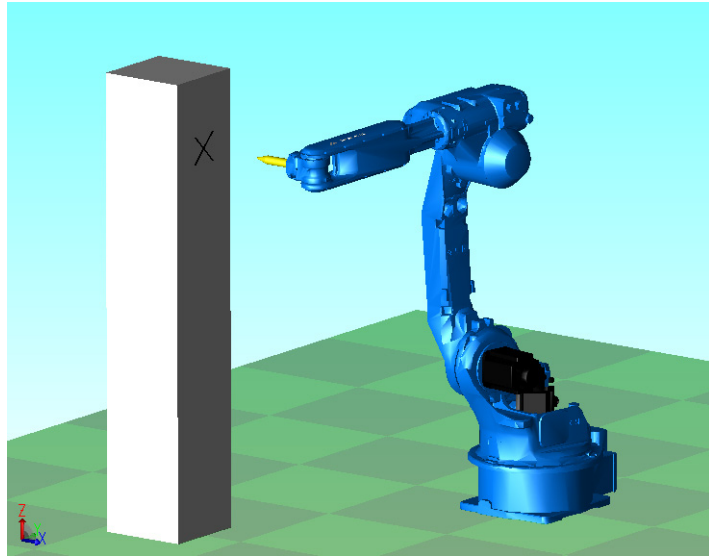
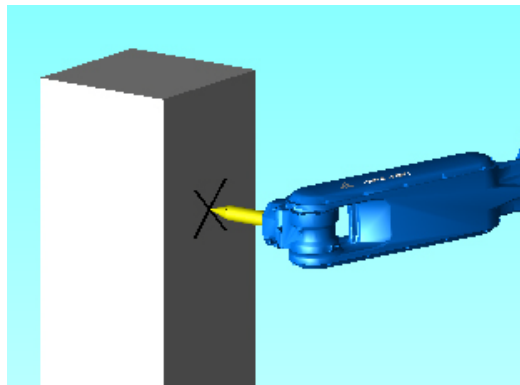

Fig. 4-1: <Enlarged View>



5 Replacing Parts



WARNING

- To prevent anyone inadvertently turning ON the power supply (including a pressurized air), put up a warning sign such as "DO NOT TURN ON THE POWER" before the maintenance, inspection, or wiring operation.



WARNING

- Maintenance and inspections should be carried out by the qualified worker.

Failure to observe this caution may result in electric shock or injury.

5.1 Fuse Replacement

Following fuses¹⁾ are mounted in the FS100.

Fuse name	Where to mount	Type	Manufacturer
I/O power supply fuse (F1: left side of the following figure)	Front side of the FS100	0312.600, 250V, 0.6A 6.3 dia. x 32 mm, fast-blow type	Littell Fuse Ltd.
Fuse for regenerative resistor fan protection ²⁾ (F2: right side of the following figure)	Front side of the FS100	250V, 1A 5 dia. x 20 mm	Littell Fuse Ltd.

1 A fuse is delivered with the FS100 before shipment for replacement.

2 Fuse for regenerative resistor fan protection is mounted on the FS100 for HP20F only.

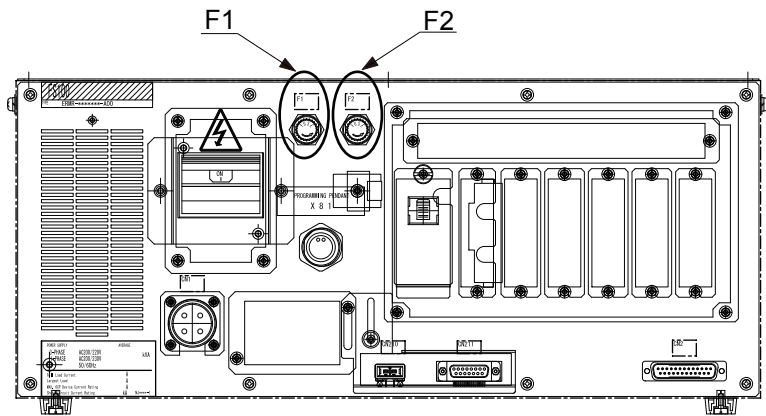

Locations of the fuse

If the fuse seems to be blown, check its conduction. If it is blown, replace it with the same type of fuse (supplied).



If the fuse seems to be blown, be sure to investigate its cause, or blown again after the replacement.

5.2 Interior Circulation Fan Replacement

Only interior cooling fan EV2 and EV3 can be replaced.



Turn OFF the power before replacing the fan.

■ Replacement Procedures

1. Disconnect plug codes connected to the fan.
(Remove the ground wirings screwed to the fan, too)
2. Remove the screws (3 places) fixing the fan and the fan guard.
3. Uninstall the fan from the FS100.
4. Install the new fan to the FS100.
(When installing the fan, be carefully to its installing direction so that the air is drawn inside the FS100.)
5. Tighten the screws (3 places) to fix the fan and the fan guard.
6. Connect all the disconnected plug codes and the ground wirings.
(Connect the plug code securely so that there is no space between the plug code and the fan. Also, connect the ground wirings firmly.)

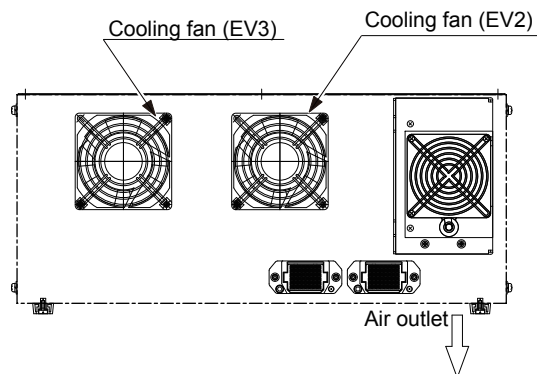

Interior Circulation Fan for Replacement

5.3 Battery Replacement

The battery must be replaced as soon as the battery alarm occurred. Please be sure to replace it within 1 hour after the power is turned OFF.

(When the programming pendant is used, a message to ask battery replacement appears on its window.

Also, the timing can be confirmed by the lighting-up of the battery alarm LED on the CPU unit (CPU-201R) or the battery alarm of the specified output.)



WARNING

- To perform this operation, it is required to open the top plate of the FS100 while the power is turned ON.

Do NOT open the plate to perform the operation within five minutes after turning OFF the FS100 power supply and primary power source.

- Do NOT touch units or terminal parts within five minutes after turning OFF the FS100 power supply.

Failure to observe this warning may result in electric shocks.

- Close the top plate as soon as the maintenance work such as the inspection or maintenance, etc. is completed.

Failure to observe this warning may result in electric shocks.



WARNING

- To prevent anyone inadvertently turning ON the power supply during maintenance operation, put up a warning sign such as "DO NOT TURN ON THE POWER" at the primary power supply (knife switch, wiring circuit breaker, etc.) .

Failure to observe this warning may result in electric shocks or injury.

■ Replacement Procedure

1. Uninstall the top plate and loosen the strap which is fixing the battery.

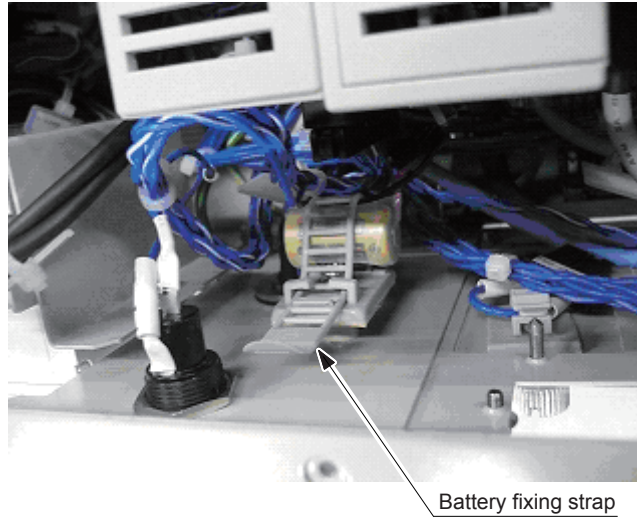

2. Disconnect the connector from the battery extension lead wire and remove the battery.

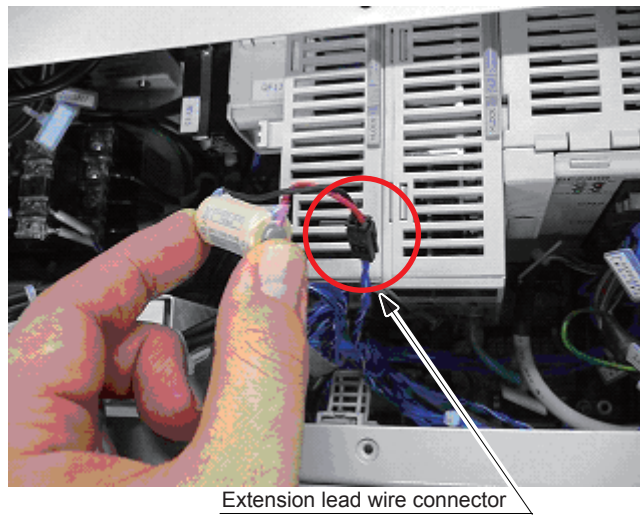

3. Connect the new battery to the battery extension lead wire.

5 Replacing Parts
5.3 Battery Replacement

4. Fix the battery with the strap.
Fasten the strap till the third hole of it.
When fixing the battery, put the black lead wire toward inner side of the FS100.

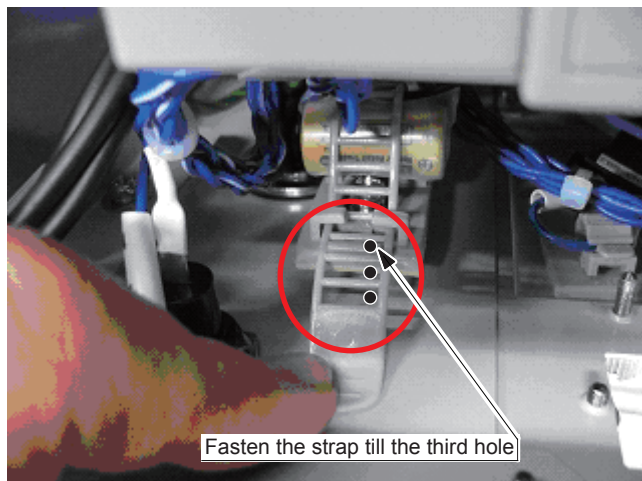
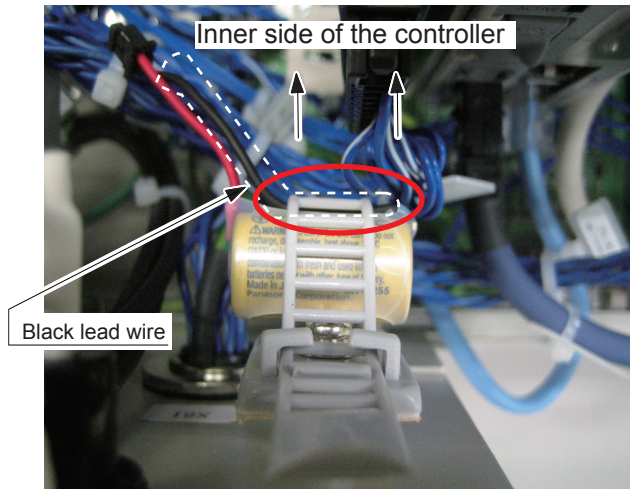

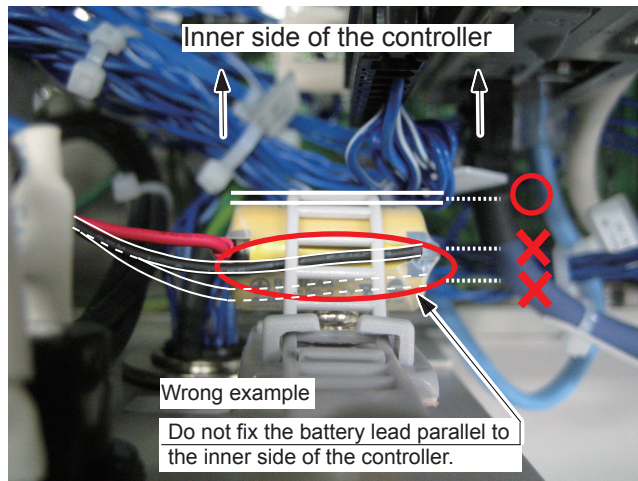

Fix the battery lead wire to the inner side of the controller. □
 The battery might fall off due to the vibration, etc., □
 if the lead wire is fixed parallel to the controller.



Although the CMOS memory is backed up by super capacitor, the battery must be replaced as soon as the message "Memory battery weak" appears.

The job data and other data may be lost if the message "Memory battery weak" appears and the breaker is turned OFF for more than 1 hours.

6 Recommended Spare Parts

6.1 List of Accessories

Accessories of FS100 are as follows.

No.	Name	Type	Manufacturer	Qty.	Qty. per unit
1	Power supply connector	CE05-6A18-10SD-D-BSS	DDK	1	1
	Waterproof cable clamp	CE3057-10A-1-D	DDK	1	1
2	Dummy connector for safety signal short circuit	HB1370101-1	Yaskawa	1	1
3	I/O power supply protection fuse	0312.600MXP	Littell	1	1

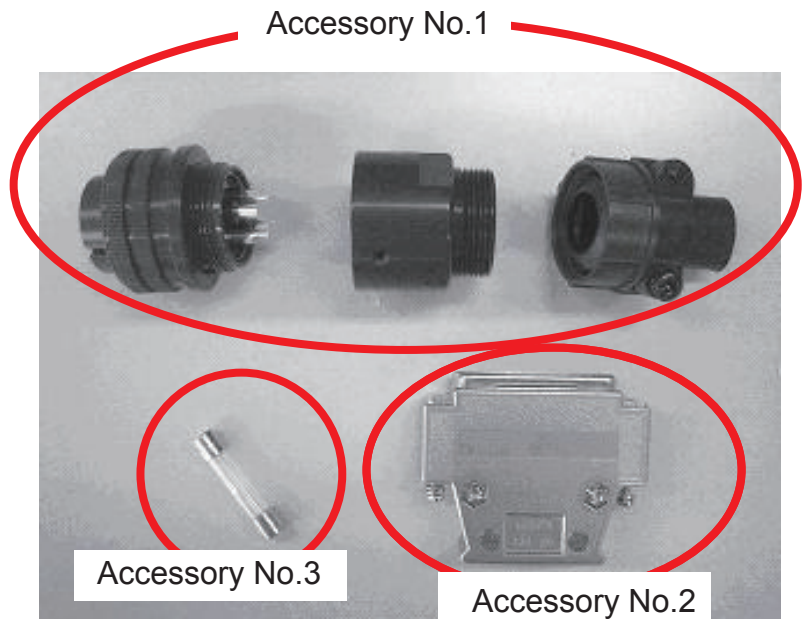

6.2 Recommended Spare Parts

The spare parts are ranked as follows.



CAUTION

- It is recommended to use the parts and components in the following table as spare parts for the FS100.

Product performance cannot be guaranteed when using spare parts from any company other than Yaskawa.

- Rank A: Expendable and frequently replaced parts.
- Rank B: Parts for which replacement may be necessary as a result of frequent operation.
- Rank C: Drive unit.

Table 6-1: Spare Parts for the FS100

Rank	Parts No.	Name	Type	Manufacturer	Qty.	Qty. per unit	Remark
A	1	Battery	BR-1/2AA 3.0V	Panasonic	1	1	When the battery alarm occurred
A	2	I/O power supply protection fuse	0312.600MXP	Littell	1	1	
C	3	Cooling fan (EV2, EV3)	3610PS-22T-B30-B00 or 09225PB-B2L-EA-02	MINEBEA	2	2	After 6 years or 36000h, whichever is earlier.

7 Operations After Replacing Parts



WARNING

- Before operating the manipulator, check that servo power is turned OFF when the emergency stop button on the programming pendant is pressed.

Injury or damage to machinery may result if the emergency stop circuit cannot stop the manipulator during an emergency. The manipulator should not be used if the emergency stop button does not function.

- In the case of not using the programming pendant, be sure to supply the emergency stop button on the equipment. Then before operating the manipulator, check to be sure that the servo power is turned OFF by pressing the emergency stop button. Connect the external emergency stop button to the 5-6 pin and 16-17 pin of the robot system signal connector (CN2).
- Upon shipment of the FS100, this signal is connected by a jumper cable in the dummy connector. To use the signal, make sure to supply a new connector, and then input it.

If the signal is input with the jumper cable connected, it does not function, which may result in personal injury or equipment damage.

- Observe the following precautions when performing teaching operations within the manipulator's operating range:
 - Be sure to use a lockout device to the safeguarding when going inside. Also, display the sign that the operation is being performed inside the safeguarding and make sure no one closes the safeguarding.
 - View the manipulator from the front whenever possible.
 - Always follow the predetermined operating procedure.
 - Ensure that you have a safe place to retreat in case of emergency.

Improper or unintended manipulator operation may result in injury.

- Confirm that no person is present in the manipulator's operating range and that you are in a safe location before:
 - Turning ON the power for the FS100.
 - Moving the manipulator with the programming pendant.

Injury may result if anyone enters the working envelope of the manipulator during operation. Always press an emergency stop button immediately if there are problems.

Emergency stop buttons is located at the upper right of the programming pendant.



CAUTION

- Perform the following inspection procedures prior to conducting manipulator teaching. If problems are found, repair them immediately, and be sure that all other necessary processing has been performed.
 - Check for problems in manipulator movement.
 - Check for damage to the insulation and sheathing of external wires.
- Return the programming pendant to a safe place after use.

If the programming pendant is inadvertently left on the manipulator, on a fixture, or on the floor, the manipulator or a tool may collide with the programming pendant during manipulator movement, which may result in personal injury or equipment damage.

7.1 Home Position Calibration

7.1.1 Home Position Calibration

Teaching and playback are not possible before home position calibration is complete.



In a system with two or more manipulators, the home position of all the manipulators must be calibrated before starting teaching or playback.

Set the security mode to the management mode to perform home position calibration.

Home position calibration is an operation in which the home position and absolute encoder position coincide. Although this operation is performed prior to shipment at the factory, the following cases require this operation to be performed again.

- Change in the combination of the manipulator and FS100
- Replacement of the motor or absolute encoder
- Clearing stored memory (by replacement of main CPU board, weak battery, etc.)
- Home position deviation caused by hitting the manipulator against a workpiece, etc.

To calibrate the home position, use the axis keys to calibrate the mark for the home position on each axis so that the manipulator can take its posture for the home position. There are two operations for home position calibration:

- All the axes can be moved at the same time
- Axes can be moved individually

If the absolute data of the home position is already known, set the absolute data again after completing home position registration.

**Home Position**

The home position is the position with the pulse value "0" for each axis. See *section 7.1.3 "Manipulator Home Position" on page 7-10*.

7.1.2 Calibrating Operation

7.1.2.1 Registering All Axes at One Time

1. Select {ROBOT} under the main menu.
2. Select {HOME POSITION}.
- The HOME POSITIONING window appears.

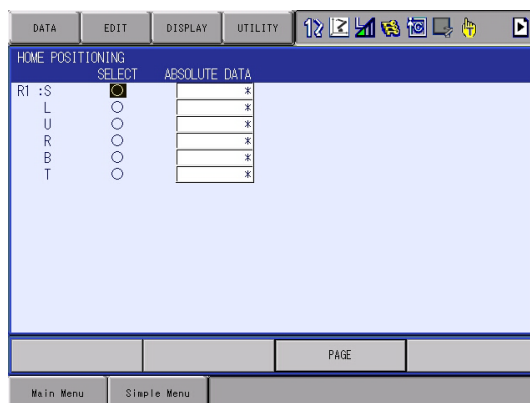

3. Select {DISPLAY} under the menu,
or select "PAGE" to display the selection window for the control group,
or press page key .
- The pull-down menu appears.

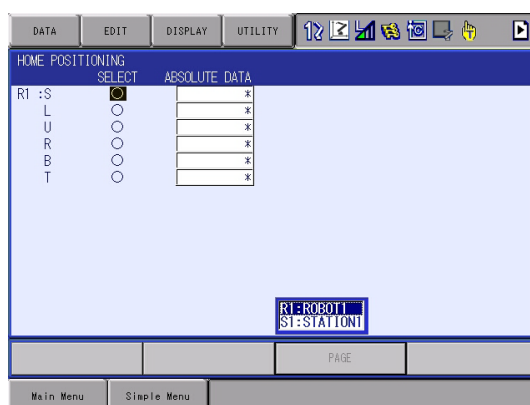
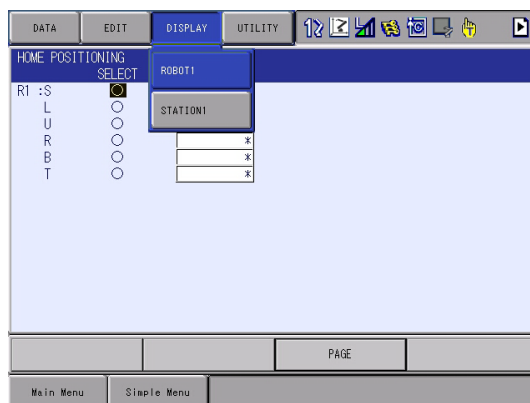

4. Select the desired control group.
5. Select {EDIT} under the menu.
 - The pull-down menu appears.

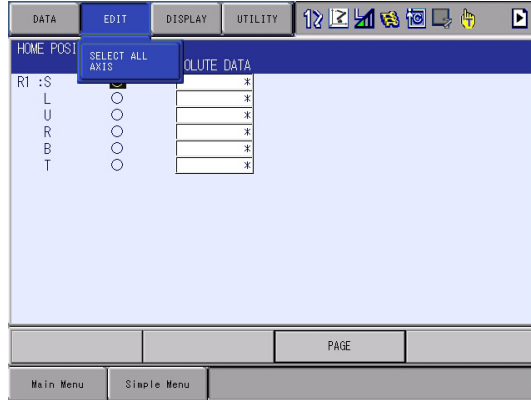

6. Select {SELECT ALL AXES}.
- The confirmation dialog box appears.

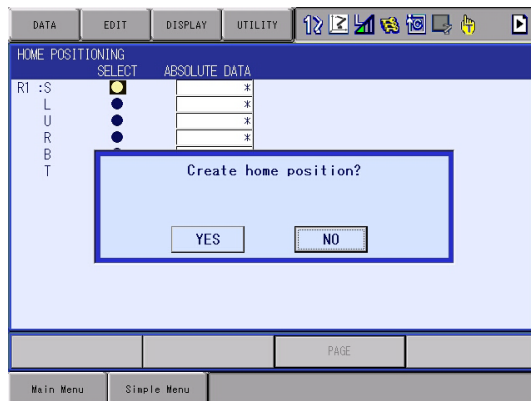

7. Select "YES".
 - Displayed position data of all axes are registered as home position.
 - When "NO" is selected, the registration will be canceled.

7.1.2.2 Registering Individual Axes

1. Select {ROBOT} under the main menu.
2. Select {HOME POSITION}.
3. Select the desired control group.
 - Perform steps 3 and 4 which have been described in *section 7.1.2.1 “Registering All Axes at One Time”* on page 7-4 to select the desired control group.
4. Select the axis to be registered.

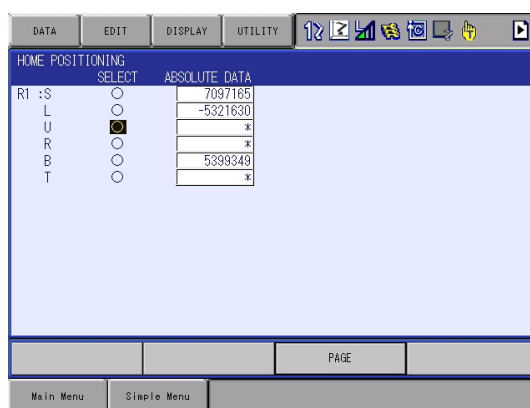

- The confirmation dialog box appears.

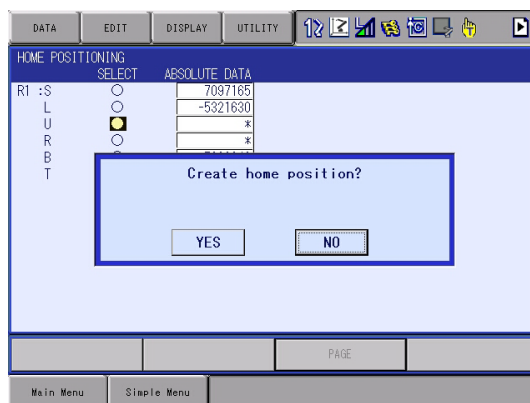

5. Select "YES".
 - Displayed position data of the axis are registered as home position. When "NO" is selected, the registration will be canceled.

7.1.2.3 Changing the Absolute Data

To change the absolute data of the axis when home position calibration is completed, perform the following:

1. Select {ROBOT} under the main menu.
2. Select {HOME POSITION}.
3. Select the desired control group.
 - Perform steps 3 and 4 which have been described in "Registering All Axes at One Time" to select the desired control group
4. Select the absolute data to be registered.
 - The number can now be entered.

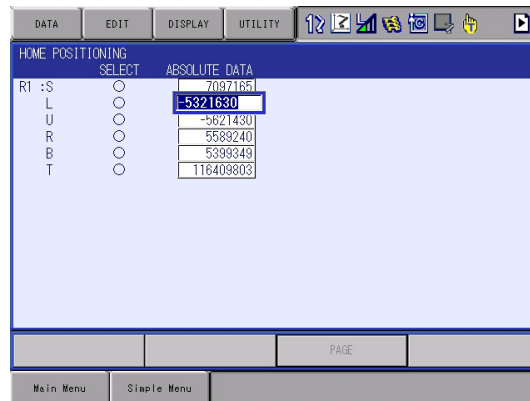

5. Enter the absolute data using the numeric keys.
6. Press [ENTER].
 - Absolute data are modified.

7.1.2.4 Clearing Absolute Data

1. Select {ROBOT} under the main menu.
2. Select {HOME POSITION}.
 - Perform steps 2, 3, and 4 which have been described in "Registering All Axes at One Time" to display the HOME POSITIONING window and select the desired control group.
3. Select {DATA} under the menu.
 - The pull-down menu appears.

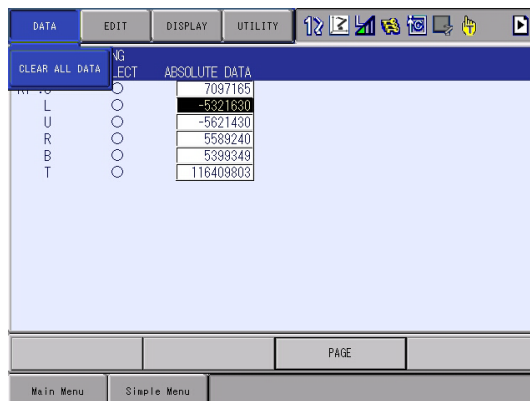

4. Select {CLEAR ALL DATA}.
 - The confirmation dialog box appears.



5. Select "YES".

- The all absolute data are cleared. When "NO" is selected, the operation will be canceled.

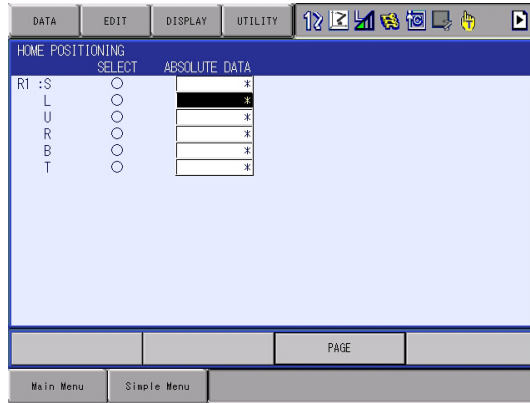

7.1.3 Manipulator Home Position

With the MOTOMAN-HP20F, the home position is as follows.

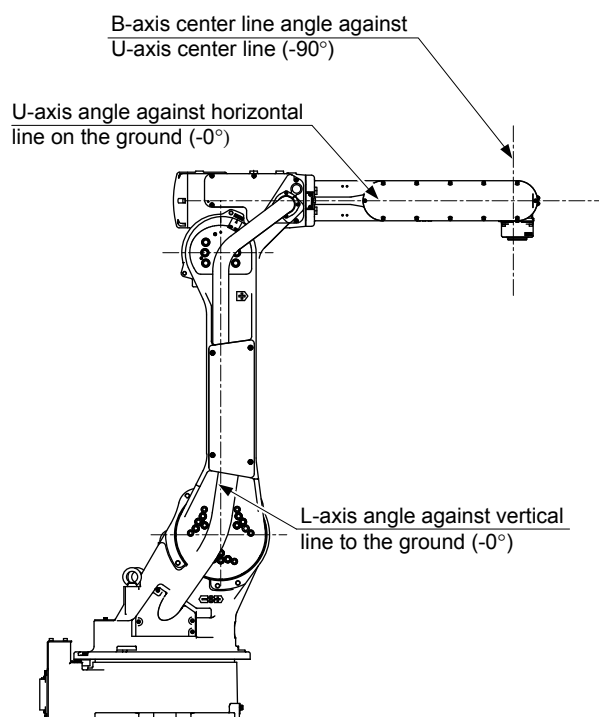

Other manipulator models have different positions. Always consult the documentation for the correct manipulator model.

7.2 Position Deviation Check Using the Check Program

Use the check program to check if positions are deviated with the following procedure.

1. Call up the check program in which the check point is taught (the job for) and operate the manipulator at low speed.

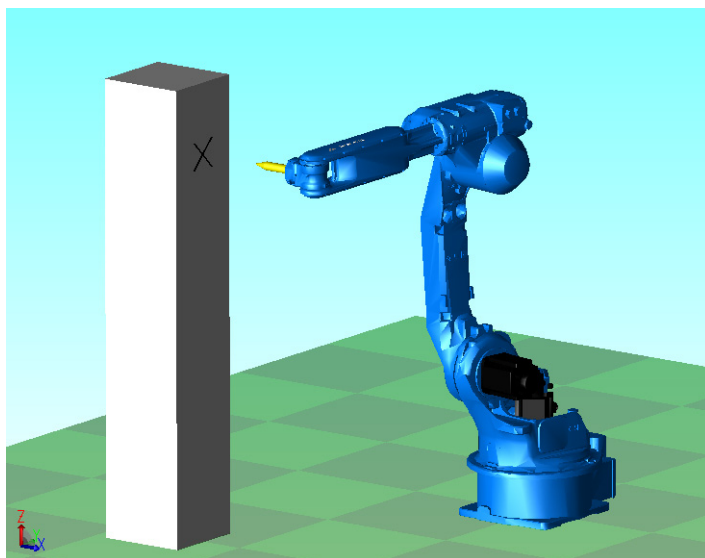

2. Check the tool tip position.
 - If it points the check point exactly as shown in the following figure, there is no deviation from the positions. Proceed to *section 7.4 “Setting the Second Home Position (Check Point)”* on page 7-14.
 - If not, there is a deviation. When the motor or encoder, etc. was replaced, move the corresponding axis only, when the stored memory was cleared or the manipulator was hit against a workpiece, move all axes, to the check point by joint motion. Then, proceed to *section 7.3.3 “Home Position Data Correction”* on page 7-13.

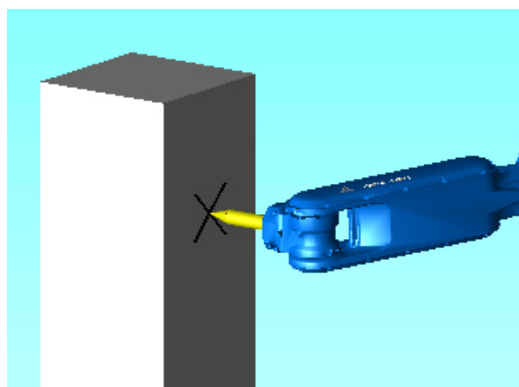

7.3 Checking of the Check Program

7.3.1 Motion of the Check Program

Call up the check program in which the check point is taught (the job for avoiding the position deviation) and operate the manipulator at low speed.

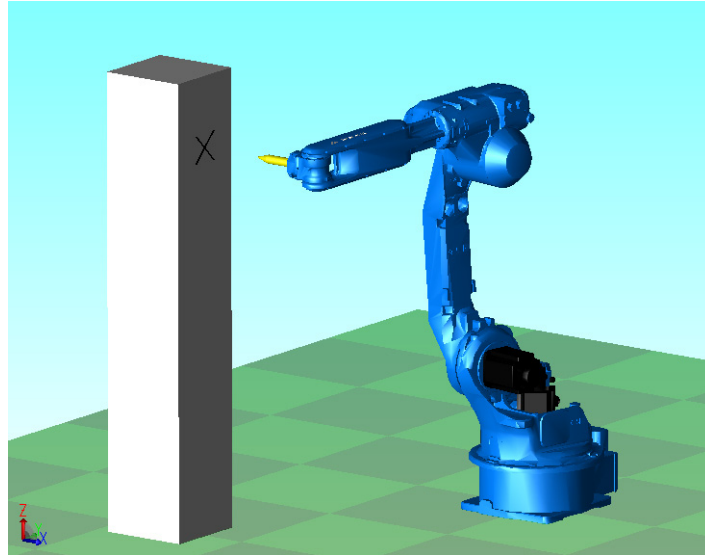

7.3.2 Checking of the Check Program

Check the deviation in to the check point. If the tool tip position is deviated, there is a deviation.

When the motor or encoder, etc. was replaced, move the corresponding axis only, when the stored memory was cleared or the manipulator was hit against a workpiece, move all axes, to the check point by joint motion.

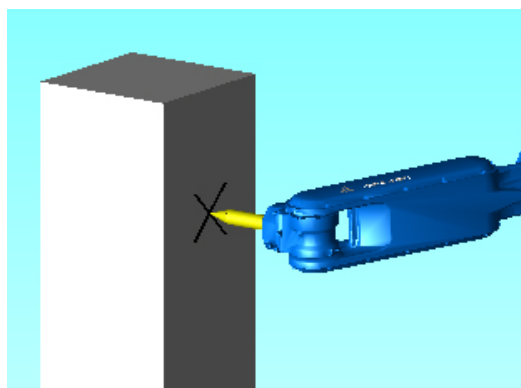

7.3.3 Home Position Data Correction

When there is a deviation from the positions, correct the home position data with the following procedure.

1. Check the values of the following pulses.
 - If there is no deviation, the following two values coincide. Then, proceed to *section 7.4 “Setting the Second Home Position (Check Point)” on page 7-14.*
 - If there is a deviation, execute the following procedures to correct it.
 - (1) Command position pulse of the check point which was taught in advance

Displaying the Command Position Pulse
 - I) Select {ROBOT} under the main menu.
 - II) Select {COMMAND POSITION}.
 - (2) Current position pulse where the manipulator (tool tip) was moved to the check point after performing the check program

Displaying the Current Position Pulse
 - I) Select {ROBOT} under the main menu.
 - II) Select {CURRENT POSITION}.
2. Calculate the difference between the command position pulse and the current position pulse.

The difference pulse = Command position pulse – Current position pulse
3. On the HOME POSITIONING window, add the difference pulse value to the absolute data of the axis whose motor or encoder, etc. was replaced.
4. Modify the home position data by following the procedures described in *section 7.1.2.3 “Changing the Absolute Data” on page 7-7.*
5. Confirm that the command position pulse and the current position pulse coincide.
 - The home position data have been corrected.
 - Proceed to *section 7.2 “Position Deviation Check Using the Check Program” on page 7-11.*

7.4 Setting the Second Home Position (Check Point)



WARNING

- Be aware of safety hazards when performing the position confirmation of the second home position (check point).

Abnormality of the PG system may be a cause for alarm. The manipulator may operate in an unexpected manner, and there is a risk of damage to equipment or injury to personnel.

- Before operating the manipulator, check that the SERVO ON lamp goes out when the emergency stop button on the programming pendant is pressed.

Injury or damage to machinery may result if the manipulator cannot be stopped in case of an emergency.

- In the case of not using the programming pendant, be sure to supply the emergency stop button on the equipment. Then before operating the manipulator, check to be sure that the servo power is turned OFF by pressing the emergency stop button. Connect the external emergency stop button to the 5-6 pin and 16-17 pin of the robot system signal connector (CN2).
- Upon shipment of the FS100, this signal is connected by a jumper cable in the dummy connector. To use the signal, make sure to supply a new connector, and then input it.

If the signal is input with the jumper cable connected, it does not function, which may result in personal injury or equipment damage.

- Observe the following precautions when performing teaching operations within the manipulator's operating range:
 - Be sure to use a lockout device to the safeguarding when going inside. Also, display the sign that the operation is being performed inside the safeguarding and make sure no one closes the safeguarding.
 - View the manipulator from the front whenever possible.
 - Always follow the predetermined operating procedure.
 - Ensure that you have a safe place to retreat in case of emergency.

Improper or unintended manipulator operation may result in injury.

- Prior to performing the following operations, be sure that no one is in the manipulator's operating range, and be sure that you are in a safe place when:
 - Turning ON the FS100 power.
 - Moving the manipulator with the programming pendant.

Injury may result from contact with the manipulator if persons enter the manipulator's operating range.

Always press the emergency stop button immediately if there are problems.

Emergency stop button is attached on the programming pendant.



CAUTION

- Perform the following inspection procedures prior to teaching the manipulator. If problems are found, correct them immediately, and be sure that all other necessary tasks have been performed.
 - Check for problems in manipulator movement.
 - Check for damage to the insulation and sheathing of external wires.
- Return the programming pendant to a safe place after use.

If the programming pendant is inadvertently left on the manipulator, on a fixture, or on the floor, the manipulator or a tool may collide with the programming pendant during manipulator movement, which may result in personal injury or equipment damage.

7.4.1 Purpose of Position Check Operation

If the absolute number of rotation detected at power supply ON does not match the data stored in the absolute encoder the last time the power supply was turned OFF, an alarm is issued when the FS100 power is turned ON.

There are two possible causes of this alarm:

- Error in the PG system
- The manipulator was moved after the power supply was turned OFF.

If there is an error with the PG system, the manipulator may stall when playback is started. If the absolute data allowable range error alarm has occurred, playback and test runs will not function and the position must be checked.

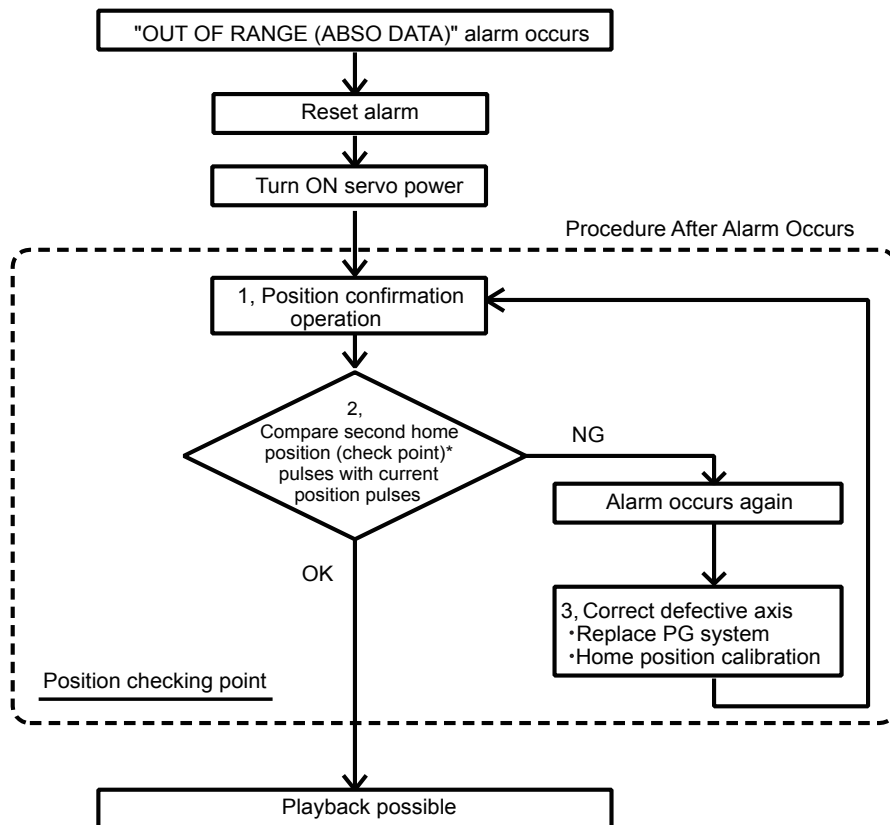

1. Position Check

After the "OUT OF RANGE (ABSO DATA)" alarm occurs, move to the second home position using the axis keys and perform the position confirmation. Playback, test runs, and FWD operation will not function unless "CONFIRM POSITION" is performed.

2. Pulse Difference Check

The pulse number at the second home position is compared with that at the current position. If the difference is within the allowable range, playback is enabled. If not, the alarm occurs again.

- The allowable range pulse is the number of pulses per rotation of the motor (PPR data).
- The initial value of the second home position is the home position (where all axes are at pulse 0). The second home position can be changed. For details, refer to *section 7.4.2 "Procedure for the Second Home Position Setting (Check Point)" on page 7-18*.

3. Alarm Occurrence

If the alarm occurs again, there may be an error in the PG system. Check the system. After adjusting the erroneous axis, calibrate the home position of the axis, then check the position again.



- Home position calibration of all the axes at the same time enables playback operations without having to check the position.
- Sometimes in a system with a manipulator that has no brake, it is possible to enable playback without position checking after the alarm occurs. However, as a rule, always perform "COMFIRM POSITION".

Under the above special conditions, the manipulator moves as follows:

After starting, the manipulator moves at low speed (1/10 of the maximum speed) to the step indicated by the cursor.

If it is stopped and restarted during this motion, the low speed setting is retained until the step at cursor is reached. Regardless of cycle setting, the manipulator stops after the cursor step is reached.

Starting the manipulator again then moves it at the programmed speed and cycle of the job.

7.4.2 Procedure for the Second Home Position Setting (Check Point)

Apart from the "home position" of the manipulator, the second home position can be set up as a check point for absolute data. Use the following steps to set the specified point.

If two or more manipulators or stations are controlled by one FS100, the second home position must be set for each manipulator or station.

1. Select {ROBOT} under the main menu.
2. Select {SECOND HOME POS}.
 - The SECOND HOME POS window appears.
The message "Available to move to and modify specified point" is shown.

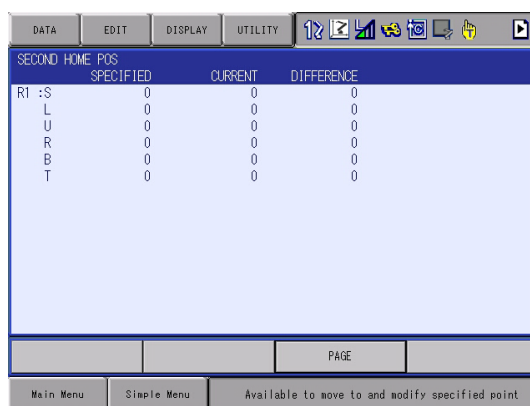

3. Press the page key , or select "PAGE" to display the selection window for the control group.
 - The group axes by which the second home position is set is selected when there are two or more group axes.

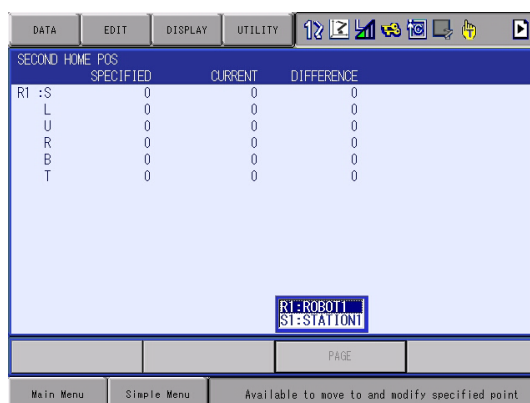

4. Press the axis keys.
 - Move the manipulator to the new second home position.
5. Press [MODIFY] and [ENTER].
 - The second home position is changed.

7.4.3 Procedure after the Alarm



WARNING

- Be aware of safety hazards when performing the position confirmation of the specified point.

Abnormality of the PG system may be cause for alarm. The manipulator may operate in an unexpected manner, and there is a risk of damage to equipment or injury to personnel.

If the "OUT OF RANGE (ABS DATA)" alarm occurs, perform the followings

- Reset the alarm
- Turn Servo power ON

and confirm the second home position. After the confirmation, if the PG system is found to be the cause of the alarm, perform the necessary operation, such as replacing the PG, etc.

The robot current position data when turning main power supply OFF and ON can be confirmed in "POWER ON/OFF POS" window.



Refer to section 8.7 "Position Data When Power is Turned ON/OFF" on page 8-23 for details on the "POWER ON/OFF POS" window.

1. Select {ROBOT} under the main menu.
2. Select {SECOND HOME POS}.
 - The SECOND HOME POS window appears.

	SPECIFIED	CURRENT	DIFFERENCE
RT :S	0	0	0
L	0	0	0
U	0	0	0
R	0	0	0
B	0	0	0
T	0	0	0

7 Operations After Replacing Parts

7.4 Setting the Second Home Position (Check Point)

3. Press the page key  .

or select "PAGE" to display the selection window for the control group.

- The group axes by which the second home position is set is selected when there are two or more group axes.



SECOND HOME POS			
	SPECIFIED	CURRENT	DIFFERENCE
R1 :S	0	0	0
L	0	0	0
U	0	0	0
R	0	0	0
B	0	0	0
T	0	0	0

R1:ROBOT1
S1:STATION1

PAGE

Main Menu Simple Menu Available to move to and modify specified point

4. Press [FWD].
- TCP moves to the second home position. The robot moving speed is set as selected manual speed.
5. Select {DATA} under the menu.
6. Select {CONFIRM POSITION}.
- The message "Home position checked" is shown. Pulse data of the second home position and current pulse data are compared. If the compared error is in allowed range, playback operation can be done. If the error is beyond the allowed range, the alarm occurs again.

8 System Diagnosis

8.1 System Version

It is possible to check the system CPU version information as follows.

1. Select {SYSTEM INFO} under the main menu.
 2. Select {VERSION}.
- The VERSION window appears.

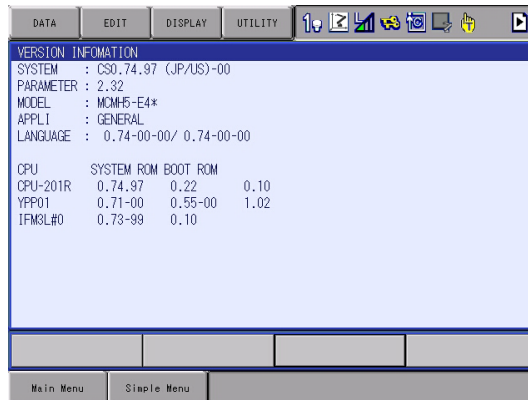

8.2 Manipulator Model

1. Select {ROBOT} under the main menu.
 2. Select {MANIPULATOR TYPE}.
- The ROBOT AXIS CONFIG window appears.

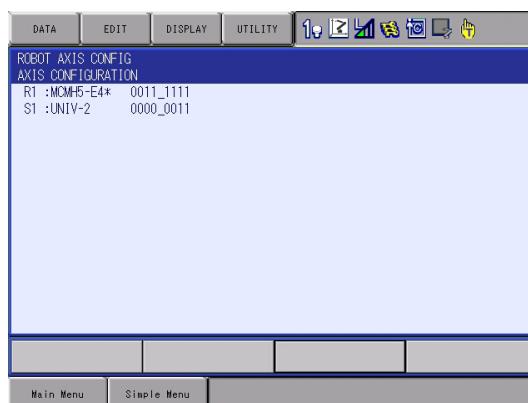

8.3 Input/Output Status

8.3.1 Universal Input

The status of input signal which is referred to by input instruction of a job can be confirmed.

8.3.1.1 Universal Input Window

1. Select {IN/OUT} under the main menu.
2. Select {UNIVERSAL INPUT}.
 - The UNIVERSAL INPUT window appears.

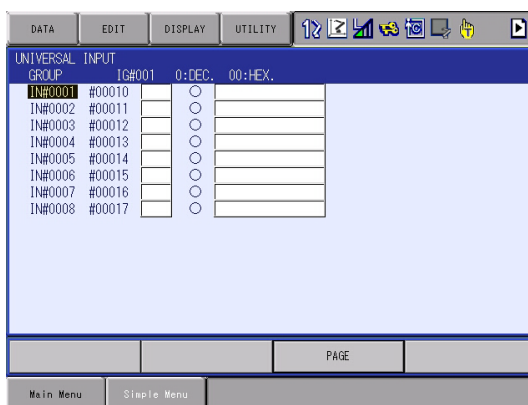

8.3.1.2 Universal Input Simple Window

1. Select {IN/OUT} under the main menu.
2. Select {UNIVERSAL INPUT}.
 - The UNIVERSAL INPUT window appears.
3. Select {SIMPLE} from the pull-down menu of {DISPLAY}.
 - The UNIVERSAL INPUT simple window appears.

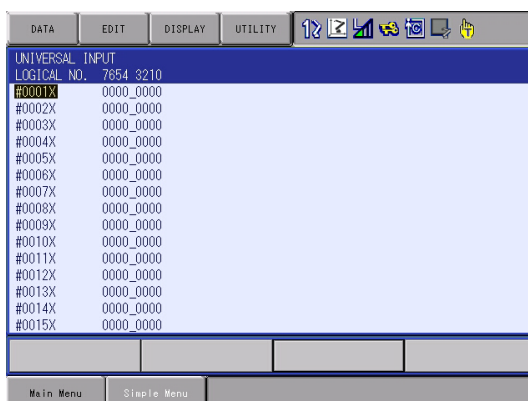

8.3.2 Universal Output

The status of the output signal set by the output instruction can be confirmed and modified.

8.3.2.1 Universal Output Window

1. Select {IN/OUT} under the main menu.
2. Select {UNIVERSAL OUTPUT}.
 - The UNIVERSAL OUTPUT window appears.

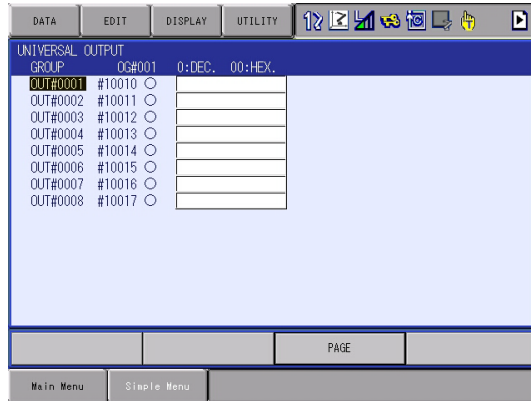

8.3.2.2 Universal Output Simple Window

1. Select {IN/OUT} under the main menu.
2. Select {UNIVERSAL OUTPUT}.
 - The UNIVERSAL OUTPUT window appears.
3. Select {SIMPLE} from the pull-down menu of {DISPLAY}.
 - The UNIVERSAL OUTPUT simple window appears.

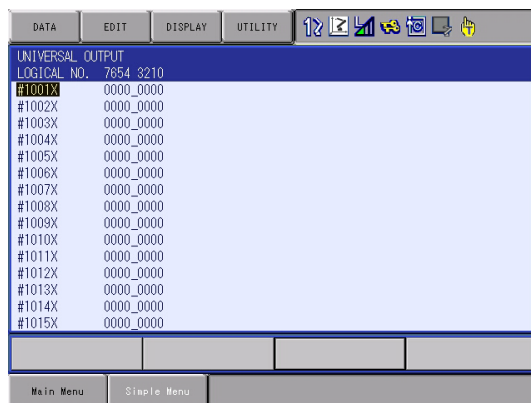

8.3.2.3 Modifying the Output Status

The status of universal output signal can be changed by the operation below.

1. Select the desired output signal number.
 - Select the status of the desired output signal, “○” or “●” in the UNIVERSAL OUTPUT window.
2. Press INTER LOCK key  + [SELECT].
 - The status is changed. (●: ON status, ○: OFF status)

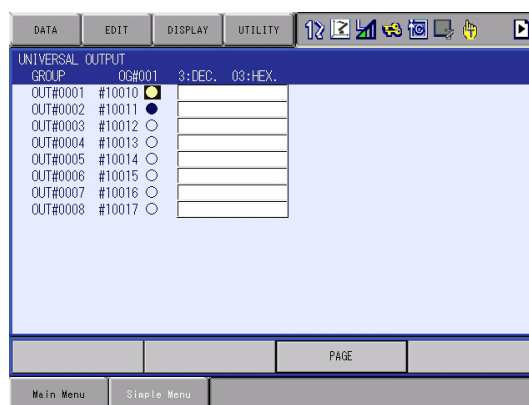

The status of universal output signal can be changed only when the mode is set to the teach mode.

8.3.3 Specific Input

8.3.3.1 Specified Input Window

1. Select {IN/OUT} under the main menu.
2. Select {SPECIFIED INPUT}.
 - The SPECIFIED INPUT window appears.



8.3.3.2 Specific Input Simple Window

1. Select {IN/OUT} under the main menu.
2. Select {SPECIFIED INPUT}.
 - The SPECIFIED INPUT window appears.
3. Select {SIMPLE} from the pull-down menu of {DISPLAY}.
 - The SPECIFIC INPUT simple window appears.

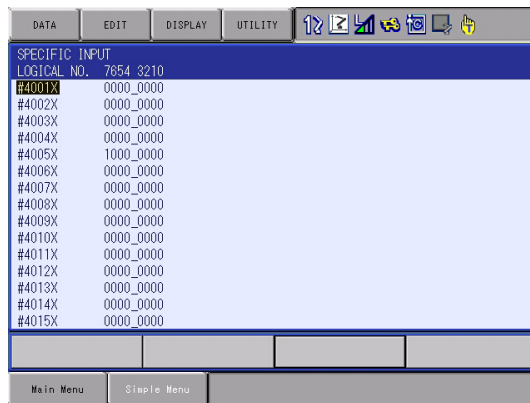

8.3.4 Specific Output

8.3.4.1 Specified Output Window

1. Select {IN/OUT} under the main menu.
2. Select {SPECIFIED OUTPUT}.
 - The SPECIFIED OUTPUT window appears.

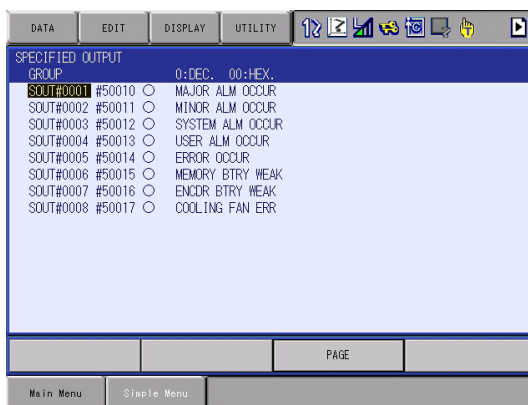

8.3.4.2 Specific Output Simple Window

1. Select {IN/OUT} under the main menu.
2. Select {SPECIFIED OUTPUT}.
 - The SPECIFIED OUTPUT window appears.
3. Select {SIMPLE} from the pull-down menu of {DISPLAY}.
 - The SPECIFIC OUTPUT simple window appears.

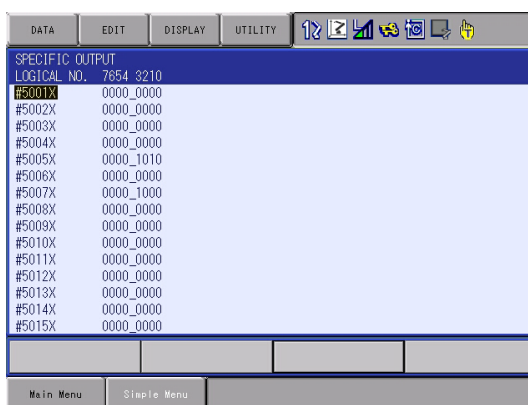

8.3.5 RIN Input

8.3.5.1 RIN Input Window

1. Select {IN/OUT} under the main menu.
2. Select {RIN}.
 - The RIN window appears.

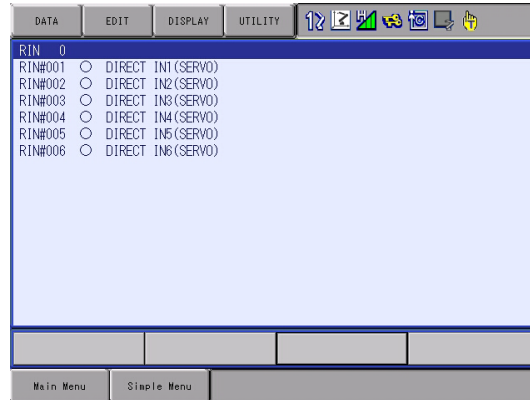

8.3.6 Signal Number Search

A search can be made for a signal number of a universal input, universal output, system input, and system output.

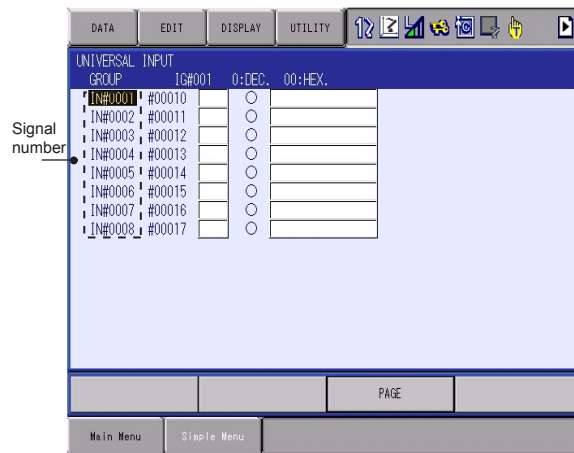

A search for the signal number can be made in the following two ways.

- Direct search on the UNIVERSAL/SPECIFIED INPUT/OUTPUT window
- Search from the menu

8.3.6.1 Direct Search on the Universal/Specified Input/Output Window

1. Move the cursor to a signal number in the UNIVERSAL/SPECIFIED INPUT/OUTPUT window, and press [SELECT].
 - Numeric values can now be entered.

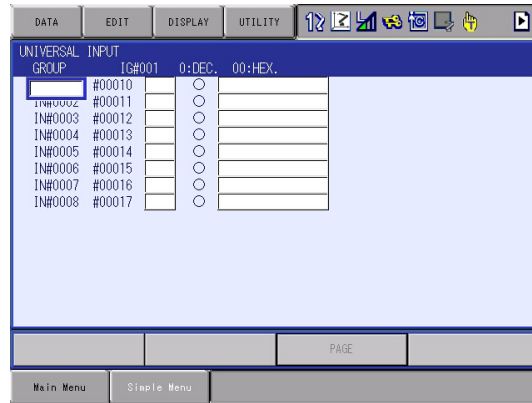

2. Enter the signal number to be searched.
 - Type the signal number in the number input line.
3. Press [ENTER] to start the search.
 - The page where the signal number exists appears.

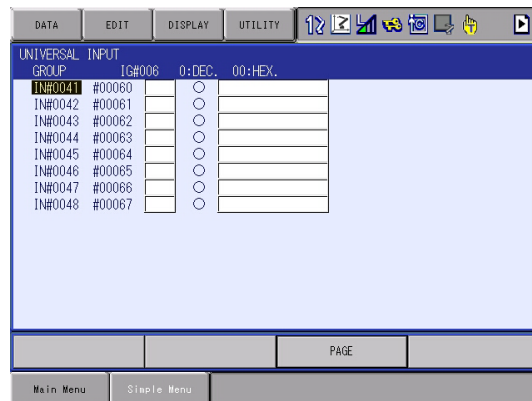

8.3.6.2 Search from the Menu

1. Select {EDIT} under the menu in the UNIVERSAL/SPECIFIED INPUT/OUTPUT window.
 - The pull-down menu appears.

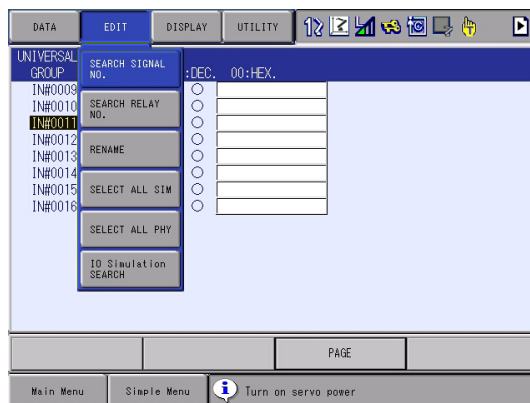

2. Select {SEARCH SIGNAL NO.}.
 - Numeric values can now be entered.

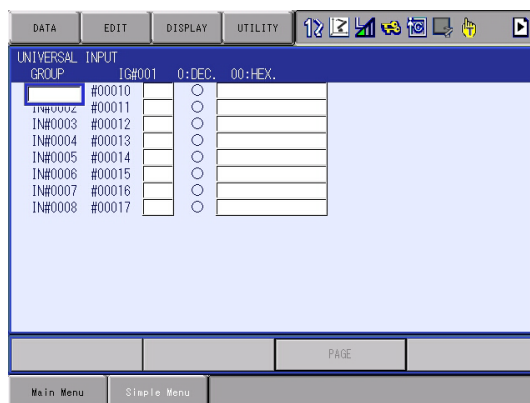

3. Enter the signal number to be searched.
 - Type the signal number in the number input line.
4. Press [ENTER] to start the search.
 - The page where the signal number exists appears.

8.3.7 Relay Number Search

A search can be made for a relay number of a universal input, universal output, system input, and system output.

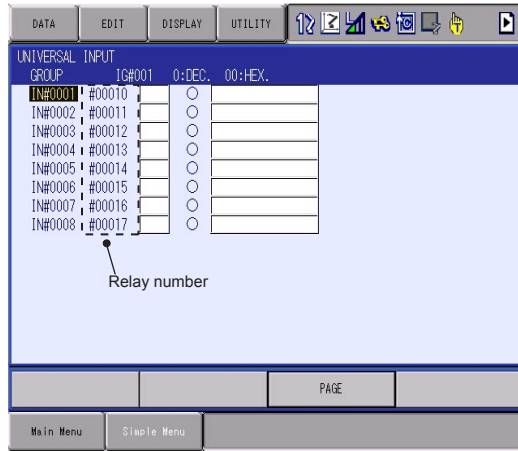

A search for the relay number can be made in the following two ways.

- Direct search on the UNIVERSAL/SPECIFIED INPUT/OUTPUT window
- Search from the menu

8.3.7.1 Direct Search on the Universal/Specified Input/Output Window

1. Move the cursor to a relay number in the UNIVERSAL/SPECIFIED INPUT/OUTPUT window, and press [SELECT].
 - Numeric values can now be entered.

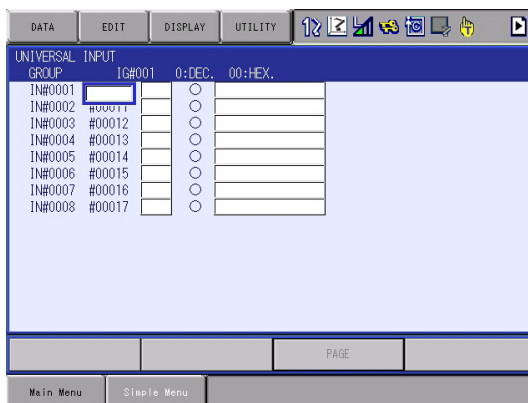

2. Enter the relay number to be searched.
 - Type the relay number in the number input line.
3. Press [ENTER] to start the search.
 - The page where the relay number exists appears.

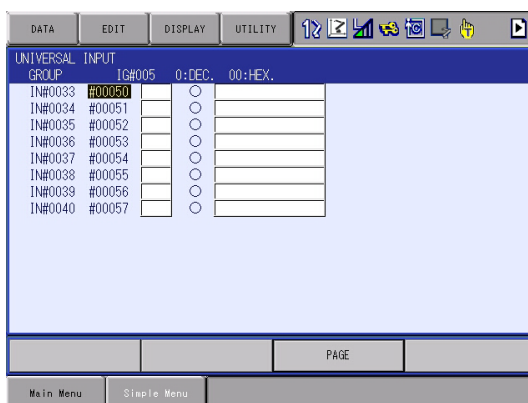

8.3.7.2 Search from the Menu

1. Select {EDIT} under the menu in the UNIVERSAL/SPECIFIED INPUT/OUTPUT window.
 - The pull-down menu appears.

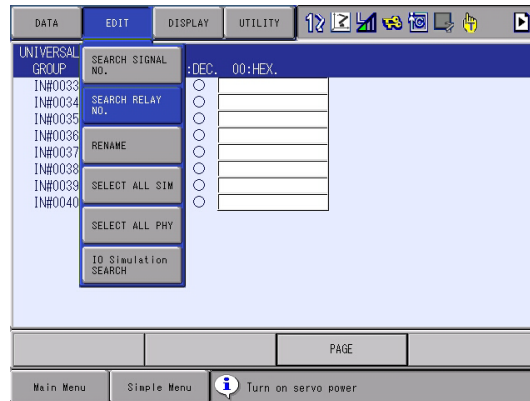

2. Select {SEARCH RELAY SIGNAL NO.}.
 - Numeric values can now be entered.

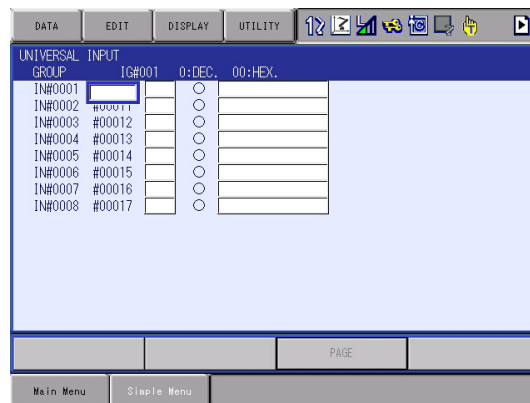

3. Enter the relay number to be searched.
 - Type the relay number in the number input line.
4. Press [ENTER] to start the search.
 - The page where the relay number exists appears.

8.3.8 Modification of the Signal Name

The name of the universal input or output signal can be modified.

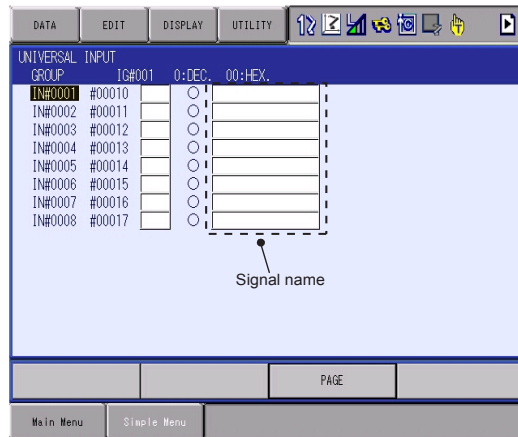

The name can be modified in the following two ways.

- Direct modification on the UNIVERSAL/SPECIFIED INPUT/OUTPUT window.
- Modification from the menu

8.3.8.1 Direct Modification on the Universal/Specified Input/Output Window

1. Move the cursor to the signal name to be modified in the UNIVERSAL/SPECIFIED INPUT/OUTPUT window, and press [SELECT].
 - The window for character input appears.
2. Enter the signal name.
3. Press [ENTER].
 - New signal name is registered.

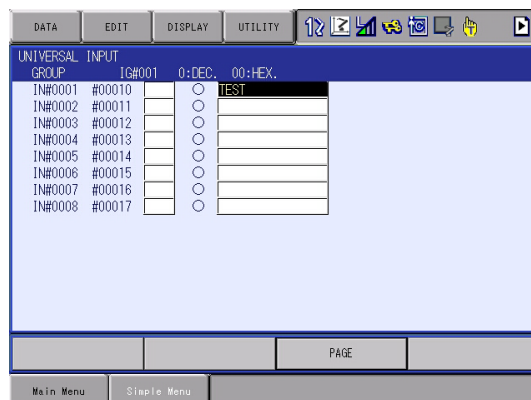

8.3.8.2 Modification from the Menu

1. Move the cursor to the signal name to be modified in the UNIVERSAL/SPECIFIED INPUT/OUTPUT window.
2. Select {EDIT} under the menu.
 - The pull-down menu appears.

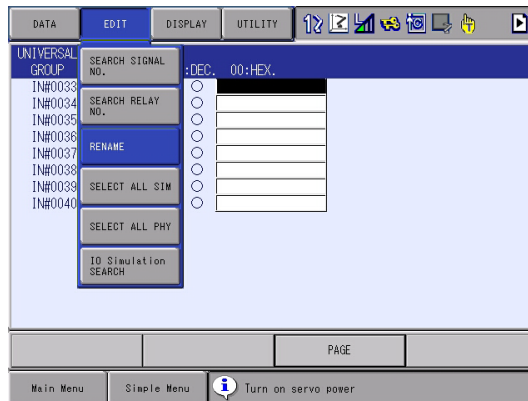

3. Select {RENAME}.
 - The window for character input appears.
4. Enter the signal name.
5. Press [ENTER].
 - New signal name is registered.

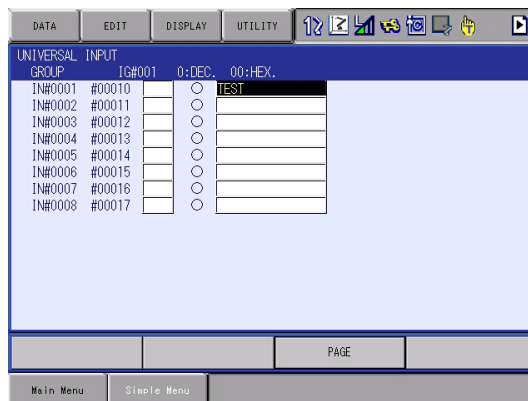

8.4 System Monitoring Time Display

8.4.1 System Monitoring Time Display Window

The status of system operation, e.g. power ON time, can be checked.

1. Select {SYSTEM INFO}.
2. Select {MONITORING TIME}.
 - The SYS MONITORING TIME window appears.

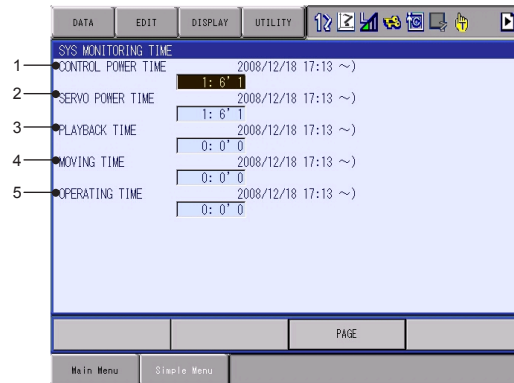

1. CONTROL POWER TIME

Displays the cumulative time that the main power supply has been ON.

2. SERVO POWER TIME

Displays the cumulative time that the servo power supply has been ON.

3. PLAYBACK TIME

Displays the cumulative time during which playback was executed.

4. MOVING TIME

Displays the cumulative time that the manipulator was in motion.

5. OPERATING TIME

Displays the cumulative time spent in operation.

8.4.2 Individual Window of the System Monitoring Time Display

If the page key  is pressed, or "PAGE" is selected to display the selection window for the system monitoring time display, the servo power time, playback time, moving time, and each-application operating time by each control group are individually displayed.

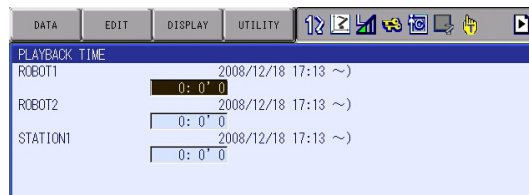
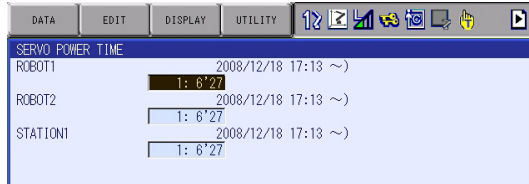

The total time of each control group here is not always the same as the time in the SYS MONITORING TIME window because these windows show time as seen from the individual control group.

8.4.3 Clearing the System Monitoring Time Display

The moving time and operating time can be cleared and set back to 0 by following procedure. These operations can be performed in the SYS MONITORING TIME window, or in the individual windows.

1. Select the time to be cleared.
 - The confirmation dialog box appears.

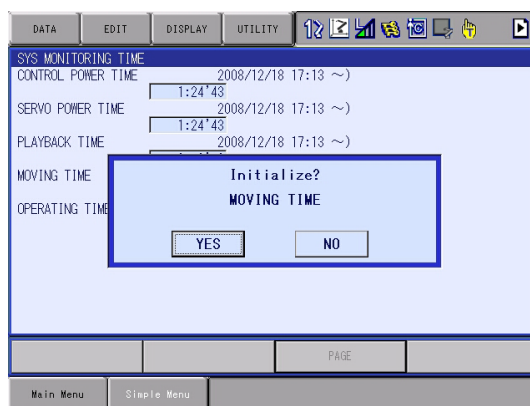

2. Select "YES".
 - The cumulative time value at the cursor line is reset to 0, and a new time measurement begins.

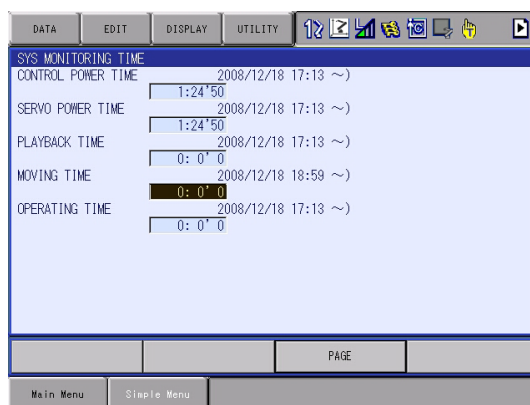



8.5 Alarm History

8.5.1 Alarm History Window

The alarm history can be confirmed in the alarm history window. There are five types of alarm history windows: the "MAJOR ALARM" window, the "MINOR ALARM" window, the "USER ALARM (SYSTEM)" window, the "USER ALARM (USER)" window, and the "OFF-LINE ALARM" window. Each window shows the alarm code and the date and time.

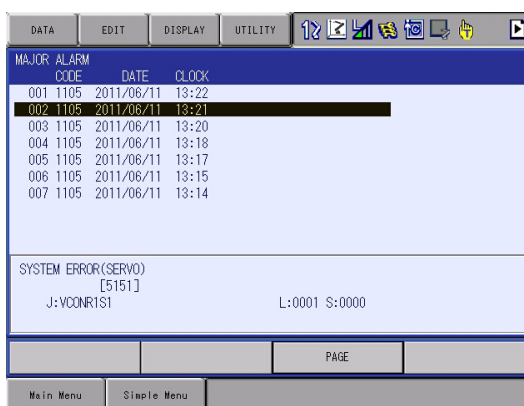
1. Select {SYSTEM INFO} under the main menu.
2. Select {ALARM HISTORY}.
 - The alarm history window appears.



3. Press the page key  to change the window, or select "PAGE" to display the selection window for the alarm windows.
 - Each time the page key  is pressed, the window changes "MAJOR ALARM"→"MINOR ALARM"→"USER ALARM(SYSTEM)"→"USER ALARM(USER)"→"OFF-LINE ALARM".

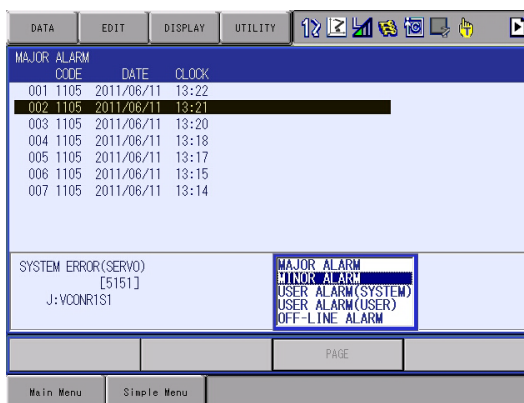

8.5.2 Clearing the Alarm History

The history of the minor alarms and the user alarms (system and user) can be cleared.

1. Display the alarm history window to be cleared.
2. Select {DATA} under the menu.
 - The pull-down menu "CLEAR HISTORY" appears.

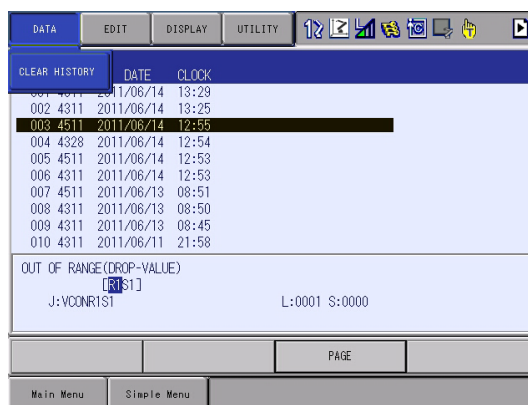

3. Select {CLEAR HISTORY}.
 - The confirmation dialog box appears.

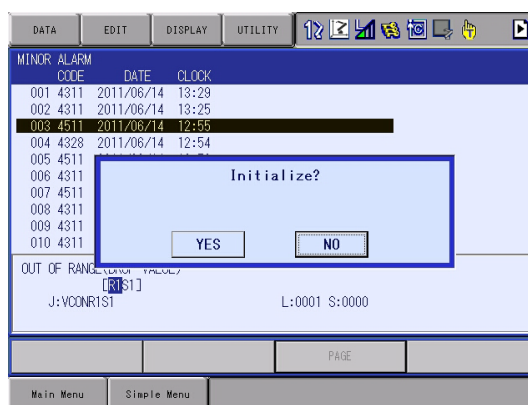

4. Select "YES".
 - The alarm history displayed is reset.

8.6 I/O Message History

8.6.1 I/O Message History Window

The I/O message history can be confirmed in the I/O MESSAGE HISTORY window.

The I/O MESSAGE HISTORY window shows the date and time, job name, line number, and step number of the I/O message that appeared on the window.

1. Select {SYSTEM INFO} under the main menu.
2. Select {I/O MSG HISTORY}
 - The I/O MESSAGE HISTORY window appears.

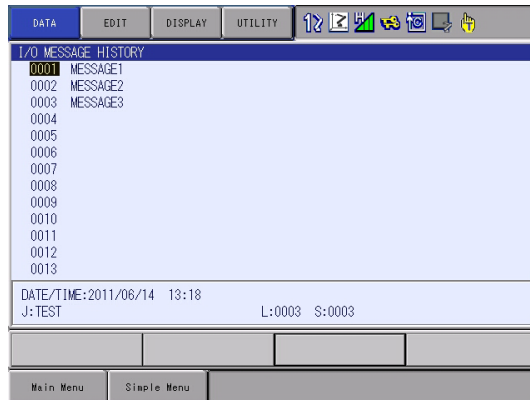

Press [SELECT], and numeric values can now be entered. Input the history number, and press [ENTER]. The search for the input history number begins, and the I/O message that appeared on the window is displayed.

8.6.1.1 Search

Use the following operation to search for the I/O message history.

1. Select {EDIT} under the menu.
2. Select {SEARCH}.
 - The character input line appears.
3. Enter the history No.
4. Press [ENTER].
 - The search for the input history number begins, and the I/O message is displayed.

8.6.2 Clearing the I/O Message History

Use the following operation to clear the I/O message history.

1. Select {DATA} under the menu.
2. Select {CLEAR HISTORY}.
 - The confirmation dialog box appears.

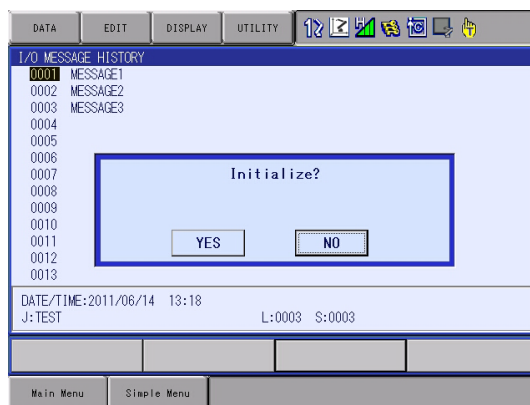

3. Select "YES".
 - The displayed I/O message history is cleared.

8.7 Position Data When Power is Turned ON/OFF

8.7.1 Power ON/OFF Position Window

The Power ON/OFF position window shows the position of the manipulator when power was turned OFF the last time, the current position of the manipulator when power was later turned ON, and the amount of difference between the two positions. When alarm 4107, "OUT OF RANGE (ABSOLUTE DATA)" occurs, the error value of the faulty axes can be verified in this window.

1. Select {ROBOT} under the main menu.
2. Select {POWER ON/OFF POS}.
 - The POWER ON/OFF POSITION window appears.

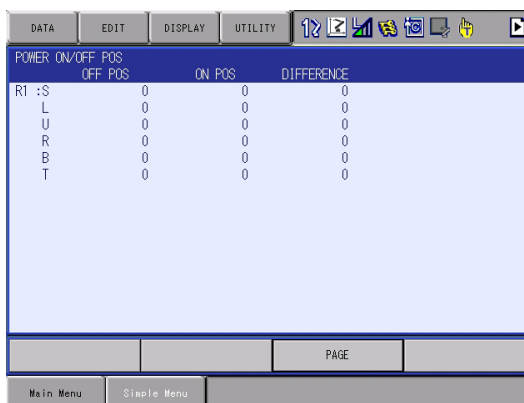

POWER ON/OFF POS			
	OFF POS	ON POS	DIFFERENCE
RT :S	0	0	0
L	0	0	0
U	0	0	0
R	0	0	0
B	0	0	0
T	0	0	0

8.8 Current Position

8.8.1 Current Position Window

1. Select {ROBOT} under the main menu.
2. Select {CURRENT POSITION} under the sub menu.
 - The CURRENT POSITION window appears.

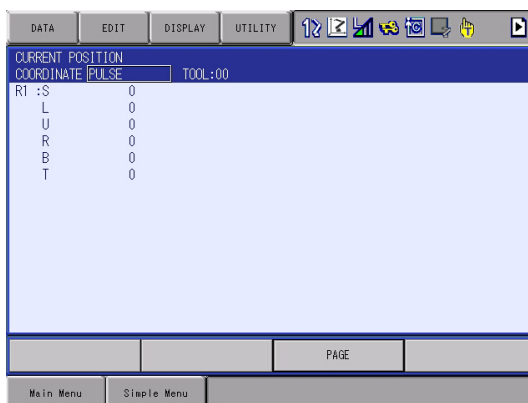

3. Select the types of coordinates to be displayed.
 - The pull-down menu appears.

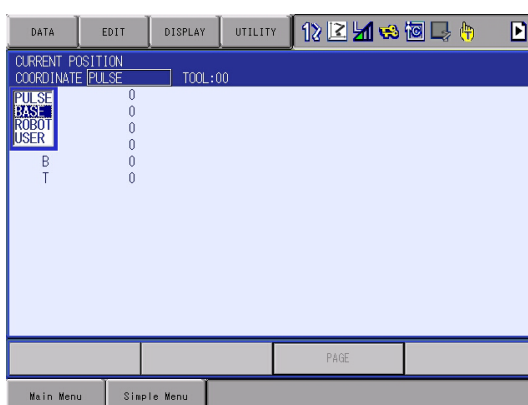

4. Select the desired coordinate system.
 - The type of coordinates being displayed is changed.

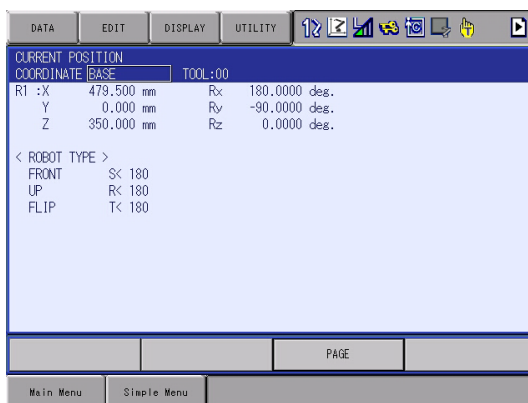

8.9 Servo Monitoring

8.9.1 Servo Monitor Window

The servo monitor window shows the servo-related data of each axis.

Monitor Items	Description
FEEDBACK PULSE	Feedback position (actual position) of each axis "0" at the home position
ERROR PULSE	Difference between the command position and the feedback position of each axis
SPEED DEVIATION	Difference between the command speed and the feedback speed of each axis
SPEED INST	Speed reference of each axis
FEEDBACK SPEED	Feedback speed (actual speed) of each axis
TORQUE SPEC	Torque reference of each axis
MAX. TORQUE	Keeps the maximum value of the torque reference of each axis. "0" when the maximum torque is cleared or the control power supply is turned ON or OFF
ENCODER ROTATE SUM	Accumulated number of encoder rotation when the control power supply of each axis is turned ON
IN 1 TURN POSITION	Position after one rotation of the encoder when the control power supply of each axis is turned ON
MOTOR ABSOLUTE	Absolute value of the motor is calculated by adding the position in one rotation to the sum of the accumulated rotations when the control power supply of each axis is turned ON.
ENCODER TEMPERATURE	Encoder temperature of each axis

8.9.1.1 Changing the Monitor Items

1. Set the security mode to the management mode.
2. Select {ROBOT} under the main menu.
3. Select {SERVO MONITOR}.
 - The SERVO MONITOR window appears.

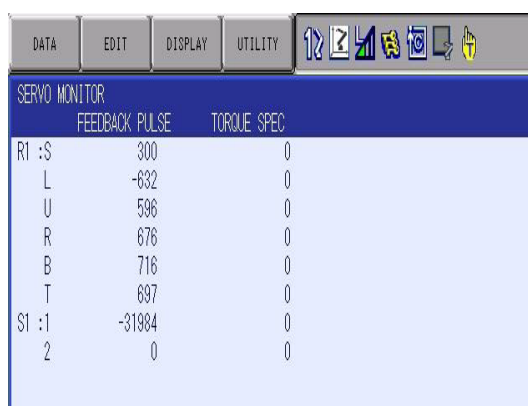

SERVO MONITOR		
	FEEDBACK PULSE	TORQUE SPEC
RI :S	300	0
L	-632	0
U	596	0
R	676	0
B	716	0
T	697	0
SI :1	-31884	0
2	0	0

4. Select {DISPLAY} under the menu.
 - The pull-down menu appears.
 - MONITOR ITEM 1 is the data on the left, and MONITOR ITEM 2 is the data on the right



SERVO MONITOR		
	ERROR PULSE	SPEC
RI :S		0
L		0
U		0
R	0	0
B	0	0
T	0	0
SI :1	0	0
2	0	0

5. Select MONITOR ITEM 1 or 2, and view the sub-menu choices by the cursor key.
 - The sub-menu choices appear.



6. Select a menu.
 - The type of monitor-related information is changed.

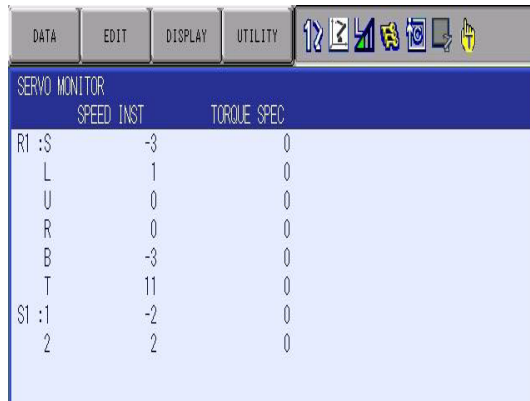

8.9.1.2 Clearing Maximum Torque Data

The data for the maximum torque can be cleared when the maximum torque-related information is being displayed.

1. Select {DATA} under the menu.
 - The clear max torque window appears



	TORQUE	TORQUE SPEC
L	179	0
U	2	0
R	12	0
B	2	0

2. Select {MAX. TORQUE}.
 - The maximum torque data is cleared.

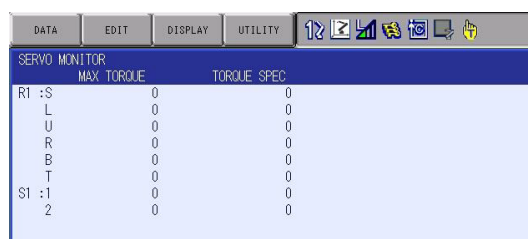

	MAX. TORQUE	TORQUE SPEC
R1 :S	0	0
L	0	0
U	0	0
R	0	0
B	0	0
T	0	0
S1 :1	0	0
2	0	0

9 Alarm

9.1 Outline of Alarm

When an alarm of level 0 to 3 (major alarm) occurs, the servo power supply is turned OFF.

Table 9-1: Alarm Code Classification

Alarm Code	Alarm Level	Alarm Reset Method
0□□□	Level 0 (Major alarm) (Off line alarm: Initial diagnosis/ Hardware diagnosis alarm)	It is not possible to reset by "RESET" under the ALARM window or the system input signal (Alarm reset). Turn OFF the main power supply and correct the cause of the alarm. Then turn ON the main power supply again.
1□□□ to 3□□□	Level 1 to 3 (Major alarm)	It is not possible to reset by "RESET" under the ALARM window or the system input signal (Alarm reset). Turn OFF the main power supply and correct the cause of the alarm. Then turn ON the main power supply again.
4□□□ to 8□□□	Level 4 to 8 (Minor alarm)	After correcting the cause, it is possible to reset by "RESET" under the ALARM window or the system input signal (Alarm reset).
9□□□	Level 9 (Minor alarm) (I/O alarm)	After correcting the cause for which the system input signal for the system or user alarm request turns ON, it is possible to reset by "RESET" under the ALARM window or the system input signal (Alarm reset).

9.2 Alarm Display

9.2.1 Displaying and Releasing Alarm

If an alarm occurs during operation, the manipulator stops immediately and the ALARM window appears on the programming pendant indicating that the machine was stopped by an alarm.

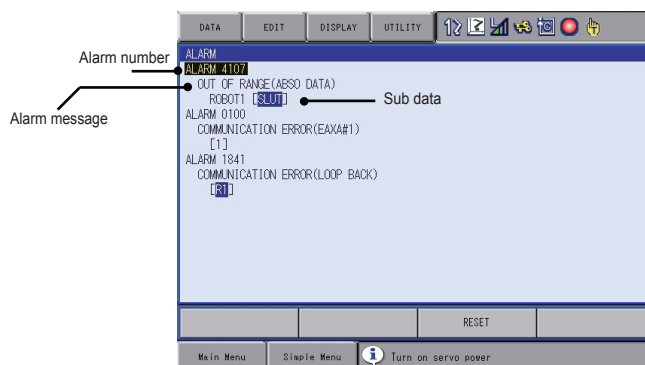

If more than one alarm occurs simultaneously, all the alarms are displayed.

Scroll the viewing area with the cursor to view the alarm that is not currently displayed on the viewing area.

The following operations are available in the alarm status: window change, mode change, alarm reset, and emergency stop. If the window is changed to another window during alarm occurrence, the ALARM window can be shown again by selecting {SYSTEM INFO} under the main menu and then selecting {ALARM}.

9.2.1.1 Releasing Alarms

Alarms are classified by minor and major alarms.

- Minor Alarms

Select "RESET" on the ALARM window to release alarms.
Or, turn ON the system signal "ALARM RESET" when using an external input signal (system input).

- Major Alarms

If a severe alarm such as hardware failure occurs, servo power is automatically shut OFF and the manipulator stops. Turn OFF the main power supply, remove the cause of the alarm, and then turn ON the power supply again.

9.2.2 Special Alarm Display

(1) Sub Data

Sub data such as data for the axis where the alarm occurred, may also be displayed for some alarms.

- Decimal data
Without signs: 0 to 65535
With signs: -32768 to 32767
- Binary data
The alarm occurrence data becomes "1".
With 8 bits: 0000_0001
With 16 bits: 00000001_00000001
- Axis data
The axis where the alarm occurred is highlighted.
With robot axis: Robots 1 to 2 [S **L** U R B T]
With base axis: Base 1 to 2 [**1** 2]
With station axis: Stations 1 to 3 [1 **2** 3]
- XYZ coordinate data
The coordinates where the alarm occurred are highlighted.
[**X** Y Z]
[X Y Z **T**x Ty Tz]
- 123 data
The data for which the alarm occurred is highlighted.
[**1** 2 3]
- Control group data
The control group where the alarm occurred is highlighted.
[**R**1 R2 S1 S2 S3]

(2) Multiple SERVO Control Board System

In a system using more than one SERVO control board, the number of the SERVO control board where the alarm occurred is also displayed.

The SERVO control board number is determined by its S2 switch.

SV#1: SERVO control board 1

SV#2: SERVO control board 2

(3) Independent Control Function (Optional)

In the independent control function (multi-task job), the tasks that were being done when the alarm occurred are also displayed.

TASK#0: Master-task job

TASK#1: Sub-task1 job (SUB1)

TASK#2: Sub-task2 job (SUB2)

TASK#3: Sub-task3 job (SUB3)

TASK#4: Sub-task4 job (SUB4)

TASK#5: Sub-task5 job (SUB5)

9.3 Display of Alarm Details

Alarm details displaying function indicates the alarm contents breakdown on the alarm window.

Press [Select] after moving the cursor to the subject alarm on the alarm window to display its “content”, “cause” and “measure”.

Skip displaying the alarm window to directly display this breakdown window is possible by specifying the parameter when an alarm occurs.

9.3.1 Parameter

S2C406 Alarm Details Direct Display 0: Invalid / 1: Valid

9.3.2 Display of Alarm Detail Window

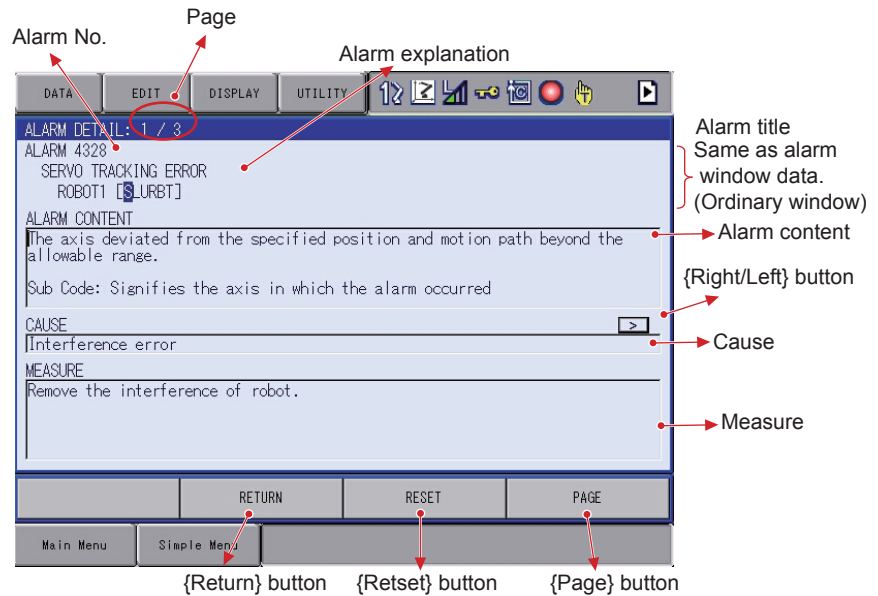

- **Page**
Displays the page number of the alarm whose detail window is currently displayed / the total alarm number occurred coincidentally.
- **Alarm No.**
Displays the alarm number with decimal 4 digit.
- **Sub data**
Displays the sub code number defined to each alarm.
- **Alarm content**
Displays the content of the alarm.

- **{Right/Left} button**
This button appears when there can be several “cause”s and “measure”s to one alarm. Press this to right/left ward to alternate the “cause” and the “measure”.
- **Cause**
Displays the cause of an alarm.
- **Measure**
Displays the recovery method from the alarming state.
- **{Reset} button**
Press this button to reset the alarm.
- **{Page} button**
Press this button to display the page number inputting area.
This area appears when several alarms occur at a time.

9.3.3 Transition of Alarm Detail Window

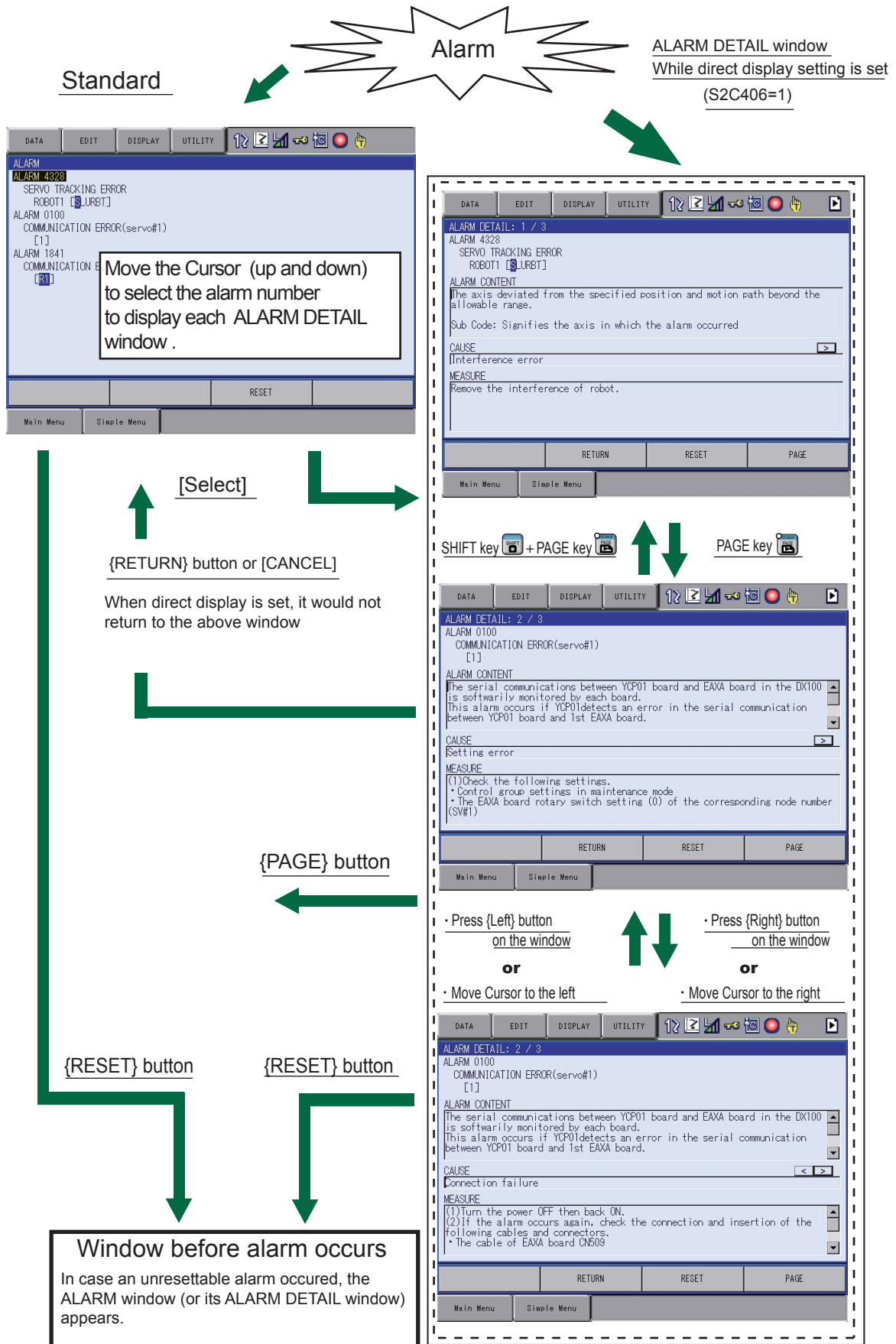

9.4 Alarm Message List



CAUTION

- Before handling the main CPU board (CPU-201R) for any remedies, personnel must be appropriately skilled in maintenance mode operation.
- CPU-201R is saving important file data for the user program through its battery backup operation. Contact your Yaskawa representatives when measures for CPU-201R alarms are considered to be needed. Careless operation may delete registered data.

Alarm Number	Alarm Name	Sub Code	Meaning	Cause	Remedy
20	CPU COMMUNICATION ERROR	1	No response was sent from the Main CPU board when the control power turned ON.	Software operation error occurred	(1)Turn the power OFF then back ON. (2)If the alarm occurs again, replace the controller. Save the CMOS.BIN before replacement to be safe.
				Main CPU board failure	(1)Turn the power OFF then back ON. (2)If the alarm occurs again, replace the controller. Save the CMOS.BIN before replacement to be safe.
		50	No response was sent from the servo board #1 when the control power turned ON. In this case, the FS100 may make wrong judgement that a signal such as external hold signal is input. However, it is caused by the communication error with Servo control board #1. Therefore, execute the following measure.	Setting error	(1)Turn the power OFF then back ON. (2)If the alarm occurs again, replace the controller. Save the CMOS.BIN before replacement to be safe.
				Connection failure	(1)Turn the power OFF then back ON (2)If the alarm occurs again, replace the controller. Save the CMOS.BIN before replacement to be safe.
				Servo control board failure	(1) Turn the power OFF then back ON. (2)If the alarm occurs again, replace the controller. Save the CMOS.BIN before replacement to be safe.
				Main CPU board failure	(1)Turn the power OFF then back ON. (2)If the alarm occurs again, replace the controller. Save the CMOS.BIN before replacement to be safe.
		51	No response was sent from the Servo control board #2 when the control power turned ON.	Setting error	(1)Turn the power OFF then back ON. (2)If the alarm occurs again, replace the controller. Save the CMOS.BIN before replacement to be safe.
				Connection failure	(1)Turn the power OFF then back ON. (2)If the alarm occurs again, replace the controller. Save the CMOS.BIN before replacement to be safe.
				Servo control board failure	(1)Turn the power OFF then back ON. (2)If the alarm occurs again, replace the controller. Save the CMOS.BIN before replacement to be safe.
				converter unit failure	(1)Turn the power OFF then back ON. (2)If the alarm occurs again, replace the controller. Save the CMOS.BIN before replacement to be safe.

Alarm Number	Alarm Name	Sub Code	Meaning	Cause	Remedy
				Main CPU board failure	(1)Turn the power OFF then back ON. (2)If the alarm occurs again, replace the controller. Save the CMOS.BIN before replacement to be safe.
21	COMMUNICATION ERROR (SERVO)	50	The communications CPU for the Servo control board #1 detected an error when the control power turned ON.	Setting error	(1)Turn the power OFF then back ON. (2)If the alarm occurs again, replace the controller. Save the CMOS.BIN before replacement to be safe.
				Connection failure	(1)Turn the power OFF then back ON. (2)If the alarm occurs again, replace the controller. Save the CMOS.BIN before replacement to be safe.
				Servo control board failure	(1)Turn the power OFF then back ON. (2)If the alarm occurs again, replace the controller. Save the CMOS.BIN before replacement to be safe.
				Main CPU board failure	(1)Turn the power OFF then back ON. (2)If the alarm occurs again, replace the controller. Save the CMOS.BIN before replacement to be safe.
		51	The communications CPU for the Servo control board #2 detected an error when the control power turned ON.	Setting error	(1)Turn the power OFF then back ON. (2)If the alarm occurs again, replace the controller. Save the CMOS.BIN before replacement to be safe.
				Connection failure	(1)Turn the power OFF then back ON. (2)If the alarm occurs again, replace the controller. Save the CMOS.BIN before replacement to be safe.
				Servo control board failure	(1)Turn the power OFF then back ON. (2)If the alarm occurs again, replace the controller. Save the CMOS.BIN before replacement to be safe.
				Main CPU board failure	(1)Turn the power OFF then back ON. (2)If the alarm occurs again, replace the controller. Save the CMOS.BIN before replacement to be safe.
30	ROM ERROR	1	The CPU-201R system program is damaged.	Software operation error occurred	(1)Turn the power OFF then back ON. (2)If the alarm occurs again, replace the controller. Save the CMOS.BIN before replacement to be safe.
		50	The system program of Servo control board #1 is damaged.	Software operation error occurred	(1)Turn the power OFF then back ON. (2)If the alarm occurs again, replace the controller. Save the CMOS.BIN before replacement to be safe.
				Servo control board failure	(1)Turn the power OFF then back ON. (2)If the alarm occurs again, replace the controller. Save the CMOS.BIN before replacement to be safe.

Alarm Number	Alarm Name	Sub Code	Meaning	Cause	Remedy
		51	The system program of Servo control board #2 is damaged.	Software operation error occurred	(1)Turn the power OFF then back ON. (2)If the alarm occurs again, replace the controller. Save the CMOS.BIN before replacement to be safe.
				Servo control board failure	(1)Turn the power OFF then back ON. (2)If the alarm occurs again, replace the controller. Save the CMOS.BIN before replacement to be safe.
60	COMMUNICATION ERROR (I/O MODULE)	0	The IO module board connected with 0th serial bus exists.	Software operation error occurred	(1)Turn the power OFF then back ON. (2)If the alarm occurs again, replace the controller. Save the CMOS.BIN before replacement to be safe.
				Main CPU board failure	(1)Turn the power OFF then back ON. (2)If the alarm occurs again, replace the controller. Save the CMOS.BIN before replacement to be safe.
		1	An error was detected in communications with the I/O module board connected with 1st serial bus when the control power turned ON.	Setting error	1)Check the following settings. ·The rotary switch setting which specifies slot numbers of each I/O module ·I/O module settings in maintenance mode
				Connection failure	(1)Turn the power OFF then back ON. (2)If the alarm occurs again, check the connecting or inserting state of the following cables or connectors. ·IO module cable of the corresponding slot. ·Terminator ·24V power of the corresponding IO module.
				Board failure (I/O module)	(1)Turn the power OFF then back ON. (2)If the alarm occurs again, replace the following board. Save the CMOS.BIN before replace the board to be safe.
				Main CPU board failure	(1)Turn the power OFF then back ON. (2)If the alarm occurs again, replace the controller. Save the CMOS.BIN before replacement to be safe.
		2	An error was detected in communications with the I/O module board connected with 2nd serial bus when the control power turned ON.	Setting error	(1)Check the following settings. ·The rotary switch setting which specifies slot numbers of each I/O module ·I/O module settings in maintenance mode

Alarm Number	Alarm Name	Sub Code	Meaning	Cause	Remedy
				Connection failure	(1)Turn the power OFF then back ON. (2)If the alarm occurs again, check the connecting or inserting state of the following cables or connectors. ·IO module cable of the corresponding slot. ·Terminator ·24V power of the corresponding IO module.
				Board failure (I/O module)	(1)Turn the power OFF then back ON. (2)If the alarm occurs again, replace the following board. Save the CMOS.BIN before replace the board to be safe.
				Main CPU board failure	(1)Turn the power OFF then back ON. (2)If the alarm occurs again, replace the controller. Save the CMOS.BIN before replacement to be safe.
		3	An error was detected in communications with the I/O module board connected with 3rd serial bus when the control power turned ON.	Setting error	(1)Check the following settings. ·The rotary switch setting which specifies slot numbers of each I/O module ·I/O module settings in maintenance mode
				Connection failure	(1)Turn the power OFF then back ON. (2)If the alarm occurs again, check the connecting or inserting state of the following cables or connectors. ·IO module cable of the corresponding slot. ·Terminator ·24V power of the corresponding IO module.
				Board failure (I/O module)	(1)Turn the power OFF then back ON. (2)If the alarm occurs again, replace the following board. Save the CMOS.BIN before replace the board to be safe.
				Main CPU board failure	(1)Turn the power OFF then back ON. (2)If the alarm occurs again, replace the controller. Save the CMOS.BIN before replacement to be safe.
		4	An error was detected in communications with the I/O module board connected with 4th serial bus when the control power turned ON.	Setting error	(1)Check the following settings. ·The rotary switch setting which specifies slot numbers of each I/O module ·I/O module settings in maintenance mode

Alarm Number	Alarm Name	Sub Code	Meaning	Cause	Remedy
				Connection failure	(1)Turn the power OFF then back ON. (2)If the alarm occurs again, check the connecting or inserting state of the following cables or connectors. ·IO module cable of the corresponding slot. ·Terminator ·24V power of the corresponding IO module.
				Board failure (I/O module)	(1)Turn the power OFF then back ON. (2)If the alarm occurs again, replace the following board. Save the CMOS.BIN before replace the board to be safe.
				Main CPU board failure	(1)Turn the power OFF then back ON. (2)If the alarm occurs again, replace the controller. Save the CMOS.BIN before replacement to be safe.
		5	An error was detected in communications with the I/O module board connected with 5th serial bus when the control power turned ON.	Setting error	(1)Check the following settings. ·The rotary switch setting which specifies slot numbers of each I/O module ·I/O module settings in maintenance mode
				Connection failure	(1)Turn the power OFF then back ON. (2)If the alarm occurs again, check the connecting or inserting state of the following cables or connectors. ·IO module cable of the corresponding slot. ·Terminator ·24V power of the corresponding IO module.
				Board failure (I/O module)	(1)Turn the power OFF then back ON. (2)If the alarm occurs again, replace the following board. Save the CMOS.BIN before replace the board to be safe.
				Main CPU board failure	(1)Turn the power OFF then back ON. (2)If the alarm occurs again, replace the controller. Save the CMOS.BIN before replacement to be safe.
		6	An error was detected in communications with the I/O module board connected with 6th serial bus when the control power turned ON.	Setting error	(1)Check the following settings. ·The rotary switch setting which specifies slot numbers of each I/O module ·I/O module settings in maintenance mode

Alarm Number	Alarm Name	Sub Code	Meaning	Cause	Remedy
				Connection failure	(1)Turn the power OFF then back ON. (2)If the alarm occurs again, check the connecting or inserting state of the following cables or connectors. ·IO module cable of the corresponding slot. ·Terminator ·24V power of the corresponding IO module.
				Board failure (I/O module)	(1)Turn the power OFF then back ON. (2)If the alarm occurs again, replace the following board. Save the CMOS.BIN before replace the board to be safe.
				Main CPU board failure	(1)Turn the power OFF then back ON. (2)If the alarm occurs again, replace the controller. Save the CMOS.BIN before replacement to be safe.
		7	An error was detected in communications with the I/O module board connected with 7th serial bus when the control power turned ON.	Setting error	(1)Check the following settings. ·The rotary switch setting which specifies slot numbers of each I/O module ·I/O module settings in maintenance mode
				Connection failure	(1)Turn the power OFF then back ON. (2)If the alarm occurs again, check the connecting or inserting state of the following cables or connectors. ·IO module cable of the corresponding slot. ·Terminator ·24V power of the corresponding IO module.
				Board failure(I/O module)	(1)Turn the power OFF then back ON. (2)If the alarm occurs again, replace the following board. Save the CMOS.BIN before replace the board to be safe.
				Main CPU board failure	(1)Turn the power OFF then back ON. (2)If the alarm occurs again, replace the controller. Save the CMOS.BIN before replacement to be safe.
		8	An error was detected in communications with the I/O module board connected with 8th serial bus when the control power turned ON.	Setting error	(1)Check the following settings. ·The rotary switch setting which specifies slot numbers of each I/O module ·I/O module settings in maintenance mode

Alarm Number	Alarm Name	Sub Code	Meaning	Cause	Remedy
				Connection failure	(1)Turn the power OFF then back ON. (2)If the alarm occurs again, check the connecting or inserting state of the following cables or connectors. ·IO module cable of the corresponding slot. ·Terminator ·24V power of the corresponding IO module.
				Board failure (I/O module)	(1)Turn the power OFF then back ON. (2)If the alarm occurs again, replace the following board. Save the CMOS.BIN before replace the board to be safe.
				Main CPU board failure	(1)Turn the power OFF then back ON. (2)If the alarm occurs again, replace the controller. Save the CMOS.BIN before replacement to be safe.
100	COMMUNICATION ERROR (servo#1)	1	The error was detected during the check of the serial communication watchdog data. Counter value received from Servo control board is invalid.	Setting error	(1)Turn the power OFF then back ON. (2)If the alarm occurs again, replace the controller. Save the CMOS.BIN before replacement to be safe.
				Connection failure	(1)Turn the power OFF then back ON. (2)If the alarm occurs again, replace the controller. Save the CMOS.BIN before replacement to be safe.
				Servo control board failure	(1)Turn the power OFF then back ON. (2)If the alarm occurs again, replace the controller. Save the CMOS.BIN before replacement to be safe.
				Main CPU board failure	(1)Turn the power OFF then back ON. (2)If the alarm occurs again, replace the controller. Save the CMOS.BIN before replacement to be safe.
		2	The error was detected during the check of the number of the serial communications. Counter value received from Servo control board is OFF by one cycle.	Setting error	(1)Turn the power OFF then back ON. (2)If the alarm occurs again, replace the controller. Save the CMOS.BIN before replacement to be safe.
				Connection failure	(1)Turn the power OFF then back ON. (2)If the alarm occurs again, replace the controller. Save the CMOS.BIN before replacement to be safe.
				Servo control board failure	(1)Turn the power OFF then back ON. (2)If the alarm occurs again, replace the controller. Save the CMOS.BIN before replacement to be safe.

Alarm Number	Alarm Name	Sub Code	Meaning	Cause	Remedy
				Main CPU board failure	(1)Turn the power OFF then back ON. (2)If the alarm occurs again, replace the controller. Save the CMOS.BIN before replacement to be safe.
101	COMMUNICATION ERROR (servo#2)	1	The error was detected during the check of the serial communication watchdog data. Counter value received from Servo control board is invalid.	Setting error	(1)Turn the power OFF then back ON. (2)If the alarm occurs again, replace the controller. Save the CMOS.BIN before replacement to be safe.
				Connection failure	(1)Turn the power OFF then back ON. (2)If the alarm occurs again, replace the controller. Save the CMOS.BIN before replacement to be safe.
				Servo control board failure	(1)Turn the power OFF then back ON. (2)If the alarm occurs again, replace the controller. Save the CMOS.BIN before replacement to be safe.
				Converter unit failure	(1)Turn the power OFF then back ON. (2)If the alarm occurs again, replace the controller. Save the CMOS.BIN before replacement to be safe.
				Main CPU board failure	(1)Turn the power OFF then back ON. (2)If the alarm occurs again, replace the controller. Save the CMOS.BIN before replacement to be safe.
		2	The error was detected during the check of the number of the serial communications. Counter value received from Servo control board is OFF by one cycle.	Setting error	(1)Turn the power OFF then back ON. (2)If the alarm occurs again, replace the controller. Save the CMOS.BIN before replacement to be safe.
				Connection failure	(1)Turn the power OFF then back ON. (2)If the alarm occurs again, replace the controller. Save the CMOS.BIN before replacement to be safe.
				Servo control board failure	(1)Turn the power OFF then back ON. (2)If the alarm occurs again, replace the controller. Save the CMOS.BIN before replacement to be safe.
				Converter unit failure	(1)Turn the power OFF then back ON. (2)If the alarm occurs again, replace the controller. Save the CMOS.BIN before replacement to be safe.
				Main CPU board failure	(1)Turn the power OFF then back ON. (2)If the alarm occurs again, replace the controller. Save the CMOS.BIN before replacement to be safe.

Alarm Number	Alarm Name	Sub Code	Meaning	Cause	Remedy
200	MEMORY ERROR (PARAMETER FILE)	0	The RC parameter is damaged.	Data error	(1)Turn the power OFF then back ON. (2)If the alarm occurs again, initialize the appropriate data in maintenance mode, and then load the data saved in the external memory device.
				Main CPU board failure	(1)Turn the power OFF then back ON. (2)If the alarm occurs again, replace the controller. Save the CMOS.BIN before replacement to be safe.
		1	The RO parameter is damaged.	Data error	(1)Turn the power OFF then back ON. (2)If the alarm occurs again, initialize the appropriate data in maintenance mode, and then load the data saved in the external memory device.
				Main CPU board failure	(1)Turn the power OFF then back ON. (2)If the alarm occurs again, replace the controller. Save the CMOS.BIN before replacement to be safe.
		2	The SV parameter is damaged.	Data error	(1)Turn the power OFF then back ON. (2)If the alarm occurs again, initialize the appropriate data in maintenance mode, and then load the data saved in the external memory device.
				Main CPU board failure	(1)Turn the power OFF then back ON. (2)If the alarm occurs again, replace the controller. Save the CMOS.BIN before replacement to be safe.
		3	The SVM parameter is damaged.	Data error	(1)Turn the power OFF then back ON. (2)If the alarm occurs again, initialize the appropriate data in maintenance mode, and then load the data saved in the external memory device.
				Main CPU board failure	(1)Turn the power OFF then back ON. (2)If the alarm occurs again, replace the controller. Save the CMOS.BIN before replacement to be safe.
		4	The SC parameter is damaged.	Data error	(1)Turn the power OFF then back ON. (2)If the alarm occurs again, initialize the appropriate data in maintenance mode, and then load the data saved in the external memory device.
				Main CPU board failure	(1)Turn the power OFF then back ON. (2)If the alarm occurs again, replace the controller. Save the CMOS.BIN before replacement to be safe.
		5	The SD parameter is damaged.	Data error	(1)Turn the power OFF then back ON. (2)If the alarm occurs again, initialize the appropriate data in maintenance mode, and then load the data saved in the external memory device.
				Main CPU board failure	(1)Turn the power OFF then back ON. (2)If the alarm occurs again, replace the controller. Save the CMOS.BIN before replacement to be safe.

Alarm Number	Alarm Name	Sub Code	Meaning	Cause	Remedy
		6	The CIO parameter is damaged.	Data error	(1)Turn the power OFF then back ON. (2)If the alarm occurs again, initialize the appropriate data in maintenance mode, and then load the data saved in the external memory device.
				Main CPU board failure	(1)Turn the power OFF then back ON. (2)If the alarm occurs again, replace the controller. Save the CMOS.BIN before replacement to be safe.
		7	The FD parameter is damaged.	Data error	(1)Turn the power OFF then back ON. (2)If the alarm occurs again, initialize the appropriate data in maintenance mode, and then load the data saved in the external memory device.
				Main CPU board failure	(1)Turn the power OFF then back ON. (2)If the alarm occurs again, replace the controller. Save the CMOS.BIN before replacement to be safe.
		8	The AP parameter is damaged.	Data error	(1)Turn the power OFF then back ON. (2)If the alarm occurs again, initialize the appropriate data in maintenance mode, and then load the data saved in the external memory device.
				Main CPU board failure	(1)Turn the power OFF then back ON. (2)If the alarm occurs again, replace the controller. Save the CMOS.BIN before replacement to be safe.
		9	The RS parameter is damaged.	Data error	(1)Turn the power OFF then back ON. (2)If the alarm occurs again, initialize the appropriate data in maintenance mode, and then load the data saved in the external memory device.
				Main CPU board failure	(1)Turn the power OFF then back ON. (2)If the alarm occurs again, replace the controller. Save the CMOS.BIN before replacement to be safe.
		10	The SE parameter is damaged.	Data error	(1)Turn the power OFF then back ON. (2)If the alarm occurs again, initialize the appropriate data in maintenance mode, and then load the data saved in the external memory device.
				Main CPU board failure	(1)Turn the power OFF then back ON. (2)If the alarm occurs again, replace the controller. Save the CMOS.BIN before replacement to be safe.
		11	The SVC parameter is damaged.	Data error	(1)Turn the power OFF then back ON. (2)If the alarm occurs again, initialize the appropriate data in maintenance mode, and then load the data saved in the external memory device.
				Main CPU board failure	(1)Turn the power OFF then back ON. (2)If the alarm occurs again, replace the controller. Save the CMOS.BIN before replacement to be safe.

Alarm Number	Alarm Name	Sub Code	Meaning	Cause	Remedy
		12	The AMC parameter is damaged.	Data error	(1)Turn the power OFF then back ON. (2)If the alarm occurs again, initialize the appropriate data in maintenance mode, and then load the data saved in the external memory device.
				Main CPU board failure	(1)Turn the power OFF then back ON. (2)If the alarm occurs again, replace the controller. Save the CMOS.BIN before replacement to be safe.
		13	The SVP parameter is damaged.	Data error	(1)Turn the power OFF then back ON. (2)If the alarm occurs again, initialize the appropriate data in maintenance mode, and then load the data saved in the external memory device.
				Main CPU board failure	(1)Turn the power OFF then back ON. (2)If the alarm occurs again, replace the controller. Save the CMOS.BIN before replacement to be safe.
		14	The MF parameter is damaged.	Data error	(1)Turn the power OFF then back ON. (2)If the alarm occurs again, initialize the appropriate data in maintenance mode, and then load the data saved in the external memory device.
				Main CPU board failure	(1)Turn the power OFF then back ON. (2)If the alarm occurs again, replace the controller. Save the CMOS.BIN before replacement to be safe.
		15	The SVS parameter is damaged.	Data error	(1)Turn the power OFF then back ON. (2)If the alarm occurs again, initialize the appropriate data in maintenance mode, and then load the data saved in the external memory device.
				Main CPU board failure	(1)Turn the power OFF then back ON. (2)If the alarm occurs again, replace the controller. Save the CMOS.BIN before replacement to be safe.
210	MEMORY ERROR (SYSTEM CONFIG-DATA)		The system configuration information data are damaged.	Main CPU board failure	(1)Turn the power OFF then back ON. (2)If the alarm occurs again, replace the controller. Save the CMOS.BIN before replacement to be safe.
220	MEMORY ERROR (JOB MNG DATA)	0	The management data of job files are damaged.	Data error	(1)Turn the power OFF then back ON. (2)If the alarm occurs again, initialize the job file in maintenance mode, and then load the data (job, variable data, Robot calibration data) saved in the external memory device.
				Main CPU board failure	(1)Turn the power OFF then back ON. (2)If the alarm occurs again, replace the controller. Save the CMOS.BIN before replacement to be safe.
		1	The job files are damaged.	Data error	(1)Turn the power OFF then back ON. (2)If the alarm occurs again, initialize the job file in maintenance mode, and then load the data (job, variable data, Robot calibration data) saved in the external memory device.

Alarm Number	Alarm Name	Sub Code	Meaning	Cause	Remedy
				Main CPU board failure	(1)Turn the power OFF then back ON. (2)If the alarm occurs again, replace the controller. Save the CMOS.BIN before replacement to be safe.
		2	The management data of position data files are damaged.	Data error	(1)Turn the power OFF then back ON. (2)If the alarm occurs again, initialize the job file in maintenance mode, and then load the data (job, variable data, Robot calibration data) saved in the external memory device.
				Main CPU board failure	(1)Turn the power OFF then back ON. (2)If the alarm occurs again, replace the controller. Save the CMOS.BIN before replacement to be safe.
		3	Memory and play back file is damaged.	Data error	(1)Turn the power OFF then back ON. (2)If the alarm occurs again, initialize the appropriate data in maintenance mode, and then load the data saved in the external memory device.
				Main CPU board failure	(1)Turn the power OFF then back ON. (2)If the alarm occurs again, replace the controller. Save the CMOS.BIN before replacement to be safe.
230	MEMORY ERROR (LADDER PRG FILE)		The CIO ladder file is damaged.	Data error	(1)Turn the power OFF then back ON. (2)If the alarm occurs again, initialize the appropriate data in maintenance mode, and then load the data saved in the external memory device.
				Main CPU board failure	(1)Turn the power OFF then back ON. (2)If the alarm occurs again, replace the controller. Save the CMOS.BIN before replacement to be safe.
290	MEMORY ERROR (NETWORK SETUP)		The network setting file is damaged.	Data error	(1)Turn the power OFF then back ON. (2)If the alarm occurs again, initialize the appropriate data in maintenance mode, and then set the network again.
				Main CPU board failure	(1)Turn the power OFF then back ON. (2)If the alarm occurs again, replace the controller. Save the CMOS.BIN before replacement to be safe.
300	VERIFY ERROR (SYSTEM CONFIG-DATA)	2	CIO parameter error.	Setting error	(1)Check the following settings. ·I/O module settings in maintenance mode
				Main CPU board failure	(1)Turn the power OFF then back ON. (2)If the alarm occurs again, replace the controller. Save the CMOS.BIN before replacement to be safe.
		4	Axis-related parameter error.	Setting error	(1)Check the following settings. ·Control group settings in maintenance mode

Alarm Number	Alarm Name	Sub Code	Meaning	Cause	Remedy
				Main CPU board failure	(1)Turn the power OFF then back ON. (2)If the alarm occurs again, replace the controller. Save the CMOS.BIN before replacement to be safe.
		5	Sensor-use parameter error.	Setting error	(1)Check the following settings. -The optional board setting in maintenance mode
				Main CPU board failure	(1)Turn the power OFF then back ON. (2)If the alarm occurs again, replace the controller. Save the CMOS.BIN before replacement to be safe.
		7	The set optional functions are different from those of the mounted optional board.	Setting error	(1)Check the following settings. -The optional board setting in maintenance mode
				Main CPU board failure	(1)Turn the power OFF then back ON. (2)If the alarm occurs again, replace the controller. Save the CMOS.BIN before replacement to be safe.
		8	IO type error (combination impossible to coexist).	Setting error	(1)Check the following settings. -I/O module settings in maintenance mode
				Main CPU board failure	(1)Turn the power OFF then back ON. (2)If the alarm occurs again, replace the controller. Save the CMOS.BIN before replacement to be safe.
301	VERIFY ERROR (OVERRUN INPUT SET)		Sub Code: Control group Parameter specification and OT signal information are wrong	Setting error	(1)Check the following settings. -Connection settings (OT) in maintenance mode
310	VERIFY ERROR (CMOS MEMORY)	0	The CMOS memory version is different from its initial setting.	Setting error	(1)Check the following settings. -Set the security mode to MANAGEMENT MODE. -Data rebuild in maintenance mode
				Main CPU board failure	(1)Turn the power OFF then back ON. (2)If the alarm occurs again, replace the controller. Save the CMOS.BIN before replacement to be safe.
		1	The CRC data in CMOS memory and the CRC data calculated by the system software are inconsistent.	Setting error	(1)Check the following settings. -Set the security mode to MANAGEMENT MODE. -Data rebuild in maintenance mode
				Main CPU board failure	(1)Turn the power OFF then back ON. (2)If the alarm occurs again, replace the controller. Save the CMOS.BIN before replacement to be safe.

Alarm Number	Alarm Name	Sub Code	Meaning	Cause	Remedy
320	VERIFY ERROR (I/O MODULE)	1	The I/O module connected to the serial bus #1 is different from the function of the set I/O module.	Setting error	(1)Check the following settings. ·The rotary switch setting which specifies slot numbers of each I/O module ·I/O module settings in maintenance mode
				Connection failure	(1)Turn the power OFF then back ON. (2)If the alarm occurs again, check the connecting or inserting state of the following cables or connectors. ·IO module cable of the corresponding slot. ·Terminator ·24V power of the corresponding IO module.
				Board failure (I/O module)	(1)Turn the power OFF then back ON. (2)If the alarm occurs again, replace the following board. Save the CMOS.BIN before replace the board to be safe. ·Corresponding IO module
				Main CPU board failure	(1)Turn the power OFF then back ON. (2)If the alarm occurs again, replace the controller. Save the CMOS.BIN before replacement to be safe.
		2	The I/O module connected to the serial bus #2 is different from the function of the set I/O module.	Setting error	(1)Check the following settings. ·The rotary switch setting which specifies slot numbers of each I/O module ·I/O module settings in maintenance mode
				Connection failure	(1)Turn the power OFF then back ON. (2)If the alarm occurs again, check the connecting or inserting state of the following cables or connectors. ·IO module cable of the corresponding slot. ·Terminator ·24V power of the corresponding IO module.
				Board failure (I/O module)	(1)Turn the power OFF then back ON. (2)If the alarm occurs again, replace the following board. Save the CMOS.BIN before replace the board to be safe. ·Corresponding IO module
				Main CPU board failure	(1)Turn the power OFF then back ON. (2)If the alarm occurs again, replace the controller. Save the CMOS.BIN before replacement to be safe.
		3	The I/O module connected to the serial bus #3 is different from the function of the set I/O module.	Setting error	(1)Check the following settings. ·The rotary switch setting which specifies slot numbers of each I/O module ·I/O module settings in maintenance mode

Alarm Number	Alarm Name	Sub Code	Meaning	Cause	Remedy
				Connection failure	(1)Turn the power OFF then back ON. (2)If the alarm occurs again, check the connecting or inserting state of the following cables or connectors. ·IO module cable of the corresponding slot. ·Terminator ·24V power of the corresponding IO module.
				Board failure (I/O module)	(1)Turn the power OFF then back ON. (2)If the alarm occurs again, replace the following board. Save the CMOS.BIN before replace the board to be safe. ·Corresponding IO module
				Main CPU board failure	(1)Turn the power OFF then back ON. (2)If the alarm occurs again, replace the controller. Save the CMOS.BIN before replacement to be safe.
		4	The I/O module connected to the serial bus #4 is different from the function of the set I/O module.	Setting error	(1)Check the following settings. ·The rotary switch setting which specifies slot numbers of each I/O module ·I/O module settings in maintenance mode
				Connection failure	(1)Turn the power OFF then back ON. (2)If the alarm occurs again, check the connecting or inserting state of the following cables or connectors. ·IO module cable of the corresponding slot. ·Terminator ·24V power of the corresponding IO module.
				Board failure (I/O module)	(1)Turn the power OFF then back ON. (2)If the alarm occurs again, replace the following board. Save the CMOS.BIN before replace the board to be safe. ·Corresponding IO module
				Main CPU board failure	(1)Turn the power OFF then back ON. (2)If the alarm occurs again, replace the controller. Save the CMOS.BIN before replacement to be safe.
		5	The I/O module connected to the serial bus #5 is different from the function of the set I/O module.	Setting error	(1)Check the following settings. ·The rotary switch setting which specifies slot numbers of each I/O module ·I/O module settings in maintenance mode
				Connection failure	(1)Turn the power OFF then back ON. (2)If the alarm occurs again, check the connecting or inserting state of the following cables or connectors. ·IO module cable of the corresponding slot. ·Terminator ·24V power of the corresponding IO module.

Alarm Number	Alarm Name	Sub Code	Meaning	Cause	Remedy
				Board failure (I/O module)	(1)Turn the power OFF then back ON. (2)If the alarm occurs again, replace the following board. Save the CMOS.BIN before replace the board to be safe. ·Corresponding IO module
				Main CPU board failure	(1)Turn the power OFF then back ON. (2)If the alarm occurs again, replace the controller. Save the CMOS.BIN before replacement to be safe.
		6	The I/O module connected to the serial bus #6 is different from the function of the set I/O module.	Setting error	(1)Check the following settings. ·The rotary switch setting which specifies slot numbers of each I/O module ·I/O module settings in maintenance mode
				Connection failure	(1)Turn the power OFF then back ON. (2)If the alarm occurs again, check the connecting or inserting state of the following cables or connectors. ·IO module cable of the corresponding slot. ·Terminator ·24V power of the corresponding IO module.
				Board failure(I/O module)	(1)Turn the power OFF then back ON. (2)If the alarm occurs again, replace the following board. Save the CMOS.BIN before replace the board to be safe. ·Corresponding IO module
				Main CPU board failure	(1)Turn the power OFF then back ON. (2)If the alarm occurs again, replace the controller. Save the CMOS.BIN before replacement to be safe.
		7	The I/O module connected to the serial bus #7 is different from the function of the set I/O module.	Setting error	(1)Check the following settings. ·The rotary switch setting which specifies slot numbers of each I/O module ·I/O module settings in maintenance mode
				Connection failure	(1)Turn the power OFF then back ON. (2)If the alarm occurs again, check the connecting or inserting state of the following cables or connectors. ·IO module cable of the corresponding slot. ·Terminator ·24V power of the corresponding IO module.
				Board failure(I/O module)	(1)Turn the power OFF then back ON. (2)If the alarm occurs again, replace the following board. Save the CMOS.BIN before replace the board to be safe. ·Corresponding IO module

Alarm Number	Alarm Name	Sub Code	Meaning	Cause	Remedy
				Main CPU board failure	(1)Turn the power OFF then back ON. (2)If the alarm occurs again, replace the controller. Save the CMOS.BIN before replacement to be safe.
		8	The I/O module connected to the serial bus #8 is different from the function of the set I/O module.	Setting error	(1)Check the following settings. ·The rotary switch setting which specifies slot numbers of each I/O module ·I/O module settings in maintenance mode
				Connection failure	(1)Turn the power OFF then back ON. (2)If the alarm occurs again, check the connecting or inserting state of the following cables or connectors. ·IO module cable of the corresponding slot. ·Terminator ·24V power of the corresponding IO module.
				Board failure (I/O module)	(1)Turn the power OFF then back ON. (2)If the alarm occurs again, replace the following board. Save the CMOS.BIN before replace the board to be safe. ·Corresponding IO module
				Main CPU board failure	(1)Turn the power OFF then back ON. (2)If the alarm occurs again, replace the controller. Save the CMOS.BIN before replacement to be safe.
330	VERIFY ERROR (APPLICATION)			Main CPU board failure	(1)Turn the power OFF then back ON. (2)If the alarm occurs again, replace the controller. Save the CMOS.BIN before replacement to be safe.
390	VERIFY ERROR (SEGMENT CLOCK)		Illegal instruction cycle is set.	Setting error	(1)Check the following settings. ·Instruction execution cycle
				Main CPU board failure	(1)Turn the power OFF then back ON. (2)If the alarm occurs again, replace the controller. Save the CMOS.BIN before replacement to be safe.
400	PARAMETER TRANSMISSION ERROR	50	An error occurred during the parameter/file transfer to the 1st Servo control board.	Setting error	(1)Check the following settings. ·Control group settings in maintenance mode ·The Servo control board rotary switch setting (0) of the corresponding node number (SV#1)
				Connection failure	(1)Turn the power OFF then back ON. (2)If the alarm occurs again, replace the controller. Save the CMOS.BIN before replacement to be safe.
				Servo control board failure	(1)Turn the power OFF then back ON. (2)If the alarm occurs again, replace the controller. Save the CMOS.BIN before replacement to be safe.

Alarm Number	Alarm Name	Sub Code	Meaning	Cause	Remedy
				Main CPU board failure	(1)Turn the power OFF then back ON. (2)If the alarm occurs again, replace the controller. Save the CMOS.BIN before replacement to be safe.
		51	An error occurred during the parameter/file transfer to the 2nd Servo control board.	Setting error	(1)Check the following settings. ·Control group settings in maintenance mode ·The Servo control board rotary switch setting (1) of the corresponding node number (SV#2)
				Connection failure	(1)Turn the power OFF then back ON. (2)If the alarm occurs again, replace the controller. Save the CMOS.BIN before replacement to be safe.
				Servo control board failure	(1)Turn the power OFF then back ON. (2)If the alarm occurs again, replace the controller. Save the CMOS.BIN before replacement to be safe.
				Main CPU board failure	(1)Turn the power OFF then back ON. (2)If the alarm occurs again, replace the controller. Save the CMOS.BIN before replacement to be safe.
410	MODE CHANGE ERROR	50	An error occurred during startup sequence processing with the servo CPU of 1st Servo control board, and the system did not startup normally.	Setting error	(1)Check the following settings. ·Control group settings in maintenance mode ·The Servo control board rotary switch setting (0) of the corresponding node number (SV#1)
				Connection failure	(1)Turn the power OFF then back ON. (2)If the alarm occurs again, replace the controller. Save the CMOS.BIN before replacement to be safe.
				Servo control board failure	(1)Turn the power OFF then back ON. (2)If the alarm occurs again, replace the controller. Save the CMOS.BIN before replacement to be safe.
				Main CPU board failure	(1)Turn the power OFF then back ON. (2)If the alarm occurs again, replace the controller. Save the CMOS.BIN before replacement to be safe.
		51	An error occurred during startup sequence processing with the servo CPU of 2nd Servo control board, and the system did not startup normally.	Setting error	(1)Check the following settings. ·Control group settings in maintenance mode ·The Servo control board rotary switch setting (1) of the corresponding node number (SV#2)
				Connection failure	(1)Turn the power OFF then back ON. (2)If the alarm occurs again, replace the controller. Save the CMOS.BIN before replacement to be safe.

Alarm Number	Alarm Name	Sub Code	Meaning	Cause	Remedy
				Servo control board failure	(1)Turn the power OFF then back ON. (2)If the alarm occurs again, replace the controller. Save the CMOS.BIN before replacement to be safe.
				Main CPU board failure	(1)Turn the power OFF then back ON. (2)If the alarm occurs again, replace the controller. Save the CMOS.BIN before replacement to be safe.
500	SEGMENT PROC NOT READY			Setting error	(1)Turn the power OFF then back ON. (2)If the alarm occurs again, replace the controller. Save the CMOS.BIN before replacement to be safe.
				Main CPU board failure	(1)Turn the power OFF then back ON. (2)If the alarm occurs again, replace the controller. Save the CMOS.BIN before replacement to be safe.
510	SOFTWARE VERSION UNMATCH	50	1st Servo control board's interface version is not corresponding to Main CPU board	Main CPU board failure	(1)Turn the power OFF then back ON. (2)If the alarm occurs again, replace the controller. Save the CMOS.BIN before replacement to be safe.
		51	2nd Servo control board's interface version is not corresponding to Main CPU board.	Main CPU board failure	(1)Turn the power OFF then back ON. (2)If the alarm occurs again, replace the controller. Save the CMOS.BIN before replacement to be safe.
520	AXIS LIMIT OVER	0		Setting error	(1)Check the following settings. -Control group settings in maintenance mode
				Main CPU board failure	(1)Turn the power OFF then back ON. (2)If the alarm occurs again, replace the controller. Save the CMOS.BIN before replacement to be safe.
710	LADDER INITIALIZE ERROR			Data error	(1)Turn the power OFF then back ON. (2)If the alarm occurs again, initialize the appropriate data in maintenance mode, and then load the data saved in the external memory device.
				Main CPU board failure	(1)Turn the power OFF then back ON. (2)If the alarm occurs again, replace the controller. Save the CMOS.BIN before replacement to be safe.
720	LADDER PROGRAM ERROR	1	An error was found in the relay No. specification.	Data error	(1)Turn the power OFF then back ON. (2)If the alarm occurs again, initialize the appropriate data in maintenance mode, and then load the data saved in the external memory device.
				Main CPU board failure	(1)Turn the power OFF then back ON. (2)If the alarm occurs again, replace the controller. Save the CMOS.BIN before replacement to be safe.

Alarm Number	Alarm Name	Sub Code	Meaning	Cause	Remedy
		2	An error was found in the register No. specification.	Data error	(1)Turn the power OFF then back ON. (2)If the alarm occurs again, initialize the appropriate data in maintenance mode, and then load the data saved in the external memory device.
				Main CPU board failure	(1)Turn the power OFF then back ON. (2)If the alarm occurs again, replace the controller. Save the CMOS.BIN before replacement to be safe.
		3	An incorrect instruction was set.	Data error	(1)Turn the power OFF then back ON. (2)If the alarm occurs again, initialize the appropriate data in maintenance mode, and then load the data saved in the external memory device.
				Main CPU board failure	(1)Turn the power OFF then back ON. (2)If the alarm occurs again, replace the controller. Save the CMOS.BIN before replacement to be safe.
		4	Output register is used redundantly.	Data error	(1)Turn the power OFF then back ON. (2)If the alarm occurs again, initialize the appropriate data in maintenance mode, and then load the data saved in the external memory device.
				Main CPU board failure	(1)Turn the power OFF then back ON. (2)If the alarm occurs again, replace the controller. Save the CMOS.BIN before replacement to be safe.
		5	Output relay is used redundantly.	Data error	(1)Turn the power OFF then back ON. (2)If the alarm occurs again, initialize the appropriate data in maintenance mode, and then load the data saved in the external memory device.
				Main CPU board failure	(1)Turn the power OFF then back ON. (2)If the alarm occurs again, replace the controller. Save the CMOS.BIN before replacement to be safe.
		6	Unconnected relay exists.	Data error	(1)Turn the power OFF then back ON. (2)If the alarm occurs again, initialize the appropriate data in maintenance mode, and then load the data saved in the external memory device.
				Main CPU board failure	(1)Turn the power OFF then back ON. (2)If the alarm occurs again, replace the controller. Save the CMOS.BIN before replacement to be safe.
		7	The STR instructions are overused.	Data error	(1)Turn the power OFF then back ON. (2)If the alarm occurs again, initialize the appropriate data in maintenance mode, and then load the data saved in the external memory device.
				Main CPU board failure	(1)Turn the power OFF then back ON. (2)If the alarm occurs again, replace the controller. Save the CMOS.BIN before replacement to be safe.

Alarm Number	Alarm Name	Sub Code	Meaning	Cause	Remedy
		8	The AND-STR instructions are overused.	Data error	(1)Turn the power OFF then back ON. (2)If the alarm occurs again, initialize the appropriate data in maintenance mode, and then load the data saved in the external memory device.
				Main CPU board failure	(1)Turn the power OFF then back ON. (2)If the alarm occurs again, replace the controller. Save the CMOS.BIN before replacement to be safe.
		9	A syntax error was found in the CNT instruction.	Data error	(1)Turn the power OFF then back ON. (2)If the alarm occurs again, initialize the appropriate data in maintenance mode, and then load the data saved in the external memory device.
				Main CPU board failure	(1)Turn the power OFF then back ON. (2)If the alarm occurs again, replace the controller. Save the CMOS.BIN before replacement to be safe.
		10	The head of the block starts with an instruction other than the STR instruction.	Data error	(1)Turn the power OFF then back ON. (2)If the alarm occurs again, initialize the appropriate data in maintenance mode, and then load the data saved in the external memory device.
				Main CPU board failure	(1)Turn the power OFF then back ON. (2)If the alarm occurs again, replace the controller. Save the CMOS.BIN before replacement to be safe.
		11	Excessive machine codes	Data error	(1)Turn the power OFF then back ON. (2)If the alarm occurs again, initialize the appropriate data in maintenance mode, and then load the data saved in the external memory device.
				Main CPU board failure	(1)Turn the power OFF then back ON. (2)If the alarm occurs again, replace the controller. Save the CMOS.BIN before replacement to be safe.
		12	The last instruction is not the END instruction.	Data error	(1)Turn the power OFF then back ON. (2)If the alarm occurs again, initialize the appropriate data in maintenance mode, and then load the data saved in the external memory device.
				Main CPU board failure	(1)Turn the power OFF then back ON. (2)If the alarm occurs again, replace the controller. Save the CMOS.BIN before replacement to be safe.
		13	An error was found in the PART instruction.	Data error	(1)Turn the power OFF then back ON. (2)If the alarm occurs again, initialize the appropriate data in maintenance mode, and then load the data saved in the external memory device.
				Main CPU board failure	(1)Turn the power OFF then back ON. (2)If the alarm occurs again, replace the controller. Save the CMOS.BIN before replacement to be safe.

Alarm Number	Alarm Name	Sub Code	Meaning	Cause	Remedy
		14	An error was found in the GOUT instruction.	Data error	(1)Turn the power OFF then back ON. (2)If the alarm occurs again, initialize the appropriate data in maintenance mode, and then load the data saved in the external memory device.
				Main CPU board failure	(1)Turn the power OFF then back ON. (2)If the alarm occurs again, replace the controller. Save the CMOS.BIN before replacement to be safe.
		15	The No. of operand is incorrect.	Data error	(1)Turn the power OFF then back ON. (2)If the alarm occurs again, initialize the appropriate data in maintenance mode, and then load the data saved in the external memory device.
				Main CPU board failure	(1)Turn the power OFF then back ON. (2)If the alarm occurs again, replace the controller. Save the CMOS.BIN before replacement to be safe.
		16	The constant value is incorrect.	Data error	(1)Turn the power OFF then back ON. (2)If the alarm occurs again, initialize the appropriate data in maintenance mode, and then load the data saved in the external memory device.
				Main CPU board failure	(1)Turn the power OFF then back ON. (2)If the alarm occurs again, replace the controller. Save the CMOS.BIN before replacement to be safe.
		17	The step capacity exceeds the memory capacity.	Data error	(1)Turn the power OFF then back ON. (2)If the alarm occurs again, initialize the appropriate data in maintenance mode, and then load the data saved in the external memory device.
				Main CPU board failure	(1)Turn the power OFF then back ON. (2)If the alarm occurs again, replace the controller. Save the CMOS.BIN before replacement to be safe.
		18	The number of operation instructions exceed the permissible value.	Data error	(1)Turn the power OFF then back ON. (2)If the alarm occurs again, initialize the appropriate data in maintenance mode, and then load the data saved in the external memory device.
				Main CPU board failure	(1)Turn the power OFF then back ON. (2)If the alarm occurs again, replace the controller. Save the CMOS.BIN before replacement to be safe.
		19	A syntax error was found in the CNT instruction or TMR instruction.	Data error	(1)Turn the power OFF then back ON. (2)If the alarm occurs again, initialize the appropriate data in maintenance mode, and then load the data saved in the external memory device.
				Main CPU board failure	(1)Turn the power OFF then back ON. (2)If the alarm occurs again, replace the controller. Save the CMOS.BIN before replacement to be safe.

Alarm Number	Alarm Name	Sub Code	Meaning	Cause	Remedy
		20	A syntax error was found in the JMP-LABEL instructions.	Data error	(1)Turn the power OFF then back ON. (2)If the alarm occurs again, initialize the appropriate data in maintenance mode, and then load the data saved in the external memory device.
				Main CPU board failure	(1)Turn the power OFF then back ON. (2)If the alarm occurs again, replace the controller. Save the CMOS.BIN before replacement to be safe.
		21	The label of JMP destination does not exist.	Data error	(1)Turn the power OFF then back ON. (2)If the alarm occurs again, initialize the appropriate data in maintenance mode, and then load the data saved in the external memory device.
				Main CPU board failure	(1)Turn the power OFF then back ON. (2)If the alarm occurs again, replace the controller. Save the CMOS.BIN before replacement to be safe.
790	MEMORY BATTERY WEAK		Main CPU board battery is weakening.	Connection failure	(1)Confirm that the battery is appropriately connected to the main CPU board.
				Connection failure	(1)Replace the battery in accordance with the instructions in FS100 MAINTENANCE MANUAL.
820	CNTR01R HARDWARE ERROR		Sub Code: Option board. Number × 100 factor factor: 1 ROM ERR 2 RAM ERR 3 CPU ERR 4 SHARED MEMORY ERR 5 CNTR ASIC ERR	CNTR01R board failure	(1)Turn the power OFF then back ON. (2)If the alarm occurs again, replace the CNTR01R board. Save the CMOS.BIN before replacing the board to be safe.
821	CNTR01R SOFTWARE ERROR		Sub Code: Option board. Number×100 factor factor: 1 WDG TIMEOVER 2 ADDRESS ERR(READ) EXCEPTION 3 ADDRESS ERR(WRITE) EXCEPTION 4 UNJUST INST EXCEPTION 5 UNJUST SLOT EXCEPTION	CNTR01R board failure	(1)Turn the power OFF then back ON. (2)If the alarm occurs again, replace the CNTR01R board. Save the CMOS.BIN before replacing the board to be safe.
822	CNTR01R WDG ERROR	100	A Watchdog err was detected in the Option #1 board.	CNTR01R board failure	(1)Turn the power OFF then back ON. (2)If the alarm occurs again, replace the CNTR01R board. Save the CMOS.BIN before replacing the board to be safe.

Alarm Number	Alarm Name	Sub Code	Meaning	Cause	Remedy
		200	A Watchdog err was detected in the Option #2 board.	CNTR01R board failure	(1)Turn the power OFF then back ON. (2)If the alarm occurs again, replace the CNTR01R board. Save the CMOS.BIN before replacing the board to be safe.
		300	A Watchdog err was detected in the Option #3 board.	CNTR01R board failure	(1)Turn the power OFF then back ON. (2)If the alarm occurs again, replace the CNTR01R board. Save the CMOS.BIN before replacing the board to be safe.
		400	A Watchdog err was detected in the Option #4 board.	CNTR01R board failure	(1)Turn the power OFF then back ON. (2)If the alarm occurs again, replace the CNTR01R board. Save the CMOS.BIN before replacing the board to be safe.
		500	A Watchdog err was detected in the Option #5 board.	CNTR01R board failure	(1)Turn the power OFF then back ON. (2)If the alarm occurs again, replace the CNTR01R board. Save the CMOS.BIN before replacing the board to be safe.
		600	A Watchdog err was detected in the Option #6 board.	CNTR01R board failure	(1)Turn the power OFF then back ON. (2)If the alarm occurs again, replace the CNTR01R board. Save the CMOS.BIN before replacing the board to be safe.
		700	A Watchdog err was detected in the Option #7 board.	CNTR01R board failure	(1)Turn the power OFF then back ON. (2)If the alarm occurs again, replace the CNTR01R board. Save the CMOS.BIN before replacing the board to be safe.
		800	A Watchdog err was detected in the Option #8 board.	CNTR01R board failure	(1)Turn the power OFF then back ON. (2)If the alarm occurs again, replace the CNTR01R board. Save the CMOS.BIN before replacing the board to be safe.
910	CPU ERROR (CPU-201R)	1	An error was detected in the CPU.	Main CPU board failure	(1)Turn the power OFF then back ON. (2)If the alarm occurs again, replace the controller. Save the CMOS.BIN before replacement to be safe.
920	BUS ERROR (CPU-201R)	1	The JL chip does not operate normally.	Main CPU board failure	(1)Turn the power OFF then back ON. (2)If the alarm occurs again, replace the controller. Save the CMOS.BIN before replacement to be safe.
950	CPU ERROR (servo#1)		An error was detected in the CPU of servo board #1.	Connection failure	(1)Turn the power OFF then back ON. (2)If the alarm occurs again, replace the controller. Save the CMOS.BIN before replacement to be safe.
				Servo control board failure	(1)Turn the power OFF then back ON. (2)If the alarm occurs again, replace the controller. Save the CMOS.BIN before replacement to be safe.
				Main CPU board failure	(1)Turn the power OFF then back ON. (2)If the alarm occurs again, replace the controller. Save the CMOS.BIN before replacement to be safe.

Alarm Number	Alarm Name	Sub Code	Meaning	Cause	Remedy
951	CPU ERROR (servo#2)		An error was detected in the CPU of servo board #2.	Connection failure	(1)Turn the power OFF then back ON. (2)If the alarm occurs again, replace the controller. Save the CMOS.BIN before replacement to be safe.
				Servo control board failure	(1)Turn the power OFF then back ON. (2)If the alarm occurs again, replace the controller. Save the CMOS.BIN before replacement to be safe.
				Main CPU board failure	(1)Turn the power OFF then back ON. (2)If the alarm occurs again, replace the controller. Save the CMOS.BIN before replacement to be safe.
990	SYSTEM ERROR (Main CPU)	1	Power Lost Signal Error	Main CPU board failure	(1)Turn the power OFF then back ON. (2)If the alarm occurs again, replace the controller. Save the CMOS.BIN before replacement to be safe.
1000	ROM ERROR (Main CPU)			Software operation error occurred	(1)Turn the power OFF then back ON. (2)If the alarm occurs again, save the CMOS.BIN in maintenance mode, and then contact your Yaskawa representative about occurrence status (operating procedure).
1001	ROM ERROR (SERVO)	10	1*:A checksum error occurred in the board or the EEPROM. (*: axis No.)	Servo control board failure	(1)Turn the power OFF then back ON. (2)If the alarm occurs again, replace controller. Save the CMOS.BIN before replace controller to be safe.
		20	The SRDY signal did not turn ON after the WRITE ENABLE command was written. (EEPROM WRITE ENABLE error)	Servo control board failure	(1)Turn the power OFF then back ON. (2)If the alarm occurs again, replace controller. Save the CMOS.BIN before replace controller to be safe.
		21	The SRDY signal did not turn ON after the WRITE PROTECT command was written. (EEPROM WRITE PROTECT error)	Servo control board failure	(1)Turn the power OFF then back ON. (2)If the alarm occurs again, replace controller. Save the CMOS.BIN before replace controller to be safe.
		22	The SRDY signal did not turn ON after the ERASE command was written. (EEPROM ERASE error)	Servo control board failure	(1)Turn the power OFF then back ON. (2)If the alarm occurs again, replace controller. Save the CMOS.BIN before replace controller to be safe.
		23	The SRDY signal did not turn ON after the CLEAR command was written. (EEPROM CLEAR error)	Servo control board failure	(1)Turn the power OFF then back ON. (2)If the alarm occurs again, replace controller. Save the CMOS.BIN before replace controller to be safe.
		24	The SRDY signal did not turn ON after data were written. (EEPROM writing error)	Servo control board failure	(1)Turn the power OFF then back ON. (2)If the alarm occurs again, replace controller. Save the CMOS.BIN before replace controller to be safe.

Alarm Number	Alarm Name	Sub Code	Meaning	Cause	Remedy
		25	The SRDY signal did not turn ON after data were read. (EEPROM reading error)	Servo control board failure	(1)Turn the power OFF then back ON. (2)If the alarm occurs again, replace controller. Save the CMOS.BIN before replace controller to be safe.
		26	The written data were rejected at verification. (EEPROM verify error)	Servo control board failure	(1)Turn the power OFF then back ON. (2)If the alarm occurs again, replace controller. Save the CMOS.BIN before replace controller to be safe.
1020	MotoPlus application load error	1	Num of the Application files is over the limit.	Setting error	Set the number of application file "*.OUT" to be within the defined value. (Delete unnecessary files from the MotoPlus menu of the maintenance mode.)
		2	Insufficient memory space	Setting error	Memory to work MotoPlus application is insufficient under the combination of current system configuration and its optional function. If the alarm occurs again, save the CMOS.BIN in maintenance mode, and then contact your Yaskawa representative about occurrence status (operating procedure).
		3	MotoPlus application folder cannot be found.	Setting error	(1)Turn the power OFF then back ON. (2)If the alarm occurs again, replace controller and load the MotoPlus application which was loaded to the previous controller.
		4	Memory size required by Application is over the limit (2Mbyte).	Setting error	Check that if the object file name is too long or inappropriate letters are used.
		5	Undefined symbols are included in the application.	Setting error	Check that symbols such as undefined functions or constants, which are provided from the system side, are included in the application program.
		6	Load failure (other)	Setting error	(1)Check the definition of static variable in the MotoPlus application program is correct or not. (2)Check the MotoPlus application programs so that they are set within the specified values. (3)Check that the object files are appropriately created.
		7	API library initialization failure	Setting error	Memory to work MotoPlus application is insufficient under the combination of current system configuration and its optional function. If the alarm occurs again, save the CMOS.BIN in maintenance mode, and then contact your Yaskawa representative about occurrence status (operating procedure).
		8	User root task not included	Setting error	Confirm that mpUsRoot() is described in the application program.
		9	User root task generation failure	Setting error	Memory to work MotoPlus application is insufficient under the combination of current system configuration and its optional function. If the alarm occurs again, save the CMOS.BIN in maintenance mode, and then contact your Yaskawa representative about occurrence status (operating procedure).

Alarm Number	Alarm Name	Sub Code	Meaning	Cause	Remedy
		10	RAM-Disk generation failure	Setting error	Memory to work MotoPlus application is insufficient under the combination of current system configuration and its optional function. If the alarm occurs again, save the CMOS.BIN in maintenance mode, and then contact your Yaskawa representative about occurrence status (operating procedure).
		11	MotoPlus application process generation failure	Setting error	Check that the object file is appropriately created.
		12	application file "*.VXE" in the controller exceeded the specified value	Setting error	Set the number of application file "*.VXE" to be within the defined value. (Delete unnecessary files from the MotoPlus menu of the maintenance mode.)
		13	Failure to install the driver to communicate between MotoPlus application and the system.	Setting error	Memory to work MotoPlus application is insufficient under the combination of current system configuration and its optional function. If the alarm occurs again, save the CMOS.BIN in maintenance mode, and then contact your Yaskawa representative about occurrence status (operating procedure).
1030	MEMORY ERROR (PARAMETER FILE)	0	RCD, RCxG parameter error	Data error	(1)Turn the power OFF then back ON. (2)If the alarm occurs again, initialize the appropriate parameter file in maintenance mode, and then load the parameter file saved in the external memory device.
				Main CPU board failure	(1)Turn the power OFF then back ON. (2)If the alarm occurs again, replace controller. Save the CMOS.BIN before replace controller to be safe.
		1	ROxG parameter error	Data error	(1)Turn the power OFF then back ON. (2)If the alarm occurs again, initialize the appropriate parameter file in maintenance mode, and then load the parameter file saved in the external memory device.
				Main CPU board failure	(1)Turn the power OFF then back ON. (2)If the alarm occurs again, replace controller. Save the CMOS.BIN before replace controller to be safe.
		2	SVD, SVxG parameter error	Data error	(1)Turn the power OFF then back ON. (2)If the alarm occurs again, initialize the appropriate parameter file in maintenance mode, and then load the parameter file saved in the external memory device.
				Main CPU board failure	(1)Turn the power OFF then back ON. (2)If the alarm occurs again, replace controller. Save the CMOS.BIN before replace controller to be safe.
		3	SVMxG parameter error	Data error	(1)Turn the power OFF then back ON. (2)If the alarm occurs again, initialize the appropriate parameter file in maintenance mode, and then load the parameter file saved in the external memory device.

Alarm Number	Alarm Name	Sub Code	Meaning	Cause	Remedy
				Main CPU board failure	(1)Turn the power OFF then back ON. (2)If the alarm occurs again, replace controller. Save the CMOS.BIN before replace controller to be safe.
		4	S1CxG, S2C, S3C, S4C parameter error	Data error	(1)Turn the power OFF then back ON. (2)If the alarm occurs again, initialize the appropriate parameter file in maintenance mode, and then load the parameter file saved in the external memory device.
				Main CPU board failure	(1)Turn the power OFF then back ON. (2)If the alarm occurs again, replace controller. Save the CMOS.BIN before replace controller to be safe.
		5	S1D, S2D, S3D, S4D parameter error	Data error	(1)Turn the power OFF then back ON. (2)If the alarm occurs again, initialize the appropriate parameter file in maintenance mode, and then load the parameter file saved in the external memory device.
				Main CPU board failure	(1)Turn the power OFF then back ON. (2)If the alarm occurs again, replace controller. Save the CMOS.BIN before replace controller to be safe.
		6	CIO parameter error	Data error	(1)Turn the power OFF then back ON. (2)If the alarm occurs again, initialize the appropriate parameter file in maintenance mode, and then load the parameter file saved in the external memory device.
				Main CPU board failure	(1)Turn the power OFF then back ON. (2)If the alarm occurs again, replace controller. Save the CMOS.BIN before replace controller to be safe.
		7	FD parameter error	Data error	(1)Turn the power OFF then back ON. (2)If the alarm occurs again, initialize the appropriate parameter file in maintenance mode, and then load the parameter file saved in the external memory device.
				Main CPU board failure	(1)Turn the power OFF then back ON. (2)If the alarm occurs again, replace controller. Save the CMOS.BIN before replace controller to be safe.
		8	A1P, A2P, ..., A8P parameter error	Data error	(1)Turn the power OFF then back ON. (2)If the alarm occurs again, initialize the appropriate parameter file in maintenance mode, and then load the parameter file saved in the external memory device.
				Main CPU board failure	(1)Turn the power OFF then back ON. (2)If the alarm occurs again, replace controller. Save the CMOS.BIN before replace controller to be safe.

Alarm Number	Alarm Name	Sub Code	Meaning	Cause	Remedy
		9	RS parameter error	Data error	(1)Turn the power OFF then back ON. (2)If the alarm occurs again, initialize the appropriate parameter file in maintenance mode, and then load the parameter file saved in the external memory device.
				Main CPU board failure	(1)Turn the power OFF then back ON. (2)If the alarm occurs again, replace controller. Save the CMOS.BIN before replace controller to be safe.
		10	S1E, S2E, ..., S8E parameter error	Data error	(1)Turn the power OFF then back ON. (2)If the alarm occurs again, initialize the appropriate parameter file in maintenance mode, and then load the parameter file saved in the external memory device.
				Main CPU board failure	(1)Turn the power OFF then back ON. (2)If the alarm occurs again, replace controller. Save the CMOS.BIN before replace controller to be safe.
		11	SVCxB parameter error	Data error	(1)Turn the power OFF then back ON. (2)If the alarm occurs again, initialize the appropriate parameter file in maintenance mode, and then load the parameter file saved in the external memory device.
				Main CPU board failure	(1)Turn the power OFF then back ON. (2)If the alarm occurs again, replace controller. Save the CMOS.BIN before replace controller to be safe.
		12	AMCxG parameter error	Data error	(1)Turn the power OFF then back ON. (2)If the alarm occurs again, initialize the appropriate parameter file in maintenance mode, and then load the parameter file saved in the external memory device.
				Main CPU board failure	(1)Turn the power OFF then back ON. (2)If the alarm occurs again, replace controller. Save the CMOS.BIN before replace controller to be safe.
		13	SVPxG parameter error	Data error	(1)Turn the power OFF then back ON. (2)If the alarm occurs again, initialize the appropriate parameter file in maintenance mode, and then load the parameter file saved in the external memory device.
				Main CPU board failure	(1)Turn the power OFF then back ON. (2)If the alarm occurs again, replace controller. Save the CMOS.BIN before replace controller to be safe.

Alarm Number	Alarm Name	Sub Code	Meaning	Cause	Remedy
		14	MFxG parameter error	Data error	(1)Turn the power OFF then back ON. (2)If the alarm occurs again, initialize the appropriate parameter file in maintenance mode, and then load the parameter file saved in the external memory device.
				Main CPU board failure	(1)Turn the power OFF then back ON. (2)If the alarm occurs again, replace controller. Save the CMOS.BIN before replace controller to be safe.
		15	SVSxG parameter error	Data error	(1)Turn the power OFF then back ON. (2)If the alarm occurs again, initialize the appropriate parameter file in maintenance mode, and then load the parameter file saved in the external memory device.
				Main CPU board failure	(1)Turn the power OFF then back ON. (2)If the alarm occurs again, replace controller. Save the CMOS.BIN before replace controller to be safe.
		16	RExG parameter error	Data error	(1)Turn the power OFF then back ON. (2)If the alarm occurs again, initialize the appropriate parameter file in maintenance mode, and then load the parameter file saved in the external memory device.
				Main CPU board failure	(1)Turn the power OFF then back ON. (2)If the alarm occurs again, replace controller. Save the CMOS.BIN before replace controller to be safe.
1031	MEMORY ERROR (MOTION1)	0	"GET FILE" instruction, "SET FILE" instruction execution target file	Data error	(1)Turn the power OFF then back ON. (2)If the alarm occurs again, initialize the appropriate data in maintenance mode, and then load the data saved in the external memory device.
		1	Home position calibration file	Data error	(1)Turn the power OFF then back ON. (2)If the alarm occurs again, initialize the appropriate data in maintenance mode, and then load the data saved in the external memory device.
		2	Tool file	Data error	(1)Turn the power OFF then back ON. (2)If the alarm occurs again, initialize the appropriate data in maintenance mode, and then load the data saved in the external memory device.
		3	User coordinates file	Data error	(1)Turn the power OFF then back ON. (2)If the alarm occurs again, initialize the appropriate data in maintenance mode, and then load the data saved in the external memory device.
		4	Robot calibration file	Data error	(1)Turn the power OFF then back ON. (2)If the alarm occurs again, initialize the appropriate data in maintenance mode, and then load the data saved in the external memory device.

Alarm Number	Alarm Name	Sub Code	Meaning	Cause	Remedy
		5	Tool calibration file	Data error	(1)Turn the power OFF then back ON. (2)If the alarm occurs again, initialize the appropriate data in maintenance mode, and then load the data saved in the external memory device.
		7	Home position correction data file	Data error	(1)Turn the power OFF then back ON. (2)If the alarm occurs again, initialize the appropriate data in maintenance mode, and then load the data saved in the external memory device.
		8	Conveyor calibration file	Data error	(1)Turn the power OFF then back ON. (2)If the alarm occurs again, initialize the appropriate data in maintenance mode, and then load the data saved in the external memory device.
		9	Arm and tool interference prevention file	Data error	(1)Turn the power OFF then back ON. (2)If the alarm occurs again, initialize the appropriate data in maintenance mode, and then load the data saved in the external memory device.
		34	Conveyor condition file	Data error	(1)Turn the power OFF then back ON. (2)If the alarm occurs again, initialize the appropriate data in maintenance mode, and then load the data saved in the external memory device.
		35	Press characteristics file	Data error	(1)Turn the power OFF then back ON. (2)If the alarm occurs again, initialize the appropriate data in maintenance mode, and then load the data saved in the external memory device.
		36	Servo float condition file	Data error	(1)Turn the power OFF then back ON. (2)If the alarm occurs again, initialize the appropriate data in maintenance mode, and then load the data saved in the external memory device.
		42	Anticipation OT# output file	Data error	(1)Turn the power OFF then back ON. (2)If the alarm occurs again, initialize the appropriate data in maintenance mode, and then load the data saved in the external memory device.
		43	Anticipation OG# output file	Data error	(1)Turn the power OFF then back ON. (2)If the alarm occurs again, initialize the appropriate data in maintenance mode, and then load the data saved in the external memory device.
		45	Form cut file	Data error	(1)Turn the power OFF then back ON. (2)If the alarm occurs again, initialize the appropriate data in maintenance mode, and then load the data saved in the external memory device.
		47	Linear servo float condition file	Data error	(1)Turn the power OFF then back ON. (2)If the alarm occurs again, initialize the appropriate data in maintenance mode, and then load the data saved in the external memory device.
		48	Macro definition file	Data error	(1)Turn the power OFF then back ON. (2)If the alarm occurs again, initialize the appropriate data in maintenance mode, and then load the data saved in the external memory device.

Alarm Number	Alarm Name	Sub Code	Meaning	Cause	Remedy
		53	Job registration table	Data error	(1)Turn the power OFF then back ON. (2)If the alarm occurs again, initialize the appropriate data in maintenance mode, and then load the data saved in the external memory device.
		62	Linear scale condition file	Data error	(1)Turn the power OFF then back ON. (2)If the alarm occurs again, initialize the appropriate data in maintenance mode, and then load the data saved in the external memory device.
		64	Conveyor condition auxiliary file	Data error	(1)Turn the power OFF then back ON. (2)If the alarm occurs again, initialize the appropriate data in maintenance mode, and then load the data saved in the external memory device.
		67	Pelletizing condition file	Data error	(1)Turn the power OFF then back ON. (2)If the alarm occurs again, initialize the appropriate data in maintenance mode, and then load the data saved in the external memory device.
		69	Mastering registration position	Data error	(1)Turn the power OFF then back ON. (2)If the alarm occurs again, initialize the appropriate data in maintenance mode, and then load the data saved in the external memory device.
1050	SET-UP PROCESS ERROR (SYSCON)	1	Motion instruction setup incomplete	Main CPU board failure	(1)Turn the power OFF then back ON. (2)If the alarm occurs again, replace controller. Save the CMOS.BIN before replace controller to be safe.
				Software operation error occurred	(1)Turn the power OFF then back ON. (2)If the alarm occurs again, save the CMOS.BIN in maintenance mode, and then contact your Yaskawa representative about occurrence status (operating procedure).
		2	Online error	Main CPU board failure	(1)Turn the power OFF then back ON. (2)If the alarm occurs again, replace controller. Save the CMOS.BIN before replace controller to be safe.
				Software operation error occurred	(1)Turn the power OFF then back ON. (2)If the alarm occurs again, save the CMOS.BIN in maintenance mode, and then contact your Yaskawa representative about occurrence status (operating procedure).
1051	SET-UP PROCESS ERROR (MOTION)	1	Unable to properly activate the servo control	Servo control board failure	(1)Turn the power OFF then back ON. (2)If the alarm occurs again, replace controller. Save the CMOS.BIN before replace controller to be safe.
				Software operation error occurred	(1)Turn the power OFF then back ON. (2)If the alarm occurs again, save the CMOS.BIN in maintenance mode, and then contact your Yaskawa representative about occurrence status (operating procedure).

Alarm Number	Alarm Name	Sub Code	Meaning	Cause	Remedy
		2	The position data of when the power supply was turned OFF cannot be transmitted to the servo control section	Servo control board failure	(1)Turn the power OFF then back ON. (2)If the alarm occurs again, replace controller. Save the CMOS.BIN before replace controller to be safe.
				Software operation error occurred	(1)Turn the power OFF then back ON. (2)If the alarm occurs again, save the CMOS.BIN in maintenance mode, and then contact your Yaskawa representative about occurrence status (operating procedure).
		3	The servo control section cannot receive the position data of when the power supply was turned OFF	Servo control board failure	(1)Turn the power OFF then back ON. (2)If the alarm occurs again, replace controller. Save the CMOS.BIN before replace controller to be safe.
				Software operation error occurred	(1)Turn the power OFF then back ON. (2)If the alarm occurs again, save the CMOS.BIN in maintenance mode, and then contact your Yaskawa representative about occurrence status (operating procedure).
		7	Unable to send a request to prepare a feedback pulse	Servo control board failure	(1)Turn the power OFF then back ON. (2)If the alarm occurs again, replace controller. Save the CMOS.BIN before replace controller to be safe.
				Software operation error occurred	(1)Turn the power OFF then back ON. (2)If the alarm occurs again, save the CMOS.BIN in maintenance mode, and then contact your Yaskawa representative about occurrence status (operating procedure).
		8	Unable to prepare a feedback pulse	Servo control board failure	(1)Turn the power OFF then back ON. (2)If the alarm occurs again, replace controller. Save the CMOS.BIN before replace controller to be safe.
				Software operation error occurred	(1)Turn the power OFF then back ON. (2)If the alarm occurs again, save the CMOS.BIN in maintenance mode, and then contact your Yaskawa representative about occurrence status (operating procedure).
		9	Unable to send a request to initialize the arithmetic section (ARITH)	Main CPU board failure	(1)Turn the power OFF then back ON. (2)If the alarm occurs again, replace controller. Save the CMOS.BIN before replace controller to be safe.
				Software operation error occurred	(1)Turn the power OFF then back ON. (2)If the alarm occurs again, save the CMOS.BIN in maintenance mode, and then contact your Yaskawa representative about occurrence status (operating procedure).

Alarm Number	Alarm Name	Sub Code	Meaning	Cause	Remedy
		10	Unable to initialize ARITH	Main CPU board failure	(1)Turn the power OFF then back ON. (2)If the alarm occurs again, replace controller. Save the CMOS.BIN before replace controller to be safe.
				Software operation error occurred	(1)Turn the power OFF then back ON. (2)If the alarm occurs again, save the CMOS.BIN in maintenance mode, and then contact your Yaskawa representative about occurrence status (operating procedure).
		11	Unable to send a request to prepare the current position	Main CPU board failure	(1)Turn the power OFF then back ON. (2)If the alarm occurs again, replace controller. Save the CMOS.BIN before replace controller to be safe.
				Software operation error occurred	(1)Turn the power OFF then back ON. (2)If the alarm occurs again, save the CMOS.BIN in maintenance mode, and then contact your Yaskawa representative about occurrence status (operating procedure).
		12	Unable to prepare the current position	Main CPU board failure	(1)Turn the power OFF then back ON. (2)If the alarm occurs again, replace controller. Save the CMOS.BIN before replace controller to be safe.
				Software operation error occurred	(1)Turn the power OFF then back ON. (2)If the alarm occurs again, save the CMOS.BIN in maintenance mode, and then contact your Yaskawa representative about occurrence status (operating procedure).
1053	SYSTEM ERROR (EVENT)		Sub Code 1 to 8: Signifies the internal software error at event process.	Software operation error occurred	(1)Turn the power OFF then back ON. (2)If the alarm occurs again, save the CMOS.BIN in maintenance mode, and then contact your Yaskawa representative about occurrence status (operating procedure).
1100	SYSTEM ERROR		Sub Code C, B, F : Sub code of unknown alarm	Software operation error occurred	(1)Turn the power OFF then back ON. (2)If the alarm occurs again, save the CMOS.BIN in maintenance mode, and then contact your Yaskawa representative about occurrence status (operating procedure).
				RAM software data error	(1)Turn the power OFF then back ON. (2)If the alarm occurs again, save the CMOS.BIN in maintenance mode, and then contact your Yaskawa representative about occurrence status (operating procedure).
1101	SYSTEM ERROR (MAN-MACHINE MECHA)		Sub Code 0 to 6: Internal control error in software	Software operation error occurred	(1)Turn the power OFF then back ON. (2)If the alarm occurs again, save the CMOS.BIN in maintenance mode, and then contact your Yaskawa representative about occurrence status (operating procedure).

Alarm Number	Alarm Name	Sub Code	Meaning	Cause	Remedy
1102	SYSTEM ERROR (MAN-MACHINE APPLI)		Sub Code 0 to 526: Internal control error in software	Software operation error occurred	(1)Turn the power OFF then back ON. (2)If the alarm occurs again, save the CMOS.BIN in maintenance mode, and then contact your Yaskawa representative about occurrence status (operating procedure).
1103	SYSTEM ERROR (EVENT)			Software operation error occurred	(1)Turn the power OFF then back ON. (2)If the alarm occurs again, save the CMOS.BIN in maintenance mode, and then contact your Yaskawa representative about occurrence status (operating procedure).
1104	SYSTEM ERROR (CIO)		Sub Code 1000_0000: I/O module setting error	Connection failure	(1)Turn the power OFF then back ON. (2)If the alarm occurs again, check the connecting or inserting state of the following cables or connectors. ·IO module cable of the corresponding slot. ·24V power of the corresponding IO module.
				Setting error	(1)Turn the power OFF then back ON. (2)If the error occurs again, set the I/O module again in maintenance mode. (3)If the alarm occurs again, save the CMOS.BIN in maintenance mode, and then contact your Yaskawa representative about occurrence status (operating procedure).
				Main CPU board failure	(1)Turn the power OFF then back ON. (2)If the alarm occurs again, replace the YCP01 board. Save the CMOS.BIN before replace the board to be safe. Replace the YCP01 board, and then remove the CF from the failure YCP01 board to insert it into the new YCP01.
1105	SYSTEM ERROR (SERVO)	15	Communication period with the motion part is inappropriate.	Software operation error occurred	(1)Turn the power OFF then back ON. (2)If the alarm occurs again, save the CMOS.BIN in maintenance mode, and then contact your Yaskawa representative about occurrence status (operating procedure).
				Servo control board failure	(1)Turn the power OFF then back ON. (2)If the alarm occurs again, replace controller. Save the CMOS.BIN before replace controller to be safe.
		21	A task request was sent to an axis in the alarm status.	Software operation error occurred	(1)Turn the power OFF then back ON. (2)If the alarm occurs again, save the CMOS.BIN in maintenance mode, and then contact your Yaskawa representative about occurrence status (operating procedure).
				Servo control board failure	(1)Turn the power OFF then back ON. (2)If the alarm occurs again, replace controller. Save the CMOS.BIN before replace controller to be safe.

Alarm Number	Alarm Name	Sub Code	Meaning	Cause	Remedy
		30	The linear servo float does not support the manipulator type specified in the RC parameter at calculation for servo-float-related parameters.	Software operation error occurred	(1)Turn the power OFF then back ON. (2)If the alarm occurs again, save the CMOS.BIN in maintenance mode, and then contact your Yaskawa representative about occurrence status (operating procedure).
		37	The manipulator (B-axis) passed the singular point while the linear servo float was ON.	Setting error	(1)Check the following settings. Correct the job so that the manipulator (B-axis) does not pass the singular point while the linear servo float is ON.
		47	The alarm number is illegal.	Software operation error occurred	(1)Turn the power OFF then back ON. (2)If the alarm occurs again, save the CMOS.BIN in maintenance mode, and then contact your Yaskawa representative about occurrence status (operating procedure).
		49	Parameter modified while the servo float is ON.	Setting error	(1)Turn the power OFF then back ON. (2)If the alarm occurs again, save the CMOS.BIN in maintenance mode, and then contact your Yaskawa representative about occurrence status (operating procedure).
		115	500 μ s non real process execution sequence error	Software operation error occurred	(1)Turn the power OFF then back ON. (2)If the alarm occurs again, save the CMOS.BIN in maintenance mode, and then contact your Yaskawa representative about occurrence status (operating procedure).
				Servo control board failure	(1)Turn the power OFF then back ON. (2)If the alarm occurs again, replace controller. Save the CMOS.BIN before replace controller to be safe.
		128	The dynamics calculation process did not complete within the time set on the scheduling table.	Software operation error occurred	(1)Turn the power OFF then back ON. (2)If the alarm occurs again, save the CMOS.BIN in maintenance mode, and then contact your Yaskawa representative about occurrence status (operating procedure).
				Servo control board failure	(1)Turn the power OFF then back ON. (2)If the alarm occurs again, replace controller. Save the CMOS.BIN before replace controller to be safe.
		135	General08ms process dose not complete within the time set by the scheduling table.	Software operation error occurred	(1)Turn the power OFF then back ON. (2)If the alarm occurs again, save the CMOS.BIN in maintenance mode, and then contact your Yaskawa representative about occurrence status (operating procedure).
				Servo control board failure	(1)Turn the power OFF then back ON. (2)If the alarm occurs again, replace controller. Save the CMOS.BIN before replace controller to be safe.

Alarm Number	Alarm Name	Sub Code	Meaning	Cause	Remedy
		136	Dynamics arithmetic process dose not complete within the time set by the scheduling table.	Software operation error occurred	(1)Turn the power OFF then back ON. (2)If the alarm occurs again, save the CMOS.BIN in maintenance mode, and then contact your Yaskawa representative about occurrence status (operating procedure).
				Servo control board failure	(1)Turn the power OFF then back ON. (2)If the alarm occurs again, replace controller. Save the CMOS.BIN before replace controller to be safe.
		137	500 μ s non real process dose not complete within the time set by the scheduling table.	Software operation error occurred	(1)Turn the power OFF then back ON. (2)If the alarm occurs again, save the CMOS.BIN in maintenance mode, and then contact your Yaskawa representative about occurrence status (operating procedure).
				Servo control board failure	(1)Turn the power OFF then back ON. (2)If the alarm occurs again, replace controller. Save the CMOS.BIN before replace controller to be safe.
		138	Real time process dose not complete within the time set by the scheduling table.	Software operation error occurred	(1)Turn the power OFF then back ON. (2)If the alarm occurs again, save the CMOS.BIN in maintenance mode, and then contact your Yaskawa representative about occurrence status (operating procedure).
				Servo control board failure	(1)Turn the power OFF then back ON. (2)If the alarm occurs again, replace controller. Save the CMOS.BIN before replace controller to be safe.
		140	External interruption occurred.	Software operation error occurred	(1)Turn the power OFF then back ON. (2)If the alarm occurs again, save the CMOS.BIN in maintenance mode, and then contact your Yaskawa representative about occurrence status (operating procedure).
				Servo control board failure	(1)Turn the power OFF then back ON. (2)If the alarm occurs again, replace controller. Save the CMOS.BIN before replace controller to be safe.
		151	The averaging time is not an even number. (times)	Software operation error occurred	(1)Turn the power OFF then back ON. (2)If the alarm occurs again, save the CMOS.BIN in maintenance mode, and then contact your Yaskawa representative about occurrence status (operating procedure).
		160	The interface with the microprogram dose not complete within the time set by the scheduling table.	Software operation error occurred	(1)Turn the power OFF then back ON. (2)If the alarm occurs again, save the CMOS.BIN in maintenance mode, and then contact your Yaskawa representative about occurrence status (operating procedure).

Alarm Number	Alarm Name	Sub Code	Meaning	Cause	Remedy
				Servo control board failure	(1)Turn the power OFF then back ON. (2)If the alarm occurs again, replace controller. Save the CMOS.BIN before replace controller to be safe.
		200	The notch filter doesn't become effective after shifting to PLAY mode.	Software operation error occurred	(1)Turn the power OFF then back ON. (2)If the alarm occurs again, save the CMOS.BIN in maintenance mode, and then contact your Yaskawa representative about occurrence status (operating procedure).
		303	The difference between the base torque and the target torque exceeded the threshold in the jig robot bending correction.	Software operation error occurred	(1)Turn the power OFF then back ON. (2)If the alarm occurs again, save the CMOS.BIN in maintenance mode, and then contact your Yaskawa representative about occurrence status (operating procedure).
		500	Inconsistency of FP register.	Servo control board failure	(1)Turn the power OFF then back ON. (2)If the alarm occurs again, replace controller. Save the CMOS.BIN before replace controller to be safe.
				Software operation error occurred	(1)Turn the power OFF then back ON. (2)If the alarm occurs again, save the CMOS.BIN in maintenance mode, and then contact your Yaskawa representative about occurrence status (operating procedure).
		1000	The check item number of SVD parameter is unmatched.	Software operation error occurred	(1)Turn the power OFF then back ON. (2)If the alarm occurs again, save the CMOS.BIN in maintenance mode, and then contact your Yaskawa representative about occurrence status (operating procedure).
		1001	The check item number of SV parameter is unmatched.	Software operation error occurred	(1)Turn the power OFF then back ON. (2)If the alarm occurs again, save the CMOS.BIN in maintenance mode, and then contact your Yaskawa representative about occurrence status (operating procedure).
		1002	The check item number of SVM parameter is unmatched.	Software operation error occurred	(1)Turn the power OFF then back ON. (2)If the alarm occurs again, save the CMOS.BIN in maintenance mode, and then contact your Yaskawa representative about occurrence status (operating procedure).
		1003	The check item number of SVP parameter is unmatched.	Software operation error occurred	(1)Turn the power OFF then back ON. (2)If the alarm occurs again, save the CMOS.BIN in maintenance mode, and then contact your Yaskawa representative about occurrence status (operating procedure).
		1004	The check item number of AMC parameter is unmatched.	Software operation error occurred	(1)Turn the power OFF then back ON. (2)If the alarm occurs again, save the CMOS.BIN in maintenance mode, and then contact your Yaskawa representative about occurrence status (operating procedure).

Alarm Number	Alarm Name	Sub Code	Meaning	Cause	Remedy
		1005	The check item number of MFG parameter is unmatched.	Software operation error occurred	(1)Turn the power OFF then back ON. (2)If the alarm occurs again, save the CMOS.BIN in maintenance mode, and then contact your Yaskawa representative about occurrence status (operating procedure).
		1006	The check item number of MFA parameter is unmatched.	Software operation error occurred	(1)Turn the power OFF then back ON. (2)If the alarm occurs again, save the CMOS.BIN in maintenance mode, and then contact your Yaskawa representative about occurrence status (operating procedure).
		1007	The check item number of SVC parameter is unmatched.	Software operation error occurred	(1)Turn the power OFF then back ON. (2)If the alarm occurs again, save the CMOS.BIN in maintenance mode, and then contact your Yaskawa representative about occurrence status (operating procedure).
		4000	Execution of the motion command does not complete within the specified time. (The last three digits expresses the command code.)	Software operation error occurred	(1)Turn the power OFF then back ON. (2)If the alarm occurs again, save the CMOS.BIN in maintenance mode, and then contact your Yaskawa representative about occurrence status (operating procedure).
		7200	Interpolation cycle is shorter than the set value. (The last digit expresses the physical axis of the alarm occurrence.)	Software operation error occurred	(1)Turn the power OFF then back ON. (2)If the alarm occurs again, save the CMOS.BIN in maintenance mode, and then contact your Yaskawa representative about occurrence status (operating procedure).
		7500	Setting error of the NSRCH instruction direct-in number.	Setting error	More than 4 direct in numbers are specified at time under the NSRCH instruction. Confirm its direct-in setting value.
1200	HIGH TEMPERATURE (IN CNTL BOX)			The temperature rises in the controller	Turn the power OFF then back ON after cooling down inside of the controller.
				Connection failure	(1)Turn the power OFF then back ON. (2)If the alarm occurs again, check the connecting state of the following cables. ·The power cables of the cooling fan inside of the converter unit.
				Module failure (converter)	(1)Turn the power OFF then back ON. (2)If the alarm occurs again, replace controller. Save the CMOS.BIN before replace controller to be safe.
1204	COMMUNICATION ERROR (OPTION MODULE)		The communication error slot (Serial-bus-connected Option module communication station No.) is displayed by the bit. 0: correct / 1: incorrect	Connection failure	Check the connecting or inserting state of the followings. ·Option modules of the corresponding slot. ·Option module cables of the corresponding slot.
				IO module failure	Replace the I/O module of the corresponding station number.

Alarm Number	Alarm Name	Sub Code	Meaning	Cause	Remedy
				Power supply broken	Replace the 24V power supply supplied to the I/O module of the corresponding station number.
				Main CPU board broken	Save the CMOS.BIN file. Replace the Main CPU board, and then load the saved CMOS.BIN file.
1220	LAN COMMUNICATION PARAMETER ERROR	1	Incorrect setting of the IP address which is used in the Ethernet function.	Setting error	(1)Check the following settings. ·IP address setting of network in maintenance mode
		2	Incorrect setting of the subnet mask which is used in the Ethernet function.	Setting error	(1)Check the following settings. ·Subnet mask of network in maintenance mode
		3	Incorrect setting of the default gateway which is used in the Ethernet function.	Setting error	(1)Check the following settings. ·Default gateway of network in maintenance mode
		4	Incorrect setting of the host address which is used in the Ethernet function.	Setting error	(1)Check the following settings. ·Server (host) of network in maintenance mode
		70	Incorrect setting of the host name which is used in the Ethernet function.	Setting error	(1)Check the following settings. ·Host name of network in maintenance mode
		75	Incorrect setting of the domain which is used in the Ethernet function.	Setting error	(1)Check the following settings. ·Domain name of network in maintenance mode
1221	ETHERNET INITIAL PROCESS ERROR	1	An error occurred in the device initialization process of the Ethernet function.	Software operation error occurred	(1)Turn the power OFF then back ON. (2)If the alarm occurs again, save the CMOS.BIN in maintenance mode, and then contact your Yaskawa representative about occurrence status (operating procedure).
				Main CPU board failure	(1)Turn the power OFF then back ON. (2)If the alarm occurs again, replace controller.
		2	An error occurred in the IP address setting process of the Ethernet function.	Setting error	(1)Check the following settings. ·IP address setting of network in maintenance mode
				Software operation error occurred	(1)Turn the power OFF then back ON. (2)If the alarm occurs again, save the CMOS.BIN in maintenance mode, and then contact your Yaskawa representative about occurrence status (operating procedure).
				Main CPU board failure	(1)Turn the power OFF then back ON. (2)If the alarm occurs again, replace controller.

Alarm Number	Alarm Name	Sub Code	Meaning	Cause	Remedy
		3	An error occurred in the subnet mask setting process of the Ethernet function.	Setting error	(1)Check the following settings. ·Subnet mask of network in maintenance mode
				Software operation error occurred	(1)Turn the power OFF then back ON. (2)If the alarm occurs again, save the CMOS.BIN in maintenance mode, and then contact your Yaskawa representative about occurrence status (operating procedure).
				Main CPU board failure	(1)Turn the power OFF then back ON. (2)If the alarm occurs again, replace controller.
		4	An error occurred in the default gateway setting process of the Ethernet function.	Setting error	(1)Check the following settings. ·Default gateway of network in maintenance mode
				Software operation error occurred	(1)Turn the power OFF then back ON. (2)If the alarm occurs again, save the CMOS.BIN in maintenance mode, and then contact your Yaskawa representative about occurrence status (operating procedure).
				Main CPU board failure	(1)Turn the power OFF then back ON. (2)If the alarm occurs again, replace controller.
		5	An error occurred in the host name setting process of the Ethernet function.	Setting error	(1)Check the following settings. ·Server (host) of network in maintenance mode
				Software operation error occurred	(1)Turn the power OFF then back ON. (2)If the alarm occurs again, save the CMOS.BIN in maintenance mode, and then contact your Yaskawa representative about occurrence status (operating procedure).
				Main CPU board failure	(1)Turn the power OFF then back ON. (2)If the alarm occurs again, replace controller.
		6	An error occurred in the MAC address getting process of the Ethernet function.	Software operation error occurred	(1)Turn the power OFF then back ON. (2)If the alarm occurs again, save the CMOS.BIN in maintenance mode, and then contact your Yaskawa representative about occurrence status (operating procedure).
				Main CPU board failure	(1)Turn the power OFF then back ON. (2)If the alarm occurs again, replace controller.
		20	An error occurred in the Web server task creating process of the Ethernet function.	Software operation error occurred	(1)Turn the power OFF then back ON. (2)If the alarm occurs again, save the CMOS.BIN in maintenance mode, and then contact your Yaskawa representative about occurrence status (operating procedure).

Alarm Number	Alarm Name	Sub Code	Meaning	Cause	Remedy
				Main CPU board failure	(1)Turn the power OFF then back ON. (2)If the alarm occurs again, replace controller.
		21	An error occurred in the FTP server task creating process of the Ethernet function.	Software operation error occurred	(1)Turn the power OFF then back ON. (2)If the alarm occurs again, save the CMOS.BIN in maintenance mode, and then contact your Yaskawa representative about occurrence status (operating procedure).
				Main CPU board failure	(1)Turn the power OFF then back ON. (2)If the alarm occurs again, replace controller.
		22	An error occurred in the FTP client task creating process of the Ethernet function.	Software operation error occurred	(1)Turn the power OFF then back ON. (2)If the alarm occurs again, save the CMOS.BIN in maintenance mode, and then contact your Yaskawa representative about occurrence status (operating procedure).
				Main CPU board failure	(1)Turn the power OFF then back ON. (2)If the alarm occurs again, replace controller.
		30	An error occurred in the semaphore generation process for access exclusion of the Ethernet function.	Software operation error occurred	(1)Turn the power OFF then back ON. (2)If the alarm occurs again, save the CMOS.BIN in maintenance mode, and then contact your Yaskawa representative about occurrence status (operating procedure).
				Main CPU board failure	(1)Turn the power OFF then back ON. (2)If the alarm occurs again, replace controller.
		50	An error occurred in the Web server task management ID getting process of the Ethernet function.	Software operation error occurred	(1)Turn the power OFF then back ON. (2)If the alarm occurs again, save the CMOS.BIN in maintenance mode, and then contact your Yaskawa representative about occurrence status (operating procedure).
				Main CPU board failure	(1)Turn the power OFF then back ON. (2)If the alarm occurs again, replace controller.
		51	An error occurred in the FTP server task management ID getting process of the Ethernet function.	Software operation error occurred	(1)Turn the power OFF then back ON. (2)If the alarm occurs again, save the CMOS.BIN in maintenance mode, and then contact your Yaskawa representative about occurrence status (operating procedure).
				Main CPU board failure	(1)Turn the power OFF then back ON. (2)If the alarm occurs again, replace controller.
1301	COMMUNICATION ERROR (SERVO)	0	Communication status error	Connection failure	(1)Turn the power OFF then back ON. (2)If the alarm occurs again, replace controller. Save the CMOS.BIN before replace controller to be safe.

Alarm Number	Alarm Name	Sub Code	Meaning	Cause	Remedy
				Module failure (converter)	(1)Turn the power OFF then back ON. (2)If the alarm occurs again, replace controller. Save the CMOS.BIN before replace controller to be safe.
				Servo control board failure	(1)Turn the power OFF then back ON. (2)If the alarm occurs again, replace controller. Save the CMOS.BIN before replace controller to be safe.
				Main CPU board failure	(1)Turn the power OFF then back ON. (2)If the alarm occurs again, replace controller. Save the CMOS.BIN before replace controller to be safe.
		1	Watchdog timer error	Connection failure	(1)Turn the power OFF then back ON. (2)If the alarm occurs again, replace controller. Save the CMOS.BIN before replace controller to be safe.
				Module failure (converter)	(1)Turn the power OFF then back ON. (2)If the alarm occurs again, replace controller. Save the CMOS.BIN before replace controller to be safe.
				Servo control board failure	(1)Turn the power OFF then back ON. (2)If the alarm occurs again, replace controller. Save the CMOS.BIN before replace controller to be safe.
				Main CPU board failure	(1)Turn the power OFF then back ON. (2)If the alarm occurs again, replace controller. Save the CMOS.BIN before replace controller to be safe.
		2	JL0101 alarm	Connection failure	(1)Turn the power OFF then back ON. (2)If the alarm occurs again, replace controller. Save the CMOS.BIN before replace controller to be safe.
				Module failure (converter)	(1)Turn the power OFF then back ON. (2)If the alarm occurs again, replace controller. Save the CMOS.BIN before replace controller to be safe.
				Servo control board failure	(1)Turn the power OFF then back ON. (2)If the alarm occurs again, replace controller. Save the CMOS.BIN before replace controller to be safe.
				Main CPU board failure	(1)Turn the power OFF then back ON. (2)If the alarm occurs again, replace controller. Save the CMOS.BIN before replace controller to be safe.
		3	Communication status error	Connection failure	(1)Turn the power OFF then back ON. (2)If the alarm occurs again, replace controller. Save the CMOS.BIN before replace controller to be safe.

Alarm Number	Alarm Name	Sub Code	Meaning	Cause	Remedy
				Module failure (converter)	(1)Turn the power OFF then back ON. (2)If the alarm occurs again, replace controller. Save the CMOS.BIN before replace controller to be safe.
				Servo control board failure	(1)Turn the power OFF then back ON. (2)If the alarm occurs again, replace controller. Save the CMOS.BIN before replace controller to be safe.
				Main CPU board failure	(1)Turn the power OFF then back ON. (2)If the alarm occurs again, replace controller. Save the CMOS.BIN before replace controller to be safe.
		4	Data consistency error	Connection failure	(1)Turn the power OFF then back ON. (2)If the alarm occurs again, replace controller. Save the CMOS.BIN before replace controller to be safe.
				Module failure (converter)	(1)Turn the power OFF then back ON. (2)If the alarm occurs again, replace controller. Save the CMOS.BIN before replace controller to be safe.
				Servo control board failure	(1)Turn the power OFF then back ON. (2)If the alarm occurs again, replace controller. Save the CMOS.BIN before replace controller to be safe.
				Main CPU board failure	(1)Turn the power OFF then back ON. (2)If the alarm occurs again, replace controller. Save the CMOS.BIN before replace controller to be safe.
				Software operation error occurred	(1)Turn the power OFF then back ON. (2)If the alarm occurs again, save the CMOS.BIN in maintenance mode, and then contact your Yaskawa representative about occurrence status (operating procedure).
1303	ARITHMETIC ERROR (SERVO)		The data [X____] indicates the generation process. 10000: Observer control 20000: High-precision path control 30000: Dynamics 40000: Disturbance observer control 50000: Dislocation detect The data [_YYY_] indicates the alarm contents. The data [____Z] indicates the physical axis number.	Tool file setting error	(1)Check the following settings. Reexamine the tool file setting. (Check the units of mass and center of gravity, positive/negative signs.)

Alarm Number	Alarm Name	Sub Code	Meaning	Cause	Remedy
				Software operation error occurred	(1)Turn the power OFF then back ON. (2)If the alarm occurs again, save the CMOS.BIN in maintenance mode, and then contact your Yaskawa representative about occurrence status (operating procedure).
				Motor load error	(1)Check the followings. Overload is applied to the manipulator. Correct the tools, the work pieces, and the drive condition.
1306	AMPLIFIER TYPE MISMATCH		Sub Code: Signifies the axis in which the alarm occurred	Setting error	(1)Check the following settings. ·Check the current capacity of the amplifier before/after replacement by the model described in board. ·When the external axis is mounted, check if there is no difference between the amplifier selected at configuration and practically mounted one. Reference parameter: from SVPxG232
				Connection failure	(1)Turn the power OFF then back ON. (2)If the alarm occurs again, replace controller. Save the CMOS.BIN before replace controller to be safe.
				Module failure (amplifier)	(1)Turn the power OFF then back ON. (2)If the alarm occurs again, replace controller. Save the CMOS.BIN before replace controller to be safe.
				Servo control board failure	(1)Turn the power OFF then back ON. (2)If the alarm occurs again, replace controller. Save the CMOS.BIN before replace controller to be safe.
1307	ENCODER TYPE MISMATCH		Sub Code: Signifies the axis in which the alarm occurred	Setting error	(1)Check the following settings. ·Check the motor type before and after the replacement. ·When the external axis is mounted, check if there is no difference between the motor selected at configuration and the motor that is actually mounted.
				Connection failure	(1)Turn the power OFF then back ON. (2)If the alarm occurs again, replace controller. Save the CMOS.BIN before replace controller to be safe.
				Module failure (encoder)	(1)Turn the power OFF then back ON. (2)If the alarm occurs again, replace the encoder.
				Servo control board failure	(1)Turn the power OFF then back ON. (2)If the alarm occurs again, replace controller. Save the CMOS.BIN before replace controller to be safe.
				Software operation error occurred	(1)Turn the power OFF then back ON. (2)If the alarm occurs again, save the CMOS.BIN in maintenance mode, and then contact your Yaskawa representative about occurrence status (operating procedure).

Alarm Number	Alarm Name	Sub Code	Meaning	Cause	Remedy
1308	CONVERTER TYPE MISMATCH		Sub Code: Signifies the converter in which the alarm occurred	Setting error	(1)Check the following settings. ·Check the current capacity of the amplifier before/after replacement by the model described in board. ·When the external axis is mounted, check if there is no difference between the amplifier selected at configuration and practically mounted one. Reference parameter: from SVCxB025
				Connection failure	(1)Turn the power OFF then back ON. (2)If the alarm occurs again, replace controller. Save the CMOS.BIN before replace controller to be safe.
				Module failure (converter)	(1)Turn the power OFF then back ON. (2)If the alarm occurs again, replace controller. Save the CMOS.BIN before replace controller to be safe.
				Servo control board failure	(1)Turn the power OFF then back ON. (2)If the alarm occurs again, replace controller. Save the CMOS.BIN before replace controller to be safe.
				Software operation error occurred	(1)Turn the power OFF then back ON. (2)If the alarm occurs again, save the CMOS.BIN in maintenance mode, and then contact your Yaskawa representative about occurrence status (operating procedure).
1311	A/D DETECTION ERROR (CONVERTER)		Sub Code: Signifies the converter physical number in which the alarm occurred	Module failure (converter)	(1)Turn the power OFF then back ON. (2)If the alarm occurs again, replace controller. Save the CMOS.BIN before replace controller to be safe.
1325	COMMUNICATION ERROR (ENCODER)		Sub Code: Signifies the axis in which the alarm occurred	Connection failure	(1)Turn the power OFF then back ON. (2)If the alarm occurs again, check the connecting or inserting state of the following cables. {Robot axis} ·Cables between the controller and the encoder. {External axis} ·Cables between the controller and the encoder.
				Module failure (encoder)	(1)Turn the power OFF then back ON. (2)If the alarm occurs again, replace the encoder.
				Servo control board failure	(1)Turn the power OFF then back ON. (2)If the alarm occurs again, replace controller. Save the CMOS.BIN before replace controller to be safe.

Alarm Number	Alarm Name	Sub Code	Meaning	Cause	Remedy
1326	DEFECTIVE ENCODER ABSOLUTE DATA		Sub Code: Signifies the axis in which the alarm occurred	Connection failure	(1)Turn the power OFF then back ON. (2)If the alarm occurs again, check the connecting or inserting state of the following cables. {Robot axis} ·Cables between the controller and the encoder. {External axis} ·Cables between the controller and the encoder.
				Module failure (encoder)	(1)Check the following settings. Replace the defective motor (encoder). ·Check the position after the alarm.
				Servo control board failure	(1)Turn the power OFF then back ON. (2)If the alarm occurs again, replace controller. Save the CMOS.BIN before replace controller to be safe.
				External environment	(1)Check the following settings. ·Check the grounding condition of Manipulator. ·Check whether it is installed into the strong magnetic field. ·Check the position after the alarm.
1327	ENCODER OVER SPEED		Sub Code: Signifies the axis in which the alarm occurred	Connection failure	(1)Turn the power OFF then back ON. (2)Turn the servo OFF where the axis does not fall off while turning ON the servo. (3)Replace the battery of the alarm occurring axis if the alarm and encoder back-up error occur again. (4)If the alarm occurs again, check the connecting or inserting state of the following cables. {Robot axis} ·Cables between the controller and the encoder. {External axis} ·Cables between the controller and the encoder
				Encoder failure	Replace the defective motor (encoder).
				Servo control board failure	(1)Turn the power OFF then back ON. (2)If the alarm occurs again, replace controller. Save the CMOS.BIN before replace controller to be safe.

Alarm Number	Alarm Name	Sub Code	Meaning	Cause	Remedy
1328	DEFECTIVE ENCODER		Sub Code: Signifies the axis in which the alarm occurred	Connection failure	(1)Turn the power OFF then back ON. (2)If the alarm occurs again, check the connecting or inserting state of the following cables. {Robot axis} ·Cables between the controller and the encoder. {External axis} ·Cables between the controller and the encoder
				Module failure (encoder)	(1)Turn the power OFF then back ON. (2)If the alarm occurs again, replace the encoder.
				Servo control board failure	(1)Turn the power OFF then back ON. (2)If the alarm occurs again, replace controller. Save the CMOS.BIN before replace controller to be safe.
1329	DEFECTIVE SERIAL ENCODER COMMAND		Sub Code: Signifies the axis in which the alarm occurred	Connection failure	(1)Turn the power OFF then back ON. (2)If the alarm occurs again, check the connecting or inserting state of the following cables. {Robot axis} ·Cables between the controller and the encoder. {External axis} ·Cables between the controller and the encoder.
				Module failure (encoder)	(1)Turn the power OFF then back ON. (2)If the alarm occurs again, replace the encoder.
				Servo control board failure	(1)Turn the power OFF then back ON. (2)If the alarm occurs again, replace controller. Save the CMOS.BIN before replace controller to be safe.
1330	MICRO PROGRAM TRANSMIT ERROR		Sub Code: Signifies the axis in which the alarm occurred	Servo control board failure	(1)Turn the power OFF then back ON. (2)If the alarm occurs again, replace controller. Save the CMOS.BIN before replace controller to be safe.
1349	POWER LOST DETECTION (SERVO)			Instant power failure	Check if the primary power supply voltage is dropping.
1352	SERIAL ENCODER CORRECTION ERROR		Sub Code: Signifies the axis in which the alarm occurred	Connection failure	(1)Turn the power OFF then back ON. (2)If the alarm occurs again, check the connecting or inserting state of the following cables. {Robot axis} ·Cables between the controller and the encoder. {External axis} ·Cables between the controller and the encoder.

Alarm Number	Alarm Name	Sub Code	Meaning	Cause	Remedy
				Connection failure	(1)Turn the power OFF then back ON. (2)If the alarm occurs again, check the connection and insertion of the following cables and connectors. {Robot axis} ·Cable between encoders ·EAXA-CN508 {External axis} ·Cable between encoders ·EAXB-CN0534,535,536
				Module failure (encoder)	(1)Turn the power OFF then back ON. (2)If the alarm occurs again, replace the encoder.
				Servo control board failure	(1)Turn the power OFF then back ON. (2)If the alarm occurs again, replace controller. Save the CMOS.BIN before replace controller to be safe.
1355	SERIAL ENC MULTITURN LIMIT ERROR		Sub Code: Signifies the axis in which the alarm occurred	Connection failure	(1)Turn the power OFF then back ON. (2)If the alarm occurs again, check the connecting or inserting state of the following cables. {Robot axis} ·Cables between the controller and the encoder. {External axis} ·Cables between the controller and the encoder.
				Connection failure	(1)Turn the power OFF then back ON. (2)If the alarm occurs again, check the connection and insertion of the following cables and connectors. {Robot axis} ·Cable between encoders ·EAXA-CN508 {External axis} ·Cable between encoders ·EAXB-CN0534,535,536
				Module failure (encoder)	(1)Turn the power OFF then back ON. (2)If the alarm occurs again, replace the encoder.
				Servo control board failure	(1)Turn the power OFF then back ON. (2)If the alarm occurs again, replace controller. Save the CMOS.BIN before replace controller to be safe.
1400	ENCODER ERROR (CONVEYOR)	1	An error occurred at conveyor encoder 1.	Cable (defect), Module failure (encoder)	Replace the encoder cable or encoder of the conveyor encoder 1.

Alarm Number	Alarm Name	Sub Code	Meaning	Cause	Remedy
		2	An error occurred at conveyor encoder 2.	Cable (defect), Module failure (encoder)	Replace the encoder cable or encoder of the conveyor encoder 2.
		3	An error occurred at conveyor encoder 3.	Cable (defect), Module failure (encoder)	Replace the encoder cable or encoder of the conveyor encoder 3.
1401	CANNOT CHANGE CONVEYOR MODE			Input error	Do not switch "Encoder / Virtual encoder" with the general signal while performing the conveyor synchronized function.
1402	WORK IN/NOT DATA CNT. LMT. OVER			Work status error	Check the work in/not shift data and actual the work status within the shift area.
1403	WORK IN/NOT SHIFT DATA POS LMT.			Work status error	Check the work in/not shift data and actual the work status within the shift area.
1404	WORK ID. DATA CNT. LMT. OVER			Work status error	Check the work in/not shift data and actual the work status within the shift area.
1405	WORK ID. SHIFT DATA POS LMT.			Work status error	Check the work in/not shift data and actual the work status within the shift area.
1406	START SHIFT DATA CNT. LMT. OVER			Work status error	Check the work in/not shift data and actual the work status within the shift area.
1407	START SHIFT DATA POS LMT.			Work status error	Check the work in/not shift data and actual the work status within the shift area.
1512	POWER SUPPLY FAN ERROR (SERVO)			Connection failure	(1)Turn the power OFF then back ON. (2)If the alarm occurs again, replace controller. Save the CMOS.BIN before replace controller to be safe.
				Module failure (converter)	(1)Turn the power OFF then back ON. (2)If the alarm occurs again, replace controller. Save the CMOS.BIN before replace controller to be safe.
				Air inlet and exhaust	Check that the air inlet or outlet is not blocked.
1513	POWER SUPPLY OVERHEAT (SERVO)			The temperature rises in the controller	Turn the power OFF then back ON after cooling the controller.
				Connection failure	(1)Turn the power OFF then back ON. (2)If the alarm occurs again, replace controller. Save the CMOS.BIN before replace controller to be safe.
				Module failure (converter)	(1)Turn the power OFF then back ON. (2)If the alarm occurs again, replace controller. Save the CMOS.BIN before replace controller to be safe.

Alarm Number	Alarm Name	Sub Code	Meaning	Cause	Remedy
1514	OVERHEAT (AMPLIFIER)			The temperature of amplifier rose.	Turn the power OFF then back ON after cooling the amplifier.
				Connection failure	(1)Turn the power OFF then back ON. (2)If the alarm occurs again, replace controller. Save the CMOS.BIN before replace controller to be safe.
				Servo control board failure	(1)Turn the power OFF then back ON. (2)If the alarm occurs again, replace controller. Save the CMOS.BIN before replace controller to be safe.
1547	CURRENT FEEDBACK ERROR		<ul style="list-style-type: none"> •The data [XXX_] indicates the alarm contents. •2000:Error in current detection value •The data [__Y] indicates the physical axis number. 	Connection failure	Check if a ground fault has not occurred in the U-, V-, and W-phase of motor power line, or short circuit has not occurred between these phases.
				Connection failure	(1)Turn the power OFF then back ON. (2)If the alarm occurs again, replace controller. Save the CMOS.BIN before replace controller to be safe.
				Module failure (amplifier)	(1)Turn the power OFF then back ON. (2)If the alarm occurs again, replace controller. Save the CMOS.BIN before replace controller to be safe.
				Module failure (motor)	(1)Turn the power OFF then back ON. (2)If the alarm occurs again, replace the motor.
				Servo control board failure	(1)Turn the power OFF then back ON. (2)If the alarm occurs again, replace controller. Save the CMOS.BIN before replace controller to be safe.
1650	FILE TRANSFER DATA ERROR (SV)	1	An error occurred when the last data was not received during the first data communication at execution of motion command.	Software operation error occurred	(1)Turn the power OFF then back ON. (2)If the alarm occurs again, save the CMOS.BIN in maintenance mode, and then contact your Yaskawa representative about occurrence status (operating procedure).
				Servo control board failure	(1)Turn the power OFF then back ON. (2)If the alarm occurs again, replace controller. Save the CMOS.BIN before replace controller to be safe.
				Main CPU board failure	(1)Turn the power OFF then back ON. (2)If the alarm occurs again, replace controller. Save the CMOS.BIN before replace controller to be safe.

Alarm Number	Alarm Name	Sub Code	Meaning	Cause	Remedy
				Main CPU board failure	(1)Turn the power OFF then back ON. (2)If the alarm occurs again, replace controller. Save the CMOS.BIN before replace controller to be safe.
		2	An error occurred when the first data was not received during on the way data communication at execution of motion command.	Servo control board failure	(1)Turn the power OFF then back ON. (2)If the alarm occurs again, replace controller. Save the CMOS.BIN before replace controller to be safe.
		3	An error occurred when the first data was not received during the last data communication at execution of motion command.	Servo control board failure	(1)Turn the power OFF then back ON. (2)If the alarm occurs again, replace controller. Save the CMOS.BIN before replace controller to be safe.
1651	FILE TRANSFER DATA SIZE ERRORERROR (SV)	1	The data size for the file transfer does not agree with the received buffer size.	Servo control board failure	(1)Turn the power OFF then back ON. (2)If the alarm occurs again, replace controller. Save the CMOS.BIN before replace controller to be safe.
		2	Buffer size over	Servo control board failure	(1)Turn the power OFF then back ON. (2)If the alarm occurs again, replace controller. Save the CMOS.BIN before replace controller to be safe.
1652	DB ON ERROR (SERVO)			Servo control board failure	(1)Turn the power OFF then back ON. (2)If the alarm occurs again, replace controller. Save the CMOS.BIN before replace controller to be safe.
				Software operation error occurred	(1)Turn the power OFF then back ON. (2)If the alarm occurs again, save the CMOS.BIN in maintenance mode, and then contact your Yaskawa representative about occurrence status (operating procedure).
1653	BASE BLOCK SIGNAL ERROR (SERVO)			Servo control board failure	(1)Turn the power OFF then back ON. (2)If the alarm occurs again, replace controller. Save the CMOS.BIN before replace controller to be safe.
				Software operation error occurred	(1)Turn the power OFF then back ON. (2)If the alarm occurs again, save the CMOS.BIN in maintenance mode, and then contact your Yaskawa representative about occurrence status (operating procedure).
				Module failure (amplifier)	(1)Turn the power OFF then back ON. (2)If the alarm occurs again, replace controller. Save the CMOS.BIN before replace controller to be safe.

Alarm Number	Alarm Name	Sub Code	Meaning	Cause	Remedy
1654	PG POWER ON MULTIPLE REQ (SV)			Setting error	(1)Turn the power OFF then back ON. (2)If the alarm occurs again, save the CMOS.BIN in maintenance mode, and then contact your Yaskawa representative about occurrence status (operating procedure).
1655	CONVERTER COMMAND ERROR (SV)			Software operation error occurred	(1)Turn the power OFF then back ON. (2)If the alarm occurs again, save the CMOS.BIN in maintenance mode, and then contact your Yaskawa representative about occurrence status (operating procedure).
1656	AXIS ENDLESS INFO NOT GENERATED(SV)			Setting error	Check the JOB. (1)Turn the power OFF then back ON. (2)If the alarm occurs again, replace controller. Save the CMOS.BIN before replace controller to be safe.
1657	AXIS ENDLESS SPECIFIC. ERROR (SV)	1	The home position detecting function was used for the axis for which the axis endless function was enabled. The home position detecting function cannot be used for the axis which the axis endless function was enabled.	Setting error	Disable either the axis endless function or the home position detection function of corresponding axis.
		2	The servo float function was used for the axis for which the axis endless function was enabled. The servo float function cannot be used for the axis which the axis endless function was enabled.	Setting error	Disable either the axis endless function or the servo float function of corresponding axis.
		3	The encoders manufactured by Tamagawa Seiki Co., Ltd. was used for the axis for which the axis endless function was enabled. The encoders manufactured by Tamagawa Seiki Co., Ltd. cannot be used for the axis which the axis endless function was enabled.	Setting error	Disable the corresponding axis endless function.

Alarm Number	Alarm Name	Sub Code	Meaning	Cause	Remedy
		4	The general servo function was used for the axis for which the axis endless function was enabled. The general servo function cannot be used for the axis which the axis endless function was enabled.	Setting error	Disable the corresponding axis endless function.
1658	REDUCTION STOP SPECIFIC. ERROR (SV)	1	The servo float function was used for the axis for which the deceleration stop function was enabled. The servo float function cannot be used for the axis which the deceleration stop function was enabled.	Setting error	Check the JOB.
		2	The specified axis speed control function was executed for the axis which the deceleration stop function was enabled. Specified axis speed control function cannot be used for the axis which the deceleration stop function was enabled.	Setting error	Check the JOB.
1664	MICRO PRG EXECUTE TIME OVER(SV)		Sub code: specifies the axis that alarm occurred.	Servo control board failure	(1)Turn the power OFF then back ON. (2)If the alarm occurs again, replace controller. Save the CMOS.BIN before replace controller to be safe.
1665	MICRO PROGRAM SYNC. ERROR (SV)		Sub code: specifies the axis that alarm occurred.	Servo control board failure	(1)Turn the power OFF then back ON. (2)If the alarm occurs again, replace controller. Save the CMOS.BIN before replace controller to be safe.
1666	FILE RECEIVE INCOMPLETE (SERVO)		Sub code: specifies the axis that alarm occurred.	Servo control board failure	(1)Turn the power OFF then back ON. (2)If the alarm occurs again, replace controller. Save the CMOS.BIN before replace controller to be safe.
1667	RESOLUTION CONVERSE CONST ERROR (SV)			Servo control board failure	(1)Turn the power OFF then back ON. (2)If the alarm occurs again, replace controller. Save the CMOS.BIN before replace controller to be safe.

Alarm Number	Alarm Name	Sub Code	Meaning	Cause	Remedy
1674	CTRL LAW SWITCHING ORDER ERROR (SV)		Sub code: specifies the axis that alarm occurred.	Servo control board failure	(1)Turn the power OFF then back ON. (2)If the alarm occurs again, replace controller. Save the CMOS.BIN before replace controller to be safe.
1684	INSTANT POWER FAILURE (TRQ)(SV)		The instant power failure occurred and then the torque was saturated.	Voltage failure	Check if the primary power supply voltage is dropping.
				Power failure	Check if the instant power failure has occurred.
1685	INSTANT POWER FAILURE (TIME)(SV)		The instant power failure occurred for longer than the certain time period.	Voltage failure	Check if the primary power supply voltage is dropping.
				Power failure	Check if the instant power failure has occurred.
1686	POS.DEVITATION SATURATING ERROR (SV)			Setting error	Check the settings for manipulator motion condition (influence by external force, load condition).
				Connection failure	Check if a ground fault has not occurred in the U-, V-, and W-phase of motor power line, or short circuit has not occurred between these phases.
				Connection failure	Check the connection of motor power line.
				Module failure (motor)	(1)Turn the power OFF then back ON. (2)If the alarm occurs again, replace the motor.
				Servo control board failure	(1)Turn the power OFF then back ON. (2)If the alarm occurs again, replace controller. Save the CMOS.BIN before replace controller to be safe.
				Module failure (amplifier)	(1)Turn the power OFF then back ON. (2)If the alarm occurs again, replace controller. Save the CMOS.BIN before replace controller to be safe.
1831	HWBB FB ERROR (PLD2)			Machine safety board failure	(1)Turn the power OFF then back ON. (2)If the alarm occurs again, replace controller. Save the CMOS.BIN before replace controller to be safe.
				Servo control board failure	(1)Turn the power OFF then back ON. (2)If the alarm occurs again, replace controller. Save the CMOS.BIN before replace controller to be safe.
1832	ESP_OUT FB ERROR (PLD1)			Machine safety board failure	(1)Turn the power OFF then back ON. (2)If the alarm occurs again, replace controller. Save the CMOS.BIN before replace controller to be safe.

Alarm Number	Alarm Name	Sub Code	Meaning	Cause	Remedy
1833	ESP_OUT FB ERROR (PLD2)			Machine safety board failure	(1)Turn the power OFF then back ON. (2)If the alarm occurs again, replace controller. Save the CMOS.BIN before replace controller to be safe.
1834	M-SAFETY WATCHDOG ERROR (PLD1)			Machine safety board failure	(1)Turn the power OFF then back ON. (2)If the alarm occurs again, replace controller. Save the CMOS.BIN before replace controller to be safe.
1835	M-SAFETY WATCHDOG ERROR (PLD2)			Machine safety board failure	(1)Turn the power OFF then back ON. (2)If the alarm occurs again, replace controller. Save the CMOS.BIN before replace controller to be safe.
1836	M-SAFETY WATCHDOG ERROR (PLD3)			Machine safety board failure	(1)Turn the power OFF then back ON. (2)If the alarm occurs again, replace controller. Save the CMOS.BIN before replace controller to be safe.
				Main CPU board failure	(1)Turn the power OFF then back ON. (2)If the alarm occurs again, replace controller. Save the CMOS.BIN before replace controller to be safe.
				Software operation error occurred	(1)Turn the power OFF then back ON. (2)If the alarm occurs again, save the CMOS.BIN in maintenance mode, and then contact your Yaskawa representative about occurrence status (operating procedure).
1837	M-SAFETY 24V POWER SUPPLY ERROR			Connection failure	(1)Turn the power OFF then back ON. (2)If the alarm occurs again, save the CMOS.BIN in maintenance mode, and then contact your Yaskawa representative about occurrence status (operating procedure).
				Machine safety board failure	(1)Turn the power OFF then back ON. (2)If the alarm occurs again, replace controller. Save the CMOS.BIN before replace controller to be safe.
				Ground fault or a short circuit	(1)Turn the power OFF then back ON. (2)If the alarm occurs again, replace controller. Save the CMOS.BIN before replace controller to be safe.
1838	M-SAFETY DC 24V FUSE BROKEN			Blown fuse	(1)Turn the power OFF then back ON. (2)If the alarm occurs again, replace controller. Save the CMOS.BIN before replace controller to be safe.
				Ground fault or a short circuit	(1)Turn the power OFF then back ON. (2)If the alarm occurs again, replace controller. Save the CMOS.BIN before replace controller to be safe.

Alarm Number	Alarm Name	Sub Code	Meaning	Cause	Remedy
				Machine safety board failure	(1)Turn the power OFF then back ON. (2)If the alarm occurs again, replace controller. Save the CMOS.BIN before replace controller to be safe.
1839	M-SAFETY 5V POWER SUPPLY ERROR			Blown fuse	(1)Turn the power OFF then back ON. (2)If the alarm occurs again, replace controller. Save the CMOS.BIN before replace controller to be safe.
				Machine safety board failure	(1)Turn the power OFF then back ON. (2)If the alarm occurs again, replace controller. Save the CMOS.BIN before replace controller to be safe.
1840	M-SAFETY 3.3V LOW VOLTAGE			Machine safety board failure	(1)Turn the power OFF then back ON. (2)If the alarm occurs again, replace controller. Save the CMOS.BIN before replace controller to be safe.
1841	COMMUNICATION ERROR (LOOP BACK)			Connection failure	(1)Turn the power OFF then back ON. (2)If the alarm occurs again, save the CMOS.BIN in maintenance mode, and then contact your Yaskawa representative about occurrence status (operating procedure).
				Servo control board failure	(1)Turn the power OFF then back ON. (2)If the alarm occurs again, replace controller. Save the CMOS.BIN before replace controller to be safe.
				Servo control board failure	(1)Turn the power OFF then back ON. (2)If the alarm occurs again, replace controller. Save the CMOS.BIN before replace controller to be safe.
4000	MEMORY ERROR (TOOL FILE)		Sub Code: Tool number	Data error	(1)Reset the alarm. (2)If the alarm occurs again, initialize the tool file in maintenance mode, and then load the tool file saved in the external memory device.
				Main CPU board failure	(1)Reset the alarm. (2)If the alarm occurs again, replace controller. Save the CMOS.BIN before replace controller to be safe.
4001	MEMORY ERROR (USER COORD FILE)		Sub Code: User coordinate number	Data error	(1)Reset the alarm. (2)If the alarm occurs again, initialize the user coordinates file in maintenance mode, and then load the user coordinates file saved in the external memory device.
				Main CPU board failure	(1)Reset the alarm. (2)If the alarm occurs again, replace controller. Save the CMOS.BIN before replace controller to be safe.

Alarm Number	Alarm Name	Sub Code	Meaning	Cause	Remedy
4002	MEMORY ERROR (SV MON SIGNAL FILE)			Data error	(1)Reset the alarm. (2)If the alarm occurs again, initialize the servo monitor signal file in maintenance mode, and then load the servo monitor signal file saved in the external memory device.
				Main CPU board failure	(1)Reset the alarm. (2)If the alarm occurs again, replace controller. Save the CMOS.BIN before replace controller to be safe.
4004	MEMORY ERROR (HOME POS FILE)			Data error	(1)Reset the alarm. (2)If the alarm occurs again, initialize the home positioning file in maintenance mode, and then load the home positioning file saved in the external memory device.
				Main CPU board failure	(1)Reset the alarm. (2)If the alarm occurs again, replace controller. Save the CMOS.BIN before replace controller to be safe.
4005	MEMORY ERROR (SECOND HOME POS)			Data error	(1)Reset the alarm. (2)If the alarm occurs again, initialize the second home positioning file in maintenance mode, and then load the second home positioning file saved in the external memory device.
				Main CPU board failure	(1)Reset the alarm. (2)If the alarm occurs again, replace controller. Save the CMOS.BIN before replace controller to be safe.
4012	MEMORY ERROR (LINK SERVOFLOAT)		Sub Code: Condition file number	Data error	(1)Reset the alarm. (2)If the alarm occurs again, initialize the link servo float condition file in maintenance mode, and then load the link servo float condition file saved in the external memory device.
				Main CPU board failure	(1)Reset the alarm. (2)If the alarm occurs again, replace controller. Save the CMOS.BIN before replace controller to be safe.
4013	MEMORY ERROR (LINEAR SERVOFLOAT)		Sub Code: Condition file number	Data error	(1)Reset the alarm. (2)If the alarm occurs again, initialize the linear servo float condition file in maintenance mode, and then load the linear servo float condition file saved in the external memory device.
				Main CPU board failure	(1)Reset the alarm. (2)If the alarm occurs again, replace controller. Save the CMOS.BIN before replace controller to be safe.

Alarm Number	Alarm Name	Sub Code	Meaning	Cause	Remedy
4014	MEMORY ERROR (ROBOT CALIB FILE)		Sub Code: Page number	Data error	(1)Reset the alarm. (2)If the alarm occurs again, initialize the file for calibration between manipulators in maintenance mode, and then load the file for calibration between manipulators saved in the external memory device.
				Main CPU board failure	(1)Reset the alarm. (2)If the alarm occurs again, replace controller. Save the CMOS.BIN before replace controller to be safe.
4018	MEMORY ERROR (LADDER PRG FILE)			Data error	(1)Reset the alarm. (2)If the alarm occurs again, initialize the ladder program file in maintenance mode, and then load the ladder program file saved in the external memory device.
				Main CPU board failure	(1)Reset the alarm. (2)If the alarm occurs again, replace controller. Save the CMOS.BIN before replace controller to be safe.
4020	MEMORY ERROR (OPERATION ORIGIN)			Data error	(1)Reset the alarm. (2)If the alarm occurs again, initialize the work home position file in maintenance mode, and then load the work home position file saved in the external memory device.
				Main CPU board failure	(1)Reset the alarm. (2)If the alarm occurs again, replace controller. Save the CMOS.BIN before replace controller to be safe.
4021	MEMORY ERROR (CONVEYOR COND FILE)			Data error	(1)Reset the alarm. (2)If the alarm occurs again, initialize the conveyor condition file in maintenance mode, and then load the conveyor condition file saved in the external memory device.
				Main CPU board failure	(1)Reset the alarm. (2)If the alarm occurs again, replace controller. Save the CMOS.BIN before replace controller to be safe.
4022	MEMORY ERROR (PAINT SPECIAL FILE)		Sub Code: Page number	Data error	(1)Reset the alarm. (2)If the alarm occurs again, initialize the paint special file in maintenance mode, and then load the paint special file saved in the external memory device.
				Main CPU board failure	(1)Reset the alarm. (2)If the alarm occurs again, replace controller. Save the CMOS.BIN before replace controller to be safe.
4023	MEMORY ERROR (PAINT COND FILE)		Sub Code: Page number	Data error	(1)Reset the alarm. (2)If the alarm occurs again, initialize the paint condition file in maintenance mode, and then load the paint condition file saved in the external memory device.

Alarm Number	Alarm Name	Sub Code	Meaning	Cause	Remedy
				Main CPU board failure	(1)Reset the alarm. (2)If the alarm occurs again, replace controller. Save the CMOS.BIN before replace controller to be safe.
4025	MEMORY ERROR (INTERRUPT JOB FILE)			Data error	(1)Reset the alarm. (2)If the alarm occurs again, initialize the interrupt job file in maintenance mode, and then load the interrupt job file saved in the external memory device.
				Main CPU board failure	(1)Reset the alarm. (2)If the alarm occurs again, replace controller. Save the CMOS.BIN before replace controller to be safe.
4028	MEMORY ERROR (SENSOR MON COND FILE)			Data error	(1)Reset the alarm. (2)If the alarm occurs again, initialize the sensor monitoring condition file in maintenance mode, and then load the sensor monitoring condition file saved in the external memory device.
				Main CPU board failure	(1)Reset the alarm. (2)If the alarm occurs again, replace controller. Save the CMOS.BIN before replace controller to be safe.
4034	MEMORY ERROR (ANTICIPATION OT FILE)			Data error	(1)Reset the alarm. (2)If the alarm occurs again, initialize the anticipation output (OT) file in maintenance mode, and then load the anticipation output (OT) file saved in the external memory device.
				Main CPU board failure	(1)Reset the alarm. (2)If the alarm occurs again, replace controller. Save the CMOS.BIN before replace controller to be safe.
4035	MEMORY ERROR (ANTICIPATION OG FILE)			Data error	(1)Reset the alarm. (2)If the alarm occurs again, initialize the anticipation output (OG) file in maintenance mode, and then load the anticipation output (OG) file saved in the external memory device.
				Main CPU board failure	(1)Reset the alarm. (2)If the alarm occurs again, replace controller. Save the CMOS.BIN before replace controller to be safe.
4039	MEMORY ERROR (FORM CUT FILE)		Sub Code: File number	Data error	(1)Reset the alarm. (2)If the alarm occurs again, initialize the form cut file in maintenance mode, and then load the form cut file saved in the external memory device.
				Main CPU board failure	(1)Reset the alarm. (2)If the alarm occurs again, replace controller. Save the CMOS.BIN before replace controller to be safe.

Alarm Number	Alarm Name	Sub Code	Meaning	Cause	Remedy
4040	MEMORY ERROR (SHOCK LEVEL FILE)		Sub Code: File number	Data error	(1)Reset the alarm. (2)If the alarm occurs again, initialize the shock level file in maintenance mode, and then load the shock level file saved in the external memory device.
				Main CPU board failure	(1)Reset the alarm. (2)If the alarm occurs again, replace controller. Save the CMOS.BIN before replace controller to be safe.
4042	MEMORY ERROR (VISION FILE)		Sub Code: Page number	Data error	(1)Reset the alarm. (2)If the alarm occurs again, initialize the vision condition file in maintenance mode, and then load the vision condition file saved in the external memory device.
				Main CPU board failure	(1)Reset the alarm. (2)If the alarm occurs again, replace controller. Save the CMOS.BIN before replace controller to be safe.
4043	MEMORY ERROR (VISION CALIBRATION)		Sub Code: Page number	Data error	(1)Reset the alarm. (2)If the alarm occurs again, initialize the vision calibration file in maintenance mode, and then load the vision calibration file saved in the external memory device.
				Main CPU board failure	(1)Reset the alarm. (2)If the alarm occurs again, replace controller. Save the CMOS.BIN before replace controller to be safe.
4046	MEMORY ERROR (CONVEYOR CALIB FILE)		Sub Code: File number	Data error	(1)Reset the alarm. (2)If the alarm occurs again, initialize the conveyor calibration file in maintenance mode, and then load the conveyor calibration file saved in the external memory device.
				Main CPU board failure	(1)Reset the alarm. (2)If the alarm occurs again, replace controller. Save the CMOS.BIN before replace controller to be safe.
4047	MEMORY ERROR (MACRO DEFINITION FILE)			Data error	(1)Reset the alarm. (2)If the alarm occurs again, initialize the macro definition file in maintenance mode, and then load the macro definition file saved in the external memory device.
				Main CPU board failure	(1)Reset the alarm. (2)If the alarm occurs again, replace controller. Save the CMOS.BIN before replace controller to be safe.
4050	MEMORY ERROR (AXIS I/O ALLOC FILE)			Data error	(1)Reset the alarm. (2)If the alarm occurs again, initialize the axis motion I/O allocation file in maintenance mode, and then load the axis motion I/O allocation file saved in the external memory device.

Alarm Number	Alarm Name	Sub Code	Meaning	Cause	Remedy
				Main CPU board failure	(1)Reset the alarm. (2)If the alarm occurs again, replace controller. Save the CMOS.BIN before replace controller to be safe.
4051	MEMORY ERROR (GUN COND. AUX. FILE)		Sub Code: File number	Data error	(1)Reset the alarm. (2)If the alarm occurs again, initialize the gun characteristics auxiliary file in maintenance mode, and then load the gun characteristics auxiliary file saved in the external memory device.
				Main CPU board failure	(1)Reset the alarm. (2)If the alarm occurs again, replace controller. Save the CMOS.BIN before replace controller to be safe.
4052	MEMORY ERROR (TOOL INTERFERENCE)		Sub Code: File number	Data error	(1)Reset the alarm. (2)If the alarm occurs again, initialize the tool interference file in maintenance mode, and then load the tool interference file saved in the external memory device.
				Main CPU board failure	(1)Reset the alarm. (2)If the alarm occurs again, replace controller. Save the CMOS.BIN before replace controller to be safe.
4063	MEMORY ERROR (CONVEYOR COND SUPP.)		Sub Code: File number	Data error	(1)Reset the alarm. (2)If the alarm occurs again, initialize the conveyor condition auxiliary file in maintenance mode, and then load the conveyor condition auxiliary file saved in the external memory device.
				Main CPU board failure	(1)Reset the alarm. (2)If the alarm occurs again, replace controller. Save the CMOS.BIN before replace controller to be safe.
4065	MEMORY ERROR (I/F PANEL FILE)			Data error	(1)Reset the alarm. (2)If the alarm occurs again, initialize the I/F panel file in maintenance mode, and then load the I/F panel file saved in the external memory device.
				Main CPU board failure	(1)Reset the alarm. (2)If the alarm occurs again, replace controller. Save the CMOS.BIN before replace controller to be safe.
4072	MEMORY ERROR (LASER TRACKING TRACK START FILE)			Data error	(1)Reset the alarm. (2)If the alarm occurs again, initialize the laser tracking track start file in maintenance mode, and then load the laser tracking track start file saved in the external memory device.
				Main CPU board failure	(1)Reset the alarm. (2)If the alarm occurs again, replace controller. Save the CMOS.BIN before replace controller to be safe.

Alarm Number	Alarm Name	Sub Code	Meaning	Cause	Remedy
4074	MEMORY ERROR (LASER TRACKING TRACK SET FILE)			Data error	(1)Reset the alarm. (2)If the alarm occurs again, initialize the laser tracking track set file in maintenance mode, and then load the laser tracking track set file saved in the external memory device.
				Main CPU board failure	(1)Reset the alarm. (2)If the alarm occurs again, replace controller. Save the CMOS.BIN before replace controller to be safe.
4075	MEMORY ERROR (CONDITION FILE OF CORRESPONDING TO LASER TRACKING GAP)			Data error	(1)Reset the alarm. (2)If the alarm occurs again, initialize the condition file of corresponding to laser tracking gap in maintenance mode, and then load the condition file of corresponding to laser tracking gap saved in the external memory device.
				Main CPU board failure	(1)Reset the alarm. (2)If the alarm occurs again, replace controller. Save the CMOS.BIN before replace controller to be safe.
4099	DC 24V POWER SUPPLY FAILURE			Power supply failure	(1)Reset the alarm. (2)If the alarm occurs again, turn the power OFF then back ON. (2)If the alarm occurs again, replace controller. Save the CMOS.BIN before replace controller to be safe.
4103	PARALLEL START INSTRUCTION ERROR	1	Sub task being executed: Although a job is being executed by instructed sub task, an attempt was made to execute another job by the sub task.	Setting error	(1)Check the following settings. ·The subtask is completed by the PWAIT instruction.
		2	Group axis being used: The job operated by another sub task uses the same group axis.	Setting error	(1)Check the following settings. ·The job to be started ·The execution timing for start command
		3	Multiple start of same job: The job that was tried to be started was executed by another sub task.	Setting error	(1)Check the following settings. ·The same job is not used in the another task
		4	Unregistered master job: Although the master job was not registered, an attempt was made to execute PSTART SUB (job name omitted).	Setting error	(1)Check the following settings. ·The master job of the subtask is registered

Alarm Number	Alarm Name	Sub Code	Meaning	Cause	Remedy
		5	Synchronization instruction error: When restarted by PSTART, synchronization instruction status of the sub task under interruption was different from the status to restart.	Setting error	(1)Check the following settings. ·The job to be started ·The execution timing for start command
		6	Stopped by an alarm: An attempt was made to start the sub task which is stopped by an alarm.	Setting error	(1)Check the following settings. ·Alarm occurrence status
		7	Synchronization task specification of SYNC instruction omit error	Setting error	(1)Check the following settings. ·Synchronization task specification of SYNC instruction
		8	The task is specified by synchronization task of SYNC instruction.	Setting error	(1)Check the following settings. ·Synchronization task specification of SYNC instruction
		9	I/O jog being executed	Setting error	(1)Check the following settings. ·I/O jog executing status Complete the I/O jog executing status, and then restart.
		10	Separate group axis being used	Setting error	(1)Check the following settings. ·Usage status of separation use axis Complete the use of separation use axis, and then restart.
		11	The servo power supply is OFF.	Setting error	(1)Check the following settings. ·Servo power Turn ON servo power.
		12	Twin synchronous task ID error	Setting error	(1)Check the following settings. ·Twin synchronous task specification of SYNC instruction
		16	PSTART instruction is the old specification.	Setting error	(1)Check the following settings. ·The specifications of PSTART instruction Register the PSTART instruction as new specification.
		17	PWAIT instruction is the old specification.	Setting error	(1)Check the following settings. ·The specifications of PWAIT instruction Register the PWAIT instruction as new specification.
4104	WRONG EXECUTION OF LOAD INST		Sub Code1 to 245: Signifies the data transmission error.	Setting error	* Refer to the instruction manual for Data Transmission Function for details.
4105	WRONG EXECUTION OF SAVE INST		Sub Code1 to 245: Signifies the data transmission error.	Setting error	* Refer to the instruction manual for Data Transmission Function for details.

Alarm Number	Alarm Name	Sub Code	Meaning	Cause	Remedy
4106	WRONG EXECUTION OF DELETE INST		Sub Code1 to 245: Signifies the data transmission error.	Setting error	* Refer to the instruction manual for Data Transmission Function for details.
4107	OUT OF RANGE (ABS0 DATA)		Sub Code: Signifies the axis in which the alarm occurred	Setting error	(1)Check the following settings. ·Move the manipulator or station to the zero position by the axis operation and check the home position alignment marks (the arrow).
4112	DATA SENDING ERROR	1	Retry over of NAK	Communication error	(1)Reset the alarm. (2)If the alarm occurs again, check the communication setting and communication wiring is correct.
		2	Retry over for timeout in timer A	Communication error	(1)Reset the alarm. (2)If the alarm occurs again, check the communication setting and communication wiring is correct.
		3	Retry over for mutual response error	Communication error	(1)Reset the alarm. (2)If the alarm occurs again, check the communication setting and communication wiring is correct.
4113	DATA RECEIVING ERROR	1	Reception timeout (timer A)	Communication error	(1)Reset the alarm. (2)If the alarm occurs again, check the communication setting and communication wiring is correct.
		2	Reception timeout (timer B)	Communication error	(1)Reset the alarm. (2)If the alarm occurs again, check the communication setting and communication wiring is correct.
		3	Heading length is too short.	Setting error	(1)Reset the alarm. (2)If the alarm occurs again, send EOT code to release the data link and then check that the sending side data is correctly set. (3)Check that the communication setting is correct.
		4	Heading length is too long.	Setting error	(1)Reset the alarm. (2)If the alarm occurs again, send EOT code to release the data link and then check that the sending side data is correctly set. (3)Check that the communication setting is correct.
		5	The header No. error	Setting error	(1)Reset the alarm. (2)If the alarm occurs again, send EOT code to release the data link and then check that the sending side data is correctly set. (3)Check that the communication setting is correct.
		6	The text length exceeded 256 characters.	Setting error	(1)Reset the alarm. (2)If the alarm occurs again, send EOT code to release the data link and then check that the sending side data is correctly set. (3)Check that the communication setting is correct.

Alarm Number	Alarm Name	Sub Code	Meaning	Cause	Remedy
		7	Illegal data received	Setting error	(1)Reset the alarm. (2)If the alarm occurs again, send EOT code to release the data link and then check that the sending side data is correctly set. (3)Check that the communication setting is correct.
4114	TRANSMISSION HARDWARE ERROR	1	Overrun error	Communication error	(1)Reset the alarm. (2)If the alarm occurs again, check the communication setting and communication wiring is correct.
		2	Parity error	Communication error	(1)Reset the alarm. (2)If the alarm occurs again, check the communication setting and communication wiring is correct.
		3	Framing error	Communication error	(1)Reset the alarm. (2)If the alarm occurs again, check the communication setting and communication wiring is correct.
		4	Transmission timeout (timer A)	Communication error	(1)Reset the alarm. (2)If the alarm occurs again, check the communication setting and communication wiring is correct.
		5	Transmission timeout (timer B)	Communication error	(1)Reset the alarm. (2)If the alarm occurs again, check the communication setting and communication wiring is correct.
4115	TRANSMISSION SYSTEM BLOCK	1	Received EOT while waiting ACK.	Communication error	(1)Reset the alarm. (2)If the alarm occurs again, check the setting of communication or transmission side data is correctly set.
		2	Received EOT while waiting ENQ.	Communication error	(1)Reset the alarm. (2)If the alarm occurs again, check the setting of communication or transmission side data is correctly set.
		3	Received EOT before last block reception.	Communication error	(1)Reset the alarm. (2)If the alarm occurs again, check the setting of communication or transmission side data is correctly set.
		4	Received codes other than EOT after last block reception.	Communication error	(1)Reset the alarm. (2)If the alarm occurs again, check the setting of communication or transmission side data is correctly set.
4116	TRANSMISSION SYSTEM ERROR	1	Transmission data contents error	Communication error	(1)Reset the alarm. (2)If the alarm occurs again, check the setting of communication or transmission side data is correctly set.
		100	Trans error or protocol error	Communication error	(1)Reset the alarm. (2)If the alarm occurs again, check the setting of communication or transmission side data is correctly set.

Alarm Number	Alarm Name	Sub Code	Meaning	Cause	Remedy
4117	BRAKE POWER ERROR		Sub Code: XY X : Servo control board(SV#X) Y : Power-ON unit(TU#Y)	Connection failure	(1)Reset the alarm. (2)If the alarm occurs again, check the brake connection if there is a ground fault or short circuit.
				Fuse failure	(1)Reset the alarm. (2)If the alarm occurs again, turn the power OFF then back ON. (2)If the alarm occurs again, replace controller. Save the CMOS.BIN before replace controller to be safe.
4119	FAN ERROR (IN CONTROL BOX)		Sub Code 1 to 4: Signifies the Converter unit No. in which the alarm occurred	Cooling fan failure	(1)Reset the alarm. (2)If the alarm occurs again, turn the power OFF then back ON. (2)If the alarm occurs again, replace controller. Save the CMOS.BIN before replace controller to be safe.
4121	COOLING FAN1 ERROR		Sub Code: Signifies the Servo control board No. in which the alarm occurred	Cooling fan failure	Replace the cooling fan of manipulator. Check the wiring from a manipulator to a servo control board. * Move the manipulator to the safe position in the teach mode.
4122	COOLING FAN2 ERROR		Sub Code: Signifies the Servo control board No. in which the alarm occurred	Cooling fan failure	Replace the cooling fan of manipulator. Check the wiring from a manipulator to a servo control board. * Move the manipulator to the safe position in the teach mode.
4124	WRONG EXECUTION OF VISION INST	1	The specified file number is incorrect.	Setting error	(1)Check the following settings. ·File No. Specify the correct file number.
		2	The specified file set value is incorrect.	Setting error	(1)Check the following settings. ·File set value Specify the set value.
		3	Calibration could not be executed.	Setting error	(1)Check the following settings. ·The robot coordinate data or the pixel coordinate data used for the calibration ·The user variable number in the calibration file Set the robot coordinate data and the pixel coordinate data used for the calibration. Set the user variable number in the calibration file.
		4	The communication port for the vision system could not be initialized.	Setting error	(1)Check the following settings. ·The Parameter for communication port
				Connection failure	(1)Reset the alarm. (2)If the alarm occurs again, check the connection of the following cables. ·Cable between vision system and FS100 system
		5	Time-out occurred during data transmission.	Setting error	(1)Check the following settings. ·The communication setting of vision system

Alarm Number	Alarm Name	Sub Code	Meaning	Cause	Remedy
				Connection failure	(1)Reset the alarm. (2)If the alarm occurs again, check the connection of the following cables. ·Cable between vision system and FS100 system
		6	Time-out occurred during data reception.	Setting error	(1)Check the following settings. ·The communication setting of vision system
				Connection failure	(1)Reset the alarm. (2)If the alarm occurs again, check the connection of the following cables. ·Cable between vision system and FS100 system
		7	The data received from the vision system is incorrect.	Setting error	(1)Check the following settings. ·The communication setting of vision system ·The detection setting of vision system
				Connection failure	(1)Reset the alarm. (2)If the alarm occurs again, check the connection of the following cables. ·Cable between vision system and FS100 system
		8	The pixel coordinates value was not able to be converted into the robot coordinates.	Setting error	(1)Check the following settings. ·The communication setting of vision system ·Calibration file for use
		9	Failed to read or write the position type variable (P variable).	Setting error	(1)Check the following settings. ·Usage status of the specified position type variable Don't use the specified positional type variable at the same time in other jobs.
		10	Use memory is lacking and the area could not be obtained.	Software operation error occurred	(1)Reset the alarm, and then try again. (2)If the alarm occurs again, save the CMOS.BIN in maintenance mode, and then contact your Yaskawa representative about occurrence status (operating procedure).
		11	The setting value of measurement item (FT) is incorrect.		Correct the setting value of a measurement item.
		12	The data for the vision execution command is incorrect.	Software operation error occurred	(1)Reset the alarm, and then try again. (2)If the alarm occurs again, save the CMOS.BIN in maintenance mode, and then contact your Yaskawa representative about occurrence status (operating procedure).
		48	The number of waiting commands sent by Vision sensor exceeded the limit.	Software operation error occurred	(1)Reset the alarm, and then try again. (2)Check the command sent by Vision sensor (3)If the alarm occurs again, save the CMOS.BIN in maintenance mode, and then contact your Yaskawa representative about occurrence status (operating procedure).

Alarm Number	Alarm Name	Sub Code	Meaning	Cause	Remedy
4126	CANNOT EXECUTE AUTO PMT	1	System error	Software operation error occurred	(1)Reset the alarm, and then try again. (2)If the alarm occurs again, save the CMOS.BIN in maintenance mode, and then contact your Yaskawa representative about occurrence status (operating procedure).
		2	PBOX cannot be edited.	Setting error	(1)Check the following settings. ·I/O status of the edit prohibit signal The edit prohibit signal cannot input.
		3	The source job cannot be edited.	Setting error	(1)Check the following settings. ·The prohibit status of source job If the source job is protected from editing, it cannot be edited.
		4	The converted job cannot be edited.	Setting error	(1)Check the following settings. ·The prohibit status of converted job If the converted job is protected from editing, it cannot be edited.
		5	The memory area for job area is insufficient.	Software operation error occurred	(1)Reset the alarm. (2)If the error occurs again, delete unused jobs. (3)If the error occurs again after the previous measures were executed, initialize the job file in the maintenance mode, and then load the saved job file. In that case, delete the unused job. (4)If the alarm occurs again, save the CMOS.BIN in maintenance mode, and then contact your Yaskawa representative about occurrence status (operating procedure).
		6	The source job is not exist.	Setting error	(1)Check the following settings. ·Presence of the specified source job The job which does not exist cannot be set to the source job.
		7	The memory area for position data of the job is insufficient.	Software operation error occurred	(1)Reset the alarm. (2)when the error occurs again, if there is an unnecessary teaching position, delete it. (3)If the error occurs again after the previous measures were executed, initialize the job file in the maintenance mode, and then load the saved job file. In that case, delete the unuse (4)If the alarm occurs again, save the CMOS.BIN in maintenance mode, and then contact your Yaskawa representative about occurrence status (operating procedure).
		8	The job under execution is specified as the conversion job.	Setting error	(1)Check the following settings. ·Execution status of the source job ·Execution status of the converted job The job under execution is specified for the source / converted job. Execute conversion operation after ending the job execution.

Alarm Number	Alarm Name	Sub Code	Meaning	Cause	Remedy
4127	U-AXIS TIMING BELT BLOWN		Sub Code: XY X : Servo control board(SV#X) Y : Power-ON unit(TU#Y)	Belt blown	Replace the timing belt of the manipulator. Check the connection between manipulator and Servo control board. *Move the manipulator to safety place in teach mode.
4129	TWIN DRIVE OUT OF RANGE (START)		Sub Code: Corresponding master-axes and slave-axes are displayed by the bit.	Setting error	(1)Check the following settings. ·Pulse error of the master-axes and the slave-axes Switch to independent movement mode so that the pulse error of the master-axes and the slave-axes is settled within allowable range.
4130	NETWORK APPLICATION PROCESS ERROR	1	An error occurred when the notification of the APP task re-initialization was processed in the Ethernet function.	Software operation error occurred	(1)Turn the power OFF then back ON. (2)If the alarm occurs again, save the CMOS.BIN in maintenance mode, and then contact your Yaskawa representative about occurrence status (operating procedure).
				Main CPU board failure	(1)Turn the power OFF then back ON. (2)If the alarm occurs again, replace controller.
		2	An error occurred when the re-initialization response was received in the Ethernet function.	Software operation error occurred	(1)Turn the power OFF then back ON. (2)If the alarm occurs again, save the CMOS.BIN in maintenance mode, and then contact your Yaskawa representative about occurrence status (operating procedure).
				Main CPU board failure	(1)Turn the power OFF then back ON. (2)If the alarm occurs again, replace controller.
		3	The incomplete task of re-initialization was unsuccessfully completed in the Ethernet function.	Software operation error occurred	(1)Turn the power OFF then back ON. (2)If the alarm occurs again, save the CMOS.BIN in maintenance mode, and then contact your Yaskawa representative about occurrence status (operating procedure).
				Main CPU board failure	(1)Turn the power OFF then back ON. (2)If the alarm occurs again, replace controller.
		4	An error occurred when the semaphore for re-initialization was received in the Ethernet function.	Software operation error occurred	(1)Turn the power OFF then back ON. (2)If the alarm occurs again, save the CMOS.BIN in maintenance mode, and then contact your Yaskawa representative about occurrence status (operating procedure).
				Main CPU board failure	(1)Turn the power OFF then back ON. (2)If the alarm occurs again, replace controller.
		5	An error occurred when the re-initialization mail was sent in the Ethernet function.	Software operation error occurred	(1)Turn the power OFF then back ON. (2)If the alarm occurs again, save the CMOS.BIN in maintenance mode, and then contact your Yaskawa representative about occurrence status (operating procedure).
				Main CPU board failure	(1)Turn the power OFF then back ON. (2)If the alarm occurs again, replace controller.

Alarm Number	Alarm Name	Sub Code	Meaning	Cause	Remedy
		6	An error occurred in the exclusive process of the storage area control table of the Ethernet function.	Software operation error occurred	(1)Turn the power OFF then back ON. (2)If the alarm occurs again, save the CMOS.BIN in maintenance mode, and then contact your Yaskawa representative about occurrence status (operating procedure).
				Main CPU board failure	(1)Turn the power OFF then back ON. (2)If the alarm occurs again, replace controller.
		7	Time-out occurred in the re-initialization response receiving process of the Ethernet function.	Software operation error occurred	(1)Turn the power OFF then back ON. (2)If the alarm occurs again, save the CMOS.BIN in maintenance mode, and then contact your Yaskawa representative about occurrence status (operating procedure).
				Main CPU board failure	(1)Turn the power OFF then back ON. (2)If the alarm occurs again, replace controller.
		8	An error occurred in the re-initialization response receiving process of the Ethernet function.	Software operation error occurred	(1)Turn the power OFF then back ON. (2)If the alarm occurs again, save the CMOS.BIN in maintenance mode, and then contact your Yaskawa representative about occurrence status (operating procedure).
				Main CPU board failure	(1)Turn the power OFF then back ON. (2)If the alarm occurs again, replace controller.
		9	Receiving data size error occurred in the re-initialization response receiving process of the Ethernet function.	Software operation error occurred	(1)Turn the power OFF then back ON. (2)If the alarm occurs again, save the CMOS.BIN in maintenance mode, and then contact your Yaskawa representative about occurrence status (operating procedure).
				Main CPU board failure	(1)Turn the power OFF then back ON. (2)If the alarm occurs again, replace controller.
		30	An error occurred in the Web server task mail receiving process of the Ethernet function.	Software operation error occurred	(1)Turn the power OFF then back ON. (2)If the alarm occurs again, save the CMOS.BIN in maintenance mode, and then contact your Yaskawa representative about occurrence status (operating procedure).
				Main CPU board failure	(1)Turn the power OFF then back ON. (2)If the alarm occurs again, replace controller.
		31	An error occurred in the FTP server task mail receiving process of the Ethernet function.	Software operation error occurred	(1)Turn the power OFF then back ON. (2)If the alarm occurs again, save the CMOS.BIN in maintenance mode, and then contact your Yaskawa representative about occurrence status (operating procedure).
				Main CPU board failure	(1)Turn the power OFF then back ON. (2)If the alarm occurs again, replace controller.

Alarm Number	Alarm Name	Sub Code	Meaning	Cause	Remedy
		32	An error occurred in the FTP client task mail receiving process of the Ethernet function.	Software operation error occurred	(1)Turn the power OFF then back ON. (2)If the alarm occurs again, save the CMOS.BIN in maintenance mode, and then contact your Yaskawa representative about occurrence status (operating procedure).
				Main CPU board failure	(1)Turn the power OFF then back ON. (2)If the alarm occurs again, replace controller.
		40	Illegal e-mail data were received in the Web server task of the Ethernet function.	Software operation error occurred	(1)Turn the power OFF then back ON. (2)If the alarm occurs again, save the CMOS.BIN in maintenance mode, and then contact your Yaskawa representative about occurrence status (operating procedure).
				Main CPU board failure	(1)Turn the power OFF then back ON. (2)If the alarm occurs again, replace controller.
		41	Illegal e-mail data were received in the FTP server task of the Ethernet function.	Software operation error occurred	(1)Turn the power OFF then back ON. (2)If the alarm occurs again, save the CMOS.BIN in maintenance mode, and then contact your Yaskawa representative about occurrence status (operating procedure).
				Main CPU board failure	(1)Turn the power OFF then back ON. (2)If the alarm occurs again, replace controller.
		42	Illegal e-mail data were received in the FTP client task of the Ethernet function.	Software operation error occurred	(1)Turn the power OFF then back ON. (2)If the alarm occurs again, save the CMOS.BIN in maintenance mode, and then contact your Yaskawa representative about occurrence status (operating procedure).
				Main CPU board failure	(1)Turn the power OFF then back ON. (2)If the alarm occurs again, replace controller.
		50	An error occurred in the data size written to PCI of the Ethernet function.	Software operation error occurred	(1)Turn the power OFF then back ON. (2)If the alarm occurs again, save the CMOS.BIN in maintenance mode, and then contact your Yaskawa representative about occurrence status (operating procedure).
				Main CPU board failure	(1)Turn the power OFF then back ON. (2)If the alarm occurs again, replace controller.
		51	An error occurred when the request to write PCI data was received in the Ethernet function.	Software operation error occurred	(1)Turn the power OFF then back ON. (2)If the alarm occurs again, save the CMOS.BIN in maintenance mode, and then contact your Yaskawa representative about occurrence status (operating procedure).
				Main CPU board failure	(1)Turn the power OFF then back ON. (2)If the alarm occurs again, replace controller.

Alarm Number	Alarm Name	Sub Code	Meaning	Cause	Remedy
		52	The request of the undefined transmission was received in the Ethernet function.	Software operation error occurred	(1)Turn the power OFF then back ON. (2)If the alarm occurs again, save the CMOS.BIN in maintenance mode, and then contact your Yaskawa representative about occurrence status (operating procedure).
				Main CPU board failure	(1)Turn the power OFF then back ON. (2)If the alarm occurs again, replace controller.
		53	An error occurred in the transmission request of the Ethernet function.	Software operation error occurred	(1)Turn the power OFF then back ON. (2)If the alarm occurs again, save the CMOS.BIN in maintenance mode, and then contact your Yaskawa representative about occurrence status (operating procedure).
				Main CPU board failure	(1)Turn the power OFF then back ON. (2)If the alarm occurs again, replace controller.
		54	The transmission request without data was received in the Ethernet function.	Software operation error occurred	(1)Turn the power OFF then back ON. (2)If the alarm occurs again, save the CMOS.BIN in maintenance mode, and then contact your Yaskawa representative about occurrence status (operating procedure).
				Main CPU board failure	(1)Turn the power OFF then back ON. (2)If the alarm occurs again, replace controller.
		55	The transmission request of illegal data length was received in the Ethernet function.	Software operation error occurred	(1)Turn the power OFF then back ON. (2)If the alarm occurs again, save the CMOS.BIN in maintenance mode, and then contact your Yaskawa representative about occurrence status (operating procedure).
				Main CPU board failure	(1)Turn the power OFF then back ON. (2)If the alarm occurs again, replace controller.
		100	An error occurred in storing process of memory which is used in the Ethernet function.	Software operation error occurred	(1)Turn the power OFF then back ON. (2)If the alarm occurs again, save the CMOS.BIN in maintenance mode, and then contact your Yaskawa representative about occurrence status (operating procedure).
				Main CPU board failure	(1)Turn the power OFF then back ON. (2)If the alarm occurs again, replace controller.
		101	An error occurred in the buffer for request to write PCI getting process of the Ethernet function.	Software operation error occurred	(1)Turn the power OFF then back ON. (2)If the alarm occurs again, save the CMOS.BIN in maintenance mode, and then contact your Yaskawa representative about occurrence status (operating procedure).
				Main CPU board failure	(1)Turn the power OFF then back ON. (2)If the alarm occurs again, replace controller.

Alarm Number	Alarm Name	Sub Code	Meaning	Cause	Remedy
		200	The socket of the Ethernet function was full and was not able to create a socket.	Software operation error occurred	(1)Turn the power OFF then back ON. (2)If the alarm occurs again, save the CMOS.BIN in maintenance mode, and then contact your Yaskawa representative about occurrence status (operating procedure).
				Main CPU board failure	(1)Turn the power OFF then back ON. (2)If the alarm occurs again, replace controller.
		201	An error occurred in the semaphore of socket control table of the Ethernet function.	Software operation error occurred	(1)Turn the power OFF then back ON. (2)If the alarm occurs again, save the CMOS.BIN in maintenance mode, and then contact your Yaskawa representative about occurrence status (operating procedure).
				Main CPU board failure	(1)Turn the power OFF then back ON. (2)If the alarm occurs again, replace controller.
4131	UDP PROCESS ERROR	1	An error occurred in the creation of receiving socket during the UDP process of the Ethernet function.	Software operation error occurred	(1)Turn the power OFF then back ON. (2)If the alarm occurs again, save the CMOS.BIN in maintenance mode, and then contact your Yaskawa representative about occurrence status (operating procedure).
				Main CPU board failure	(1)Turn the power OFF then back ON. (2)If the alarm occurs again, replace controller.
		2	An error occurred in the creation of transmission socket during the UDP process of the Ethernet function.	Software operation error occurred	(1)Turn the power OFF then back ON. (2)If the alarm occurs again, save the CMOS.BIN in maintenance mode, and then contact your Yaskawa representative about occurrence status (operating procedure).
				Main CPU board failure	(1)Turn the power OFF then back ON. (2)If the alarm occurs again, replace controller.
		3	Illegal data were received in the UDP process of the Ethernet function.	Software operation error occurred	(1)Turn the power OFF then back ON. (2)If the alarm occurs again, save the CMOS.BIN in maintenance mode, and then contact your Yaskawa representative about occurrence status (operating procedure).
				Main CPU board failure	(1)Turn the power OFF then back ON. (2)If the alarm occurs again, replace controller.
		4	Transmission error occurred in the UDP process of the Ethernet function.	Software operation error occurred	(1)Turn the power OFF then back ON. (2)If the alarm occurs again, save the CMOS.BIN in maintenance mode, and then contact your Yaskawa representative about occurrence status (operating procedure).
				Main CPU board failure	(1)Turn the power OFF then back ON. (2)If the alarm occurs again, replace controller.

Alarm Number	Alarm Name	Sub Code	Meaning	Cause	Remedy
		5	The SELECT operation was not successfully completed in the UDP process of the Ethernet function.	Software operation error occurred	(1)Turn the power OFF then back ON. (2)If the alarm occurs again, save the CMOS.BIN in maintenance mode, and then contact your Yaskawa representative about occurrence status (operating procedure).
				Main CPU board failure	(1)Turn the power OFF then back ON. (2)If the alarm occurs again, replace controller.
		100	The re-initialization notification of illegal data length was received in the UDP process of the Ethernet function.	Software operation error occurred	(1)Turn the power OFF then back ON. (2)If the alarm occurs again, save the CMOS.BIN in maintenance mode, and then contact your Yaskawa representative about occurrence status (operating procedure).
				Main CPU board failure	(1)Turn the power OFF then back ON. (2)If the alarm occurs again, replace controller.
		101	The re-initialization notification of illegal data was received in the UDP process of the Ethernet function.	Software operation error occurred	(1)Turn the power OFF then back ON. (2)If the alarm occurs again, save the CMOS.BIN in maintenance mode, and then contact your Yaskawa representative about occurrence status (operating procedure).
				Main CPU board failure	(1)Turn the power OFF then back ON. (2)If the alarm occurs again, replace controller.
		102	The PCI write process was not successfully completed in the UDP process of the Ethernet function.	Software operation error occurred	(1)Turn the power OFF then back ON. (2)If the alarm occurs again, save the CMOS.BIN in maintenance mode, and then contact your Yaskawa representative about occurrence status (operating procedure).
				Main CPU board failure	(1)Turn the power OFF then back ON. (2)If the alarm occurs again, replace controller.
		103	The transmission request of illegal data length was received in the UDP process of the Ethernet function.	Software operation error occurred	(1)Turn the power OFF then back ON. (2)If the alarm occurs again, save the CMOS.BIN in maintenance mode, and then contact your Yaskawa representative about occurrence status (operating procedure).
				Main CPU board failure	(1)Turn the power OFF then back ON. (2)If the alarm occurs again, replace controller.
		104	The transmission request of illegal data was received in the UDP process of the Ethernet function.	Software operation error occurred	(1)Turn the power OFF then back ON. (2)If the alarm occurs again, save the CMOS.BIN in maintenance mode, and then contact your Yaskawa representative about occurrence status (operating procedure).
				Main CPU board failure	(1)Turn the power OFF then back ON. (2)If the alarm occurs again, replace controller.

Alarm Number	Alarm Name	Sub Code	Meaning	Cause	Remedy
4132	TCP PROCESS ERROR	1	The socket table was not successfully created in the TCP process of the Ethernet function.	Software operation error occurred	(1)Turn the power OFF then back ON. (2)If the alarm occurs again, save the CMOS.BIN in maintenance mode, and then contact your Yaskawa representative about occurrence status (operating procedure).
				Main CPU board failure	(1)Turn the power OFF then back ON. (2)If the alarm occurs again, replace controller.
		2	An error occurred in the process of the TCP server initialization of the Ethernet function.	Software operation error occurred	(1)Turn the power OFF then back ON. (2)If the alarm occurs again, save the CMOS.BIN in maintenance mode, and then contact your Yaskawa representative about occurrence status (operating procedure).
				Main CPU board failure	(1)Turn the power OFF then back ON. (2)If the alarm occurs again, replace controller.
		3	An error occurred in connection detecting process of TCP server of the Ethernet function.	Software operation error occurred	(1)Turn the power OFF then back ON. (2)If the alarm occurs again, save the CMOS.BIN in maintenance mode, and then contact your Yaskawa representative about occurrence status (operating procedure).
				Main CPU board failure	(1)Turn the power OFF then back ON. (2)If the alarm occurs again, replace controller.
		4	An error occurred in the connection detection checking process of TCP server of the Ethernet function.	Software operation error occurred	(1)Turn the power OFF then back ON. (2)If the alarm occurs again, save the CMOS.BIN in maintenance mode, and then contact your Yaskawa representative about occurrence status (operating procedure).
				Main CPU board failure	(1)Turn the power OFF then back ON. (2)If the alarm occurs again, replace controller.
4134	COOLING FAN SET ABNORMAL	0		Setting error	(1)Check the following settings. ·Confirm parameter SVS and S2C for the cooling fan. ·Open the front panel to refer to the parameter list on the back.
4137	WRONG EXECUTION OF SETUALM INST	1	Alarm code specification error	Setting error	(1)Check the following settings. ·Alarm code Specify the alarm in the range 8000 to 8999.
		2	Task specification error	Setting error	(1)Check the following settings. ·Task specification Specify the task in the range 0 to 4 (7 at expansion).
		3	Motion mode specification error	Setting error	(1)Check the following settings. ·Motion mode specification Set the motion mode to 0 or 1.

Alarm Number	Alarm Name	Sub Code	Meaning	Cause	Remedy
4138	WRONG EXECUTION OF SVON INST			Connection failure	(1)Check the following settings. ·Short-circuit the external servo ON (EXSVON) of MXT terminal block.
				Setting error	(1)Check the following settings. ·The concurrent I/O signal #80031 (servo ON condition1) ON ·The concurrent I/O signal #80033 (servo ON condition2) ON
4139	WRONG EXECUTION OF PRINT INST			Setting error	(1)Check the following settings. ·The setting of the PRINT output conversion spec (character string specification) If there is no problem in the setting, delete the corresponding PRINT instruction and register again.
4140	WRONG EXECUTION OF DIALOG INST	1	DIALOG instruction control error	Setting error	(1)Check the following settings. ·The tag setting of DIALOG instruction If no fault is found, delete corresponding DIALOG instruction, and then register again.
		2	Messages and buttons are not registered.	Setting error	(1)Check the following settings. ·The information of DIALOG instruction message and button
		3	Buttons are not registered.	Setting error	(1)Check the following settings. ·The information of DIALOG instruction button
4144	FIELD BUS BOARD STATUS ERROR		In fieldbus board slot is displayed in the sub-code, any board error, communication error (it detects communication error), or Un-communicating slave (it detects the slave station can not communicate) occurs.	Setting error	(1)Check the following settings. · Check the IO module configuration of the corresponding fieldbus board in maintenance mode. · Check the switch settings on the corresponding fieldbus board. · Check the settings of the device to communicate with the corresponding fieldbus board.
				Connection failure	(1)Reset the alarm. (2)If the alarm occurs again, check the connection and inserting state of the following cables and connectors. · Communication connector and communication cable of the corresponding fieldbus board. · Communication connector and communication cable of the device that communicates with corresponding fieldbus board.
				Fieldbus board failure	(1)Turn the power OFF then back ON. (2)If the alarm occurs again, replace the following board. Save the CMOS.BIN before replace the board to be safe. · Corresponding fieldbus board
				Main CPU board failure	(1)Turn the power OFF then back ON. (2)If the alarm occurs again, replace the CPU-201R board.

Alarm Number	Alarm Name	Sub Code	Meaning	Cause	Remedy
4152	TIMING BELT BLOWN		Servo control board number (SV#) from which an error was detected.	Manipulator timing belt is blown.	Move the manipulator in teach mode to the position where there is no torque on the driving belt. (1) Check the timing belt tension.
4200	SYSTEM ERROR (FILE DATA)		Sub code 01 to 50: Signifies the internal software error	Data error	(1)Reset the alarm. (2)If the alarm occurs again, turn the controller power OFF and then ON to check the operation. (3)If the alarm occurs again, initialize the appropriate data in maintenance mode, and then load the data saved in the external memory device.
4201	SYSTEM ERROR (JOB)	-1	An error occurred during the access to a job in parameter specifications.	Software operation error occurred	(1)Reset the alarm, and then try again. (2)If the alarm occurs again, save the CMOS.BIN in maintenance mode, and then contact your Yaskawa representative about occurrence status (operating procedure).
				Main CPU board failure	(1)Reset the alarm, and then try again. (2)If the alarm occurs again, replace controller. Save the CMOS.BIN before replace controller to be safe.
		-3	The access to a job could not be performed with the specified job name.	Software operation error occurred	(1)Reset the alarm, and then try again. (2)If the alarm occurs again, save the CMOS.BIN in maintenance mode, and then contact your Yaskawa representative about occurrence status (operating procedure).
				Main CPU board failure	(1)Reset the alarm, and then try again. (2)If the alarm occurs again, replace controller. Save the CMOS.BIN before replace controller to be safe.
		-4	A job was newly created with the same name of the job already specified in the memory.	Software operation error occurred	(1)Reset the alarm, and then try again. (2)If the alarm occurs again, save the CMOS.BIN in maintenance mode, and then contact your Yaskawa representative about occurrence status (operating procedure).
				Main CPU board failure	(1)Reset the alarm, and then try again. (2)If the alarm occurs again, replace controller. Save the CMOS.BIN before replace controller to be safe.
		-5	A job was newly created with the same name of the job already specified in the memory.	Software operation error occurred	(1)Reset the alarm, and then try again. (2)If the alarm occurs again, save the CMOS.BIN in maintenance mode, and then contact your Yaskawa representative about occurrence status (operating procedure).
				Main CPU board failure	(1)Reset the alarm, and then try again. (2)If the alarm occurs again, replace controller. Save the CMOS.BIN before replace controller to be safe.
		-6	The allowable job registration area (memory) was exceeded.	Setting error	(1)Check the following settings. ·Delete unused jobs.

Alarm Number	Alarm Name	Sub Code	Meaning	Cause	Remedy
		-7	A job that did not exist in the memory was specified.	Software operation error occurred	(1)Reset the alarm, and then try again. (2)If the alarm occurs again, save the CMOS.BIN in maintenance mode, and then contact your Yaskawa representative about occurrence status (operating procedure).
				Main CPU board failure	(1)Reset the alarm, and then try again. (2)If the alarm occurs again, replace controller. Save the CMOS.BIN before replace controller to be safe.
		-8	An attempt was made to change the contents for the job prohibited from being edited.	Setting error	(1)Check the following settings. ·Release the prohibition.
		-9	An error occurred during the access to a job in handle value.	Software operation error occurred	(1)Reset the alarm, and then try again. (2)If the alarm occurs again, save the CMOS.BIN in maintenance mode, and then contact your Yaskawa representative about occurrence status (operating procedure).
				Main CPU board failure	(1)Reset the alarm, and then try again. (2)If the alarm occurs again, replace controller. Save the CMOS.BIN before replace controller to be safe.
		-10	An error occurred in job data control system.	Software operation error occurred	(1)Reset the alarm, and then try again. (2)If the alarm occurs again, save the CMOS.BIN in maintenance mode, and then contact your Yaskawa representative about occurrence status (operating procedure).
				Main CPU board failure	(1)Reset the alarm, and then try again. (2)If the alarm occurs again, replace controller. Save the CMOS.BIN before replace controller to be safe.
		-11	An error occurred in sequence number of the accessed job.	Software operation error occurred	(1)Reset the alarm, and then try again. (2)If the alarm occurs again, save the CMOS.BIN in maintenance mode, and then contact your Yaskawa representative about occurrence status (operating procedure).
				Main CPU board failure	(1)Reset the alarm, and then try again. (2)If the alarm occurs again, replace controller. Save the CMOS.BIN before replace controller to be safe.
		-12	An error occurred in step number of the accessed job.	Software operation error occurred	(1)Reset the alarm, and then try again. (2)If the alarm occurs again, save the CMOS.BIN in maintenance mode, and then contact your Yaskawa representative about occurrence status (operating procedure).
				Main CPU board failure	(1)Reset the alarm, and then try again. (2)If the alarm occurs again, replace controller. Save the CMOS.BIN before replace controller to be safe.

Alarm Number	Alarm Name	Sub Code	Meaning	Cause	Remedy
		-13	A job specified at job search did not exist in the memory.	Software operation error occurred	(1)Reset the alarm, and then try again. (2)If the alarm occurs again, save the CMOS.BIN in maintenance mode, and then contact your Yaskawa representative about occurrence status (operating procedure).
				Main CPU board failure	(1)Reset the alarm, and then try again. (2)If the alarm occurs again, replace controller. Save the CMOS.BIN before replace controller to be safe.
		-16	Unused handles were lacking when an attempt was made to open a job.	Software operation error occurred	(1)Reset the alarm, and then try again. (2)If the alarm occurs again, save the CMOS.BIN in maintenance mode, and then contact your Yaskawa representative about occurrence status (operating procedure).
				Main CPU board failure	(1)Reset the alarm, and then try again. (2)If the alarm occurs again, replace controller. Save the CMOS.BIN before replace controller to be safe.
		-18	The number of instructions added to a job exceeded 9999.	Setting error	(1)Check the following settings. ·Delete unnecessary instructions and add new instructions again.
		-19	The number of steps added to a job exceeded 999.	Setting error	(1)Check the following settings. Delete unnecessary steps and add new steps again.
		-22	Job information was not able to be expanded.	Software operation error occurred	(1)Reset the alarm, and then try again. (2)If the alarm occurs again, save the CMOS.BIN in maintenance mode, and then contact your Yaskawa representative about occurrence status (operating procedure).
				Main CPU board failure	(1)Reset the alarm, and then try again. (2)If the alarm occurs again, replace controller. Save the CMOS.BIN before replace controller to be safe.
		-23	Job information was not able to be acquired.	Software operation error occurred	(1)Reset the alarm, and then try again. (2)If the alarm occurs again, save the CMOS.BIN in maintenance mode, and then contact your Yaskawa representative about occurrence status (operating procedure).
				Main CPU board failure	(1)Reset the alarm, and then try again. (2)If the alarm occurs again, replace controller. Save the CMOS.BIN before replace controller to be safe.
		-24	An error occurred in cluster control.	Software operation error occurred	(1)Reset the alarm, and then try again. (2)If the alarm occurs again, save the CMOS.BIN in maintenance mode, and then contact your Yaskawa representative about occurrence status (operating procedure).

Alarm Number	Alarm Name	Sub Code	Meaning	Cause	Remedy
				Main CPU board failure	(1)Reset the alarm, and then try again. (2)If the alarm occurs again, replace controller. Save the CMOS.BIN before replace controller to be safe.
		-25	Failed to read the cluster information.	Software operation error occurred	(1)Reset the alarm, and then try again. (2)If the alarm occurs again, save the CMOS.BIN in maintenance mode, and then contact your Yaskawa representative about occurrence status (operating procedure).
				Main CPU board failure	(1)Reset the alarm, and then try again. (2)If the alarm occurs again, replace controller. Save the CMOS.BIN before replace controller to be safe.
		-26	Heap area could not be obtained.	Software operation error occurred	(1)Reset the alarm, and then try again. (2)If the alarm occurs again, save the CMOS.BIN in maintenance mode, and then contact your Yaskawa representative about occurrence status (operating procedure).
				Main CPU board failure	(1)Reset the alarm, and then try again. (2)If the alarm occurs again, replace controller. Save the CMOS.BIN before replace controller to be safe.
		-90	The configuration data is damaged.	Software operation error occurred	(1)Reset the alarm, and then try again. (2)If the alarm occurs again, save the CMOS.BIN in maintenance mode, and then contact your Yaskawa representative about occurrence status (operating procedure).
				Main CPU board failure	(1)Reset the alarm, and then try again. (2)If the alarm occurs again, replace controller. Save the CMOS.BIN before replace controller to be safe.
		-91	The FAT area is damaged.	Software operation error occurred	(1)Reset the alarm, and then try again. (2)If the alarm occurs again, save the CMOS.BIN in maintenance mode, and then contact your Yaskawa representative about occurrence status (operating procedure).
				Main CPU board failure	(1)Reset the alarm, and then try again. (2)If the alarm occurs again, replace controller. Save the CMOS.BIN before replace controller to be safe.
		-92	A job data in the memory was destroyed.	Software operation error occurred	(1)Reset the alarm, and then try again. (2)If the alarm occurs again, save the CMOS.BIN in maintenance mode, and then contact your Yaskawa representative about occurrence status (operating procedure).
				Main CPU board failure	(1)Reset the alarm, and then try again. (2)If the alarm occurs again, replace controller. Save the CMOS.BIN before replace controller to be safe.

Alarm Number	Alarm Name	Sub Code	Meaning	Cause	Remedy
4202	SYSTEM ERROR (JOB)	1	An error occurred in parameter specifications for the access to a job.	Software operation error occurred	(1)Reset the alarm. (2)If the error occurs again, delete the job where the alarm occurred. (3)If the error occurs again after the previous measures were executed, initialize the job file in the maintenance mode, and then load the saved job file. (4)If the alarm occurs again, save the CMOS.BIN in maintenance mode, and then contact your Yaskawa representative about occurrence status (operating procedure).
		2	Access time exceeded the limit during the access to a job.	Software operation error occurred	(1)Reset the alarm. (2)If the error occurs again, delete the job where the alarm occurred. (3)If the error occurs again after the previous measures were executed, initialize the job file in the maintenance mode, and then load the saved job file. (4)If the alarm occurs again, save the CMOS.BIN in maintenance mode, and then contact your Yaskawa representative about occurrence status (operating procedure).
		3	Unapproved characters are used for a job name.	Software operation error occurred	(1)Reset the alarm. (2)If the error occurs again, delete the job where the alarm occurred. (3)If the error occurs again after the previous measures were executed, initialize the job file in the maintenance mode, and then load the saved job file. (4)If the alarm occurs again, save the CMOS.BIN in maintenance mode, and then contact your Yaskawa representative about occurrence status (operating procedure).
		4	A job was newly created with the same name of the job already specified in the memory.	Software operation error occurred	(1)Reset the alarm. (2)If the error occurs again, delete the job where the alarm occurred. (3)If the error occurs again after the previous measures were executed, initialize the job file in the maintenance mode, and then load the saved job file. (4)If the alarm occurs again, save the CMOS.BIN in maintenance mode, and then contact your Yaskawa representative about occurrence status (operating procedure).
		5	A job was newly created with the same name of the job already specified in the memory.	Software operation error occurred	(1)Reset the alarm. (2)If the error occurs again, delete the job where the alarm occurred. (3)If the error occurs again after the previous measures were executed, initialize the job file in the maintenance mode, and then load the saved job file. (4)If the alarm occurs again, save the CMOS.BIN in maintenance mode, and then contact your Yaskawa representative about occurrence status (operating procedure).

Alarm Number	Alarm Name	Sub Code	Meaning	Cause	Remedy
		6	The allowable job registration area (memory) was exceeded.	Software operation error occurred	(1)Reset the alarm. (2)If the error occurs again, delete unused jobs. (3)If the error occurs again after the previous measures were executed, initialize the job file in the maintenance mode, and then load the saved job file. In that case, delete the unused job. (4)If the alarm occurs again, save the CMOS.BIN in maintenance mode, and then contact your Yaskawa representative about occurrence status (operating procedure).
		7	A job that did not exist in the memory was specified.	Software operation error occurred	(1)Reset the alarm. (2)If the error occurs again, delete the job where the alarm occurred. (3)If the error occurs again after the previous measures were executed, initialize the job file in the maintenance mode, and then load the saved job file. (4)If the alarm occurs again, save the CMOS.BIN in maintenance mode, and then contact your Yaskawa representative about occurrence status (operating procedure).
		8	An attempt was made to change the contents for the job prohibited from being edited.	Setting error	(1)Check the following settings. -Setting of EDIT LOCK in JOB header screen If the job is protected from editing, release the prohibition.
				Software operation error occurred	(1)Reset the alarm. (2)If you edit this job, release the prohibition. (3)If the error occurs again, delete the job where the alarm occurred. (4)If the error occurs again after the previous measures were executed, initialize the job file in the maintenance mode, and then load the saved job file. (5)If the alarm occurs again, save the CMOS.BIN in maintenance mode, and then contact your Yaskawa representative about occurrence status (operating procedure).
		9	An attempt was made to change the contents for the job prohibited from being edited.	Setting error	(1)Check the following settings. -Setting of EDIT LOCK in JOB header screen If the job is protected from editing, release the prohibition.
				Software operation error occurred	(1)Reset the alarm. (2)If you edit this job, release the prohibition. (3)If the error occurs again, delete the job where the alarm occurred. (4)If the error occurs again after the previous measures were executed, initialize the job file in the maintenance mode, and then load the saved job file. (5)If the alarm occurs again, save the CMOS.BIN in maintenance mode, and then contact your Yaskawa representative about occurrence status (operating procedure).

Alarm Number	Alarm Name	Sub Code	Meaning	Cause	Remedy
		10	An error occurred in job data control system.	Software operation error occurred	(1)Reset the alarm. (2)If the error occurs again, delete the job where the alarm occurred. (3)If the error occurs again after the previous measures were executed, initialize the job file in the maintenance mode, and then load the saved job file. (4)If the alarm occurs again, save the CMOS.BIN in maintenance mode, and then contact your Yaskawa representative about occurrence status (operating procedure).
		11	An error occurred in sequence number of the accessed job.	Software operation error occurred	(1)Reset the alarm. (2)If the error occurs again, delete the job where the alarm occurred. (3)If the error occurs again after the previous measures were executed, initialize the job file in the maintenance mode, and then load the saved job file. (4)If the alarm occurs again, save the CMOS.BIN in maintenance mode, and then contact your Yaskawa representative about occurrence status (operating procedure).
		12	An error occurred in step number of the accessed job.	Software operation error occurred	(1)Reset the alarm. (2)If the error occurs again, delete the job where the alarm occurred. (3)If the error occurs again after the previous measures were executed, initialize the job file in the maintenance mode, and then load the saved job file. (4)If the alarm occurs again, save the CMOS.BIN in maintenance mode, and then contact your Yaskawa representative about occurrence status (operating procedure).
		13	A job specified at job search did not exist in the memory.	Software operation error occurred	(1)Reset the alarm. (2)If the error occurs again, delete the job where the alarm occurred. (3)If the error occurs again after the previous measures were executed, initialize the job file in the maintenance mode, and then load the saved job file. (4)If the alarm occurs again, save the CMOS.BIN in maintenance mode, and then contact your Yaskawa representative about occurrence status (operating procedure).
		14	There was an instruction that did not exist in a job because of inconsistency of the system software.	Software operation error occurred	(1)Reset the alarm. (2)If the error occurs again, delete the job where the alarm occurred. (3)If the error occurs again after the previous measures were executed, initialize the job file in the maintenance mode, and then load the saved job file. (4)If the alarm occurs again, save the CMOS.BIN in maintenance mode, and then contact your Yaskawa representative about occurrence status (operating procedure).
		16	Unused handles were lacking when an attempt was made to open a job.	Setting error	(1)Check the following settings. ·The number of call job stacks Set the job configuration that decreases the number of call job stacks.

Alarm Number	Alarm Name	Sub Code	Meaning	Cause	Remedy
				Software operation error occurred	(1)Reset the alarm. (2)If the error occurs again, delete the job where the alarm occurred. (3)If the error occurs again after the previous measures were executed, initialize the job file in the maintenance mode, and then load the saved job file. (4)If the alarm occurs again, save the CMOS.BIN in maintenance mode, and then contact your Yaskawa representative about occurrence status (operating procedure).
		18	The number of instructions added to a job exceeded 9999.	Setting error	(1)Check the following settings. ·The number of steps in job Delete unnecessary instructions in job and add new instructions.
				Software operation error occurred	(1)Reset the alarm. (2)If the error occurs again, delete the job where the alarm occurred. (3)If the error occurs again after the previous measures were executed, initialize the job file in the maintenance mode, and then load the saved job file. (4)If the alarm occurs again, save the CMOS.BIN in maintenance mode, and then contact your Yaskawa representative about occurrence status (operating procedure).
		19	The number of steps added to a job exceeded 9999.	Setting error	(1)Check the following settings. ·The number of steps in job Delete unnecessary steps in job and add new steps.
				Software operation error occurred	(1)Reset the alarm. (2)If the error occurs again, delete the job where the alarm occurred. (3)If the error occurs again after the previous measures were executed, initialize the job file in the maintenance mode, and then load the saved job file. (4)If the alarm occurs again, save the CMOS.BIN in maintenance mode, and then contact your Yaskawa representative about occurrence status (operating procedure).
		20	A job was newly created with the same name of the undefined job already specified in the memory.	Software operation error occurred	(1)Reset the alarm. (2)If the error occurs again, delete the job where the alarm occurred. (3)If the error occurs again after the previous measures were executed, initialize the job file in the maintenance mode, and then load the saved job file. (4)If the alarm occurs again, save the CMOS.BIN in maintenance mode, and then contact your Yaskawa representative about occurrence status (operating procedure).

Alarm Number	Alarm Name	Sub Code	Meaning	Cause	Remedy
		22	Failed to expand job information during the access to a job.	Software operation error occurred	(1)Reset the alarm. (2)If the error occurs again, delete the job where the alarm occurred. (3)If the error occurs again after the previous measures were executed, initialize the job file in the maintenance mode, and then load the saved job file. (4)If the alarm occurs again, save the CMOS.BIN in maintenance mode, and then contact your Yaskawa representative about occurrence status (operating procedure).
		23	The accessed job was not opened.	Software operation error occurred	(1)Reset the alarm. (2)If the error occurs again, delete the job where the alarm occurred. (3)If the error occurs again after the previous measures were executed, initialize the job file in the maintenance mode, and then load the saved job file. (4)If the alarm occurs again, save the CMOS.BIN in maintenance mode, and then contact your Yaskawa representative about occurrence status (operating procedure).
		24	An error occurred in the cluster control process of the accessed job.	Software operation error occurred	(1)Reset the alarm. (2)If the error occurs again, delete the job where the alarm occurred. (3)If the error occurs again after the previous measures were executed, initialize the job file in the maintenance mode, and then load the saved job file. (4)If the alarm occurs again, save the CMOS.BIN in maintenance mode, and then contact your Yaskawa representative about occurrence status (operating procedure).
		25	An error occurred when reading the cluster information of the accessed job.	Software operation error occurred	(1)Reset the alarm. (2)If the error occurs again, delete the job where the alarm occurred. (3)If the error occurs again after the previous measures were executed, initialize the job file in the maintenance mode, and then load the saved job file. (4)If the alarm occurs again, save the CMOS.BIN in maintenance mode, and then contact your Yaskawa representative about occurrence status (operating procedure).
		26	Failed to acquire the necessary memory area during the access to a job.	Software operation error occurred	(1)Reset the alarm. (2)If the error occurs again, delete the job where the alarm occurred. (3)If the error occurs again after the previous measures were executed, initialize the job file in the maintenance mode, and then load the saved job file. (4)If the alarm occurs again, save the CMOS.BIN in maintenance mode, and then contact your Yaskawa representative about occurrence status (operating procedure).

Alarm Number	Alarm Name	Sub Code	Meaning	Cause	Remedy
		90	The configuration information for job data control is damaged.	Software operation error occurred	(1)Reset the alarm. (2)If the error occurs again, delete the job where the alarm occurred. (3)If the error occurs again after the previous measures were executed, initialize the job file in the maintenance mode, and then load the saved job file. (4)If the alarm occurs again, save the CMOS.BIN in maintenance mode, and then contact your Yaskawa representative about occurrence status (operating procedure).
		91	The FAT information for job data is damaged.	Software operation error occurred	(1)Reset the alarm. (2)If the error occurs again, delete the job where the alarm occurred. (3)If the error occurs again after the previous measures were executed, initialize the job file in the maintenance mode, and then load the saved job file. (4)If the alarm occurs again, save the CMOS.BIN in maintenance mode, and then contact your Yaskawa representative about occurrence status (operating procedure).
		92	A job data was destroyed.	Software operation error occurred	(1)Reset the alarm. (2)If the error occurs again, delete the job where the alarm occurred. (3)If the error occurs again after the previous measures were executed, initialize the job file in the maintenance mode, and then load the saved job file. (4)If the alarm occurs again, save the CMOS.BIN in maintenance mode, and then contact your Yaskawa representative about occurrence status (operating procedure).
		99	A job data in the memory was destroyed.	Software operation error occurred	(1)Reset the alarm. (2)If the error occurs again, delete the job where the alarm occurred. (3)If the error occurs again after the previous measures were executed, initialize the job file in the maintenance mode, and then load the saved job file. (4)If the alarm occurs again, save the CMOS.BIN in maintenance mode, and then contact your Yaskawa representative about occurrence status (operating procedure).
4203	SYSTEM ERROR (POSITION DATA)	-1	The memory area for position data is lacking at the initialization of the position data control process.	Software operation error occurred	(1)Reset the alarm, and then try again. (2)If the alarm occurs again, save the CMOS.BIN in maintenance mode, and then contact your Yaskawa representative about occurrence status (operating procedure).
				Main CPU board failure	(1)Reset the alarm, and then try again. (2)If the alarm occurs again, replace controller. Save the CMOS.BIN before replace controller to be safe.
		-3	The number of axes for position data is zero.	Software operation error occurred	(1)Reset the alarm, and then try again. (2)If the alarm occurs again, save the CMOS.BIN in maintenance mode, and then contact your Yaskawa representative about occurrence status (operating procedure).

Alarm Number	Alarm Name	Sub Code	Meaning	Cause	Remedy
				Main CPU board failure	(1)Reset the alarm, and then try again. (2)If the alarm occurs again, replace controller. Save the CMOS.BIN before replace controller to be safe.
		-6	Unused position data file is destroyed.	Software operation error occurred	(1)Reset the alarm, and then try again. (2)If the alarm occurs again, save the CMOS.BIN in maintenance mode, and then contact your Yaskawa representative about occurrence status (operating procedure).
				Main CPU board failure	(1)Reset the alarm, and then try again. (2)If the alarm occurs again, replace controller. Save the CMOS.BIN before replace controller to be safe.
		-7	Unused position data file does not exist.	Software operation error occurred	(1)Reset the alarm, and then try again. (2)If the alarm occurs again, save the CMOS.BIN in maintenance mode, and then contact your Yaskawa representative about occurrence status (operating procedure).
				Main CPU board failure	(1)Reset the alarm, and then try again. (2)If the alarm occurs again, replace controller. Save the CMOS.BIN before replace controller to be safe.
		-8	Position data file is destroyed.	Software operation error occurred	(1)Reset the alarm, and then try again. (2)If the alarm occurs again, save the CMOS.BIN in maintenance mode, and then contact your Yaskawa representative about occurrence status (operating procedure).
				Main CPU board failure	(1)Reset the alarm, and then try again. (2)If the alarm occurs again, replace controller. Save the CMOS.BIN before replace controller to be safe.
		-9	Position data control information is destroyed.	Software operation error occurred	(1)Reset the alarm, and then try again. (2)If the alarm occurs again, save the CMOS.BIN in maintenance mode, and then contact your Yaskawa representative about occurrence status (operating procedure).
				Main CPU board failure	(1)Reset the alarm, and then try again. (2)If the alarm occurs again, replace controller. Save the CMOS.BIN before replace controller to be safe.
		-10	An error occurred in specified position data number.	Software operation error occurred	(1)Reset the alarm, and then try again. (2)If the alarm occurs again, save the CMOS.BIN in maintenance mode, and then contact your Yaskawa representative about occurrence status (operating procedure).
				Main CPU board failure	(1)Reset the alarm, and then try again. (2)If the alarm occurs again, replace controller. Save the CMOS.BIN before replace controller to be safe.

Alarm Number	Alarm Name	Sub Code	Meaning	Cause	Remedy
		-11	Position data is not registered.	Software operation error occurred	(1)Reset the alarm, and then try again. (2)If the alarm occurs again, save the CMOS.BIN in maintenance mode, and then contact your Yaskawa representative about occurrence status (operating procedure).
				Main CPU board failure	(1)Reset the alarm, and then try again. (2)If the alarm occurs again, replace controller. Save the CMOS.BIN before replace controller to be safe.
		-12	An attempt was made to access the undefined position data.	Software operation error occurred	(1)Reset the alarm, and then try again. (2)If the alarm occurs again, save the CMOS.BIN in maintenance mode, and then contact your Yaskawa representative about occurrence status (operating procedure).
				Main CPU board failure	(1)Reset the alarm, and then try again. (2)If the alarm occurs again, replace controller. Save the CMOS.BIN before replace controller to be safe.
		-13	An attempt was made to access the position data for the undefined control group.	Software operation error occurred	(1)Reset the alarm, and then try again. (2)If the alarm occurs again, save the CMOS.BIN in maintenance mode, and then contact your Yaskawa representative about occurrence status (operating procedure).
				Main CPU board failure	(1)Reset the alarm, and then try again. (2)If the alarm occurs again, replace controller. Save the CMOS.BIN before replace controller to be safe.
		-20	Inconsistency of data.	Software operation error occurred	(1)Reset the alarm, and then try again. (2)If the alarm occurs again, save the CMOS.BIN in maintenance mode, and then contact your Yaskawa representative about occurrence status (operating procedure).
				Main CPU board failure	(1)Reset the alarm, and then try again. (2)If the alarm occurs again, replace controller. Save the CMOS.BIN before replace controller to be safe.
4204	SYSTEM ERROR (POSITION DATA)	1	The number of axes for all the control groups is zero at the initialization of the position data control process	Software operation error occurred	(1)Reset the alarm. (2)If the error occurs again, delete the job where the alarm occurred. (3)If the error occurs again after the previous measures were executed, initialize the job file in the maintenance mode, and then load the saved job file. (4)If the alarm occurs again, save the CMOS.BIN in maintenance mode, and then contact your Yaskawa representative about occurrence status (operating procedure).

Alarm Number	Alarm Name	Sub Code	Meaning	Cause	Remedy
		3	The number of axes for position data is zero.	Software operation error occurred	(1)Reset the alarm. (2)If the error occurs again, delete the job where the alarm occurred. (3)If the error occurs again after the previous measures were executed, initialize the job file in the maintenance mode, and then load the saved job file. (4)If the alarm occurs again, save the CMOS.BIN in maintenance mode, and then contact your Yaskawa representative about occurrence status (operating procedure).
		6	Unused position data file is destroyed.	Software operation error occurred	(1)Reset the alarm. (2)If the error occurs again, delete the job where the alarm occurred. (3)If the error occurs again after the previous measures were executed, initialize the job file in the maintenance mode, and then load the saved job file. (4)If the alarm occurs again, save the CMOS.BIN in maintenance mode, and then contact your Yaskawa representative about occurrence status (operating procedure).
		7	Unused position data file does not exist.	Setting error	(1)Check the following settings. ·The number of steps in job (position data) Delete unnecessary position data in job and add new position data.
				Software operation error occurred	(1)Reset the alarm. (2)If the error occurs again, delete the job where the alarm occurred. (3)If the error occurs again after the previous measures were executed, initialize the job file in the maintenance mode, and then load the saved job file. (4)If the alarm occurs again, save the CMOS.BIN in maintenance mode, and then contact your Yaskawa representative about occurrence status (operating procedure).
		8	Position data file is destroyed.	Software operation error occurred	(1)Reset the alarm. (2)If the error occurs again, delete the job where the alarm occurred. (3)If the error occurs again after the previous measures were executed, initialize the job file in the maintenance mode, and then load the saved job file. (4)If the alarm occurs again, save the CMOS.BIN in maintenance mode, and then contact your Yaskawa representative about occurrence status (operating procedure).
		9	Position data control information is destroyed.	Software operation error occurred	(1)Reset the alarm. (2)If the error occurs again, delete the job where the alarm occurred. (3)If the error occurs again after the previous measures were executed, initialize the job file in the maintenance mode, and then load the saved job file. (4)If the alarm occurs again, save the CMOS.BIN in maintenance mode, and then contact your Yaskawa representative about occurrence status (operating procedure).

Alarm Number	Alarm Name	Sub Code	Meaning	Cause	Remedy
		10	An error occurred in specified position data number.	Software operation error occurred	(1)Reset the alarm. (2)If the error occurs again, delete the job where the alarm occurred. (3)If the error occurs again after the previous measures were executed, initialize the job file in the maintenance mode, and then load the saved job file. (4)If the alarm occurs again, save the CMOS.BIN in maintenance mode, and then contact your Yaskawa representative about occurrence status (operating procedure).
		11	Position data is not registered.	Setting error	(1)Check the following settings. ·Teaching of alarm occurred point Teaching the point where alarm occurred.
				Software operation error occurred	(1)Reset the alarm. (2)If the error occurs again, delete the job where the alarm occurred. (3)If the error occurs again after the previous measures were executed, initialize the job file in the maintenance mode, and then load the saved job file. (4)If the alarm occurs again, save the CMOS.BIN in maintenance mode, and then contact your Yaskawa representative about occurrence status (operating procedure).
		12	An attempt was made to access the undefined position data.	Software operation error occurred	(1)Reset the alarm. (2)If the error occurs again, delete the job where the alarm occurred. (3)If the error occurs again after the previous measures were executed, initialize the job file in the maintenance mode, and then load the saved job file. (4)If the alarm occurs again, save the CMOS.BIN in maintenance mode, and then contact your Yaskawa representative about occurrence status (operating procedure).
		13	An attempt was made to access the position data for the undefined control group.	Software operation error occurred	(1)Reset the alarm. (2)If the error occurs again, delete the job where the alarm occurred. (3)If the error occurs again after the previous measures were executed, initialize the job file in the maintenance mode, and then load the saved job file. (4)If the alarm occurs again, save the CMOS.BIN in maintenance mode, and then contact your Yaskawa representative about occurrence status (operating procedure).
		17	An error occurred in exceptional control during the position data control process.	Software operation error occurred	(1)Reset the alarm. (2)If the error occurs again, delete the job where the alarm occurred. (3)If the error occurs again after the previous measures were executed, initialize the job file in the maintenance mode, and then load the saved job file. (4)If the alarm occurs again, save the CMOS.BIN in maintenance mode, and then contact your Yaskawa representative about occurrence status (operating procedure).

Alarm Number	Alarm Name	Sub Code	Meaning	Cause	Remedy
		20	Undefined position exists.	Software operation error occurred	(1)Reset the alarm. (2)If the error occurs again, delete the job where the alarm occurred. (3)If the error occurs again after the previous measures were executed, initialize the job file in the maintenance mode, and then load the saved job file. (4)If the alarm occurs again, save the CMOS.BIN in maintenance mode, and then contact your Yaskawa representative about occurrence status (operating procedure).
4206	SYSTEM ERROR (TRANSMISSION)		Sub Code 1 to 4: Signifies the internal software error during data transmission.	Software operation error occurred	(1)Turn the power OFF then back ON. (2)If the alarm occurs again, save the CMOS.BIN in maintenance mode, and then contact your Yaskawa representative about occurrence status (operating procedure).
4207	SYSTEM ERROR (MOTION)	1	An interrupt undefined in the main command from the system control section occurred.	Software operation error occurred	(1)Reset the alarm, and then try again. (2)If the alarm occurs again, save the CMOS.BIN in maintenance mode, and then contact your Yaskawa representative about occurrence status (operating procedure).
		2	An interrupt undefined in the sub command from the system control section occurred.	Software operation error occurred	(1)Reset the alarm, and then try again. (2)If the alarm occurs again, save the CMOS.BIN in maintenance mode, and then contact your Yaskawa representative about occurrence status (operating procedure).
		3	The interrupt command that was sent previously from the system control section is being processed.	Software operation error occurred	(1)Reset the alarm, and then try again. (2)If the alarm occurs again, save the CMOS.BIN in maintenance mode, and then contact your Yaskawa representative about occurrence status (operating procedure).
		4	An error was detected in the interrupt command data from the system control section.	Software operation error occurred	(1)Reset the alarm, and then try again. (2)If the alarm occurs again, save the CMOS.BIN in maintenance mode, and then contact your Yaskawa representative about occurrence status (operating procedure).
		5	An undefined command was detected in the sub segment task of MOTION section.	Software operation error occurred	(1)Reset the alarm, and then try again. (2)If the alarm occurs again, save the CMOS.BIN in maintenance mode, and then contact your Yaskawa representative about occurrence status (operating procedure).
		6	An undefined command was detected in the servo-related processing of MOTION section.	Software operation error occurred	(1)Reset the alarm, and then try again. (2)If the alarm occurs again, save the CMOS.BIN in maintenance mode, and then contact your Yaskawa representative about occurrence status (operating procedure).
		7	An undefined command was detected in the offline processing task of MOTION section.	Software operation error occurred	(1)Reset the alarm, and then try again. (2)If the alarm occurs again, save the CMOS.BIN in maintenance mode, and then contact your Yaskawa representative about occurrence status (operating procedure).

Alarm Number	Alarm Name	Sub Code	Meaning	Cause	Remedy
		8	An undefined command was detected in the utility task of MOTION section.	Software operation error occurred	(1)Reset the alarm, and then try again. (2)If the alarm occurs again, save the CMOS.BIN in maintenance mode, and then contact your Yaskawa representative about occurrence status (operating procedure).
		10	Task Token is not generated.	Software operation error occurred	(1)Reset the alarm, and then try again. (2)If the alarm occurs again, save the CMOS.BIN in maintenance mode, and then contact your Yaskawa representative about occurrence status (operating procedure).
		11	Mail-box Token is not generated.	Software operation error occurred	(1)Reset the alarm, and then try again. (2)If the alarm occurs again, save the CMOS.BIN in maintenance mode, and then contact your Yaskawa representative about occurrence status (operating procedure).
		12	Semaphore Token is not generated.	Software operation error occurred	(1)Reset the alarm, and then try again. (2)If the alarm occurs again, save the CMOS.BIN in maintenance mode, and then contact your Yaskawa representative about occurrence status (operating procedure).
		14	RMS receiving data error	Software operation error occurred	(1)Reset the alarm, and then try again. (2)If the alarm occurs again, save the CMOS.BIN in maintenance mode, and then contact your Yaskawa representative about occurrence status (operating procedure).
		15	RMS sending data error	Software operation error occurred	(1)Reset the alarm, and then try again. (2)If the alarm occurs again, save the CMOS.BIN in maintenance mode, and then contact your Yaskawa representative about occurrence status (operating procedure).
		16	RMS receiving unit error	Software operation error occurred	(1)Reset the alarm, and then try again. (2)If the alarm occurs again, save the CMOS.BIN in maintenance mode, and then contact your Yaskawa representative about occurrence status (operating procedure).
		18	Task generation error	Software operation error occurred	(1)Reset the alarm, and then try again. (2)If the alarm occurs again, save the CMOS.BIN in maintenance mode, and then contact your Yaskawa representative about occurrence status (operating procedure).
		19	Mail-box generation error	Software operation error occurred	(1)Reset the alarm, and then try again. (2)If the alarm occurs again, save the CMOS.BIN in maintenance mode, and then contact your Yaskawa representative about occurrence status (operating procedure).

Alarm Number	Alarm Name	Sub Code	Meaning	Cause	Remedy
		20	Semaphore generation error	Software operation error occurred	(1)Reset the alarm, and then try again. (2)If the alarm occurs again, save the CMOS.BIN in maintenance mode, and then contact your Yaskawa representative about occurrence status (operating procedure).
		22	TCB area overflow	Software operation error occurred	(1)Reset the alarm, and then try again. (2)If the alarm occurs again, save the CMOS.BIN in maintenance mode, and then contact your Yaskawa representative about occurrence status (operating procedure).
		23	Stack area overflow	Software operation error occurred	(1)Reset the alarm, and then try again. (2)If the alarm occurs again, save the CMOS.BIN in maintenance mode, and then contact your Yaskawa representative about occurrence status (operating procedure).
		24	Mail-box area overflow	Software operation error occurred	(1)Reset the alarm, and then try again. (2)If the alarm occurs again, save the CMOS.BIN in maintenance mode, and then contact your Yaskawa representative about occurrence status (operating procedure).
		25	Semaphore area overflow	Software operation error occurred	(1)Reset the alarm, and then try again. (2)If the alarm occurs again, save the CMOS.BIN in maintenance mode, and then contact your Yaskawa representative about occurrence status (operating procedure).
		30	Interrupt main command error	Software operation error occurred	(1)Reset the alarm, and then try again. (2)If the alarm occurs again, save the CMOS.BIN in maintenance mode, and then contact your Yaskawa representative about occurrence status (operating procedure).
		33	Incorrect control group designation	Software operation error occurred	(1)Reset the alarm, and then try again. (2)If the alarm occurs again, save the CMOS.BIN in maintenance mode, and then contact your Yaskawa representative about occurrence status (operating procedure).
		34	Offline bank semaphore reception error	Software operation error occurred	(1)Reset the alarm, and then try again. (2)If the alarm occurs again, save the CMOS.BIN in maintenance mode, and then contact your Yaskawa representative about occurrence status (operating procedure).
		35	m_gen_area semaphore reception error	Software operation error occurred	(1)Reset the alarm, and then try again. (2)If the alarm occurs again, save the CMOS.BIN in maintenance mode, and then contact your Yaskawa representative about occurrence status (operating procedure).

Alarm Number	Alarm Name	Sub Code	Meaning	Cause	Remedy
		36	Offline HA processing timeout	Software operation error occurred	(1)Reset the alarm, and then try again. (2)If the alarm occurs again, save the CMOS.BIN in maintenance mode, and then contact your Yaskawa representative about occurrence status (operating procedure).
		37	DM_BANK flag error (DM_BANK conversion processing)	Software operation error occurred	(1)Reset the alarm, and then try again. (2)If the alarm occurs again, save the CMOS.BIN in maintenance mode, and then contact your Yaskawa representative about occurrence status (operating procedure).
		38	S -> M offline processing command type error	Software operation error occurred	(1)Reset the alarm, and then try again. (2)If the alarm occurs again, save the CMOS.BIN in maintenance mode, and then contact your Yaskawa representative about occurrence status (operating procedure).
		39	Function specification error in the data transmission to the sensor board	Software operation error occurred	(1)Reset the alarm, and then try again. (2)If the alarm occurs again, save the CMOS.BIN in maintenance mode, and then contact your Yaskawa representative about occurrence status (operating procedure).
		40	Error in designation of application in the request of general-purpose data preset for each application.	Software operation error occurred	(1)Reset the alarm, and then try again. (2)If the alarm occurs again, save the CMOS.BIN in maintenance mode, and then contact your Yaskawa representative about occurrence status (operating procedure).
		45	Mail-box of sequence task is not ready.	Software operation error occurred	(1)Reset the alarm, and then try again. (2)If the alarm occurs again, save the CMOS.BIN in maintenance mode, and then contact your Yaskawa representative about occurrence status (operating procedure).
		46	Control-group usage undefined	Software operation error occurred	(1)Reset the alarm, and then try again. (2)If the alarm occurs again, save the CMOS.BIN in maintenance mode, and then contact your Yaskawa representative about occurrence status (operating procedure).
		47	Segment task polling command error	Software operation error occurred	(1)Reset the alarm, and then try again. (2)If the alarm occurs again, save the CMOS.BIN in maintenance mode, and then contact your Yaskawa representative about occurrence status (operating procedure).
		48	Physical axis number error	Software operation error occurred	(1)Reset the alarm, and then try again. (2)If the alarm occurs again, save the CMOS.BIN in maintenance mode, and then contact your Yaskawa representative about occurrence status (operating procedure).

Alarm Number	Alarm Name	Sub Code	Meaning	Cause	Remedy
		49	The control group impossible to release the brake	Software operation error occurred	(1)Reset the alarm, and then try again. (2)If the alarm occurs again, save the CMOS.BIN in maintenance mode, and then contact your Yaskawa representative about occurrence status (operating procedure).
		50	Sub-segment request FULL	Software operation error occurred	(1)Reset the alarm, and then try again. (2)If the alarm occurs again, save the CMOS.BIN in maintenance mode, and then contact your Yaskawa representative about occurrence status (operating procedure).
		51	Sub-segment process timeout	Software operation error occurred	(1)Reset the alarm, and then try again. (2)If the alarm occurs again, save the CMOS.BIN in maintenance mode, and then contact your Yaskawa representative about occurrence status (operating procedure).
		52	Data latch request FULL	Software operation error occurred	(1)Reset the alarm, and then try again. (2)If the alarm occurs again, save the CMOS.BIN in maintenance mode, and then contact your Yaskawa representative about occurrence status (operating procedure).
		53	Data latch process timeout	Software operation error occurred	(1)Reset the alarm, and then try again. (2)If the alarm occurs again, save the CMOS.BIN in maintenance mode, and then contact your Yaskawa representative about occurrence status (operating procedure).
		54	AXIS command request FULL	Software operation error occurred	(1)Reset the alarm, and then try again. (2)If the alarm occurs again, save the CMOS.BIN in maintenance mode, and then contact your Yaskawa representative about occurrence status (operating procedure).
		55	AXIS command process timeout	Software operation error occurred	(1)Reset the alarm, and then try again. (2)If the alarm occurs again, save the CMOS.BIN in maintenance mode, and then contact your Yaskawa representative about occurrence status (operating procedure).
		56	Positioning monitor request FULL	Software operation error occurred	(1)Reset the alarm, and then try again. (2)If the alarm occurs again, save the CMOS.BIN in maintenance mode, and then contact your Yaskawa representative about occurrence status (operating procedure).
		57	Positioning monitor process timeout	Software operation error occurred	(1)Reset the alarm, and then try again. (2)If the alarm occurs again, save the CMOS.BIN in maintenance mode, and then contact your Yaskawa representative about occurrence status (operating procedure).

Alarm Number	Alarm Name	Sub Code	Meaning	Cause	Remedy
			Failed AXIS servo OFF command request during category1 emergency stop	Software operation error occurred	(1)Reset the alarm, and then try again. (2)If the alarm occurs again, save the CMOS.BIN in maintenance mode, and then contact your Yaskawa representative about occurrence status (operating procedure).
		59	AXIS servo OFF command execution system not set during category1 emergency stop	Software operation error occurred	(1)Reset the alarm, and then try again. (2)If the alarm occurs again, save the CMOS.BIN in maintenance mode, and then contact your Yaskawa representative about occurrence status (operating procedure).
		61	Conversion primary expression for Power Source command <-> EW command not prepared	Software operation error occurred	(1)Reset the alarm, and then try again. (2)If the alarm occurs again, save the CMOS.BIN in maintenance mode, and then contact your Yaskawa representative about occurrence status (operating procedure).
		62	Duplicated request error during master control-group tracking	Software operation error occurred	(1)Reset the alarm, and then try again. (2)If the alarm occurs again, save the CMOS.BIN in maintenance mode, and then contact your Yaskawa representative about occurrence status (operating procedure).
		63	GVM shared resource semaphore error	Software operation error occurred	(1)Reset the alarm, and then try again. (2)If the alarm occurs again, save the CMOS.BIN in maintenance mode, and then contact your Yaskawa representative about occurrence status (operating procedure).
		64	Job queue DEQUE error	Software operation error occurred	(1)Reset the alarm, and then try again. (2)If the alarm occurs again, save the CMOS.BIN in maintenance mode, and then contact your Yaskawa representative about occurrence status (operating procedure).
		66	Execution system decision table not set	Software operation error occurred	(1)Reset the alarm, and then try again. (2)If the alarm occurs again, save the CMOS.BIN in maintenance mode, and then contact your Yaskawa representative about occurrence status (operating procedure).
		67	Unknown mode data (Without TEACH/PLAY mode data)	Software operation error occurred	(1)Reset the alarm, and then try again. (2)If the alarm occurs again, save the CMOS.BIN in maintenance mode, and then contact your Yaskawa representative about occurrence status (operating procedure).
		68	Shift-value output timeout of the general-purpose sensor	Software operation error occurred	(1)Reset the alarm, and then try again. (2)If the alarm occurs again, save the CMOS.BIN in maintenance mode, and then contact your Yaskawa representative about occurrence status (operating procedure).

Alarm Number	Alarm Name	Sub Code	Meaning	Cause	Remedy
		69	Interrupt main status set	Software operation error occurred	(1)Reset the alarm, and then try again. (2)If the alarm occurs again, save the CMOS.BIN in maintenance mode, and then contact your Yaskawa representative about occurrence status (operating procedure).
		71	System number error at the master side in twin synchronous system	Software operation error occurred	(1)Reset the alarm, and then try again. (2)If the alarm occurs again, save the CMOS.BIN in maintenance mode, and then contact your Yaskawa representative about occurrence status (operating procedure).
		72	No data link added to the command	Software operation error occurred	(1)Reset the alarm, and then try again. (2)If the alarm occurs again, save the CMOS.BIN in maintenance mode, and then contact your Yaskawa representative about occurrence status (operating procedure).
		73	Setting status error of the user coordinates file	Software operation error occurred	(1)Reset the alarm, and then try again. (2)If the alarm occurs again, save the CMOS.BIN in maintenance mode, and then contact your Yaskawa representative about occurrence status (operating procedure).
		75	Previous path data reference error	Software operation error occurred	(1)Reset the alarm, and then try again. (2)If the alarm occurs again, save the CMOS.BIN in maintenance mode, and then contact your Yaskawa representative about occurrence status (operating procedure).
		79	Inner track zone status error	Software operation error occurred	(1)Reset the alarm, and then try again. (2)If the alarm occurs again, save the CMOS.BIN in maintenance mode, and then contact your Yaskawa representative about occurrence status (operating procedure).
		80	Instruction queue and instruction system data area overflow	Software operation error occurred	(1)Reset the alarm, and then try again. (2)If the alarm occurs again, save the CMOS.BIN in maintenance mode, and then contact your Yaskawa representative about occurrence status (operating procedure).
		81	Offline answer bank flag error	Software operation error occurred	(1)Reset the alarm, and then try again. (2)If the alarm occurs again, save the CMOS.BIN in maintenance mode, and then contact your Yaskawa representative about occurrence status (operating procedure).
		82	Path and trace queue ENQUE BANK error	Software operation error occurred	(1)Reset the alarm, and then try again. (2)If the alarm occurs again, save the CMOS.BIN in maintenance mode, and then contact your Yaskawa representative about occurrence status (operating procedure).

Alarm Number	Alarm Name	Sub Code	Meaning	Cause	Remedy
		83	Pending and block end request FULL	Software operation error occurred	(1)Reset the alarm, and then try again. (2)If the alarm occurs again, save the CMOS.BIN in maintenance mode, and then contact your Yaskawa representative about occurrence status (operating procedure).
		84	Base axis file type error	Software operation error occurred	(1)Reset the alarm, and then try again. (2)If the alarm occurs again, save the CMOS.BIN in maintenance mode, and then contact your Yaskawa representative about occurrence status (operating procedure).
		85	Output buffer SYSCON for automatic test data in use	Software operation error occurred	(1)Reset the alarm, and then try again. (2)If the alarm occurs again, save the CMOS.BIN in maintenance mode, and then contact your Yaskawa representative about occurrence status (operating procedure).
		86	Conversion completion status for AXIS section feedback latch data not established	Software operation error occurred	(1)Reset the alarm, and then try again. (2)If the alarm occurs again, save the CMOS.BIN in maintenance mode, and then contact your Yaskawa representative about occurrence status (operating procedure).
		88	File C1 through C3 for calibration between manipulators not set	Software operation error occurred	(1)Reset the alarm, and then try again. (2)If the alarm occurs again, save the CMOS.BIN in maintenance mode, and then contact your Yaskawa representative about occurrence status (operating procedure).
		89	File C1 through C3 for conveyor calibration not set	Software operation error occurred	(1)Reset the alarm, and then try again. (2)If the alarm occurs again, save the CMOS.BIN in maintenance mode, and then contact your Yaskawa representative about occurrence status (operating procedure).
		90	HA function error (conv_pos_data())	Setting error	(1)Check the following settings. -Correct the job so that the target position data is within the motion range. (2)If the alarm occurs again, save the CMOS.BIN in maintenance mode, and then contact your Yaskawa representative about occurrence status (operating procedure).
		91	HA function error (conv_shift_data())	Setting error	(1)Check the following settings. -Correct the job so that the target position data is within the motion range. (2)If the alarm occurs again, save the CMOS.BIN in maintenance mode, and then contact your Yaskawa representative about occurrence status (operating procedure).
		94	HA function error (conv_pulse_to_angle())	Software operation error occurred	(1)Reset the alarm, and then try again. (2)If the alarm occurs again, save the CMOS.BIN in maintenance mode, and then contact your Yaskawa representative about occurrence status (operating procedure).

Alarm Number	Alarm Name	Sub Code	Meaning	Cause	Remedy
		100	Control-group axis configuration information parameter error	Software operation error occurred	(1)Reset the alarm, and then try again. (2)If the alarm occurs again, save the CMOS.BIN in maintenance mode, and then contact your Yaskawa representative about occurrence status (operating procedure).
		101	Error in the parameter for the table for physical axes	Software operation error occurred	(1)Reset the alarm, and then try again. (2)If the alarm occurs again, save the CMOS.BIN in maintenance mode, and then contact your Yaskawa representative about occurrence status (operating procedure).
		102	Error in the parameter for the table for physical TU	Software operation error occurred	(1)Reset the alarm, and then try again. (2)If the alarm occurs again, save the CMOS.BIN in maintenance mode, and then contact your Yaskawa representative about occurrence status (operating procedure).
		103	Excessive number of control group axes in use	Software operation error occurred	(1)Reset the alarm, and then try again. (2)If the alarm occurs again, save the CMOS.BIN in maintenance mode, and then contact your Yaskawa representative about occurrence status (operating procedure).
		104	JOG and PLAY maximum speed setting parameter error	Software operation error occurred	(1)Reset the alarm, and then try again. (2)If the alarm occurs again, save the CMOS.BIN in maintenance mode, and then contact your Yaskawa representative about occurrence status (operating procedure).
		121	Job argument stack overflow	Software operation error occurred	(1)Reset the alarm, and then try again. (2)If the alarm occurs again, save the CMOS.BIN in maintenance mode, and then contact your Yaskawa representative about occurrence status (operating procedure).
		122	Job argument stack underflow	Software operation error occurred	(1)Reset the alarm, and then try again. (2)If the alarm occurs again, save the CMOS.BIN in maintenance mode, and then contact your Yaskawa representative about occurrence status (operating procedure).
		123	Designation error of the fetched feedback pulse area at preparation of current value	Software operation error occurred	(1)Reset the alarm, and then try again. (2)If the alarm occurs again, save the CMOS.BIN in maintenance mode, and then contact your Yaskawa representative about occurrence status (operating procedure).
		128	Timeout for waiting permission to modify the number of averaging times	Software operation error occurred	(1)Reset the alarm, and then try again. (2)If the alarm occurs again, save the CMOS.BIN in maintenance mode, and then contact your Yaskawa representative about occurrence status (operating procedure).

Alarm Number	Alarm Name	Sub Code	Meaning	Cause	Remedy
		129	Object undefined for CLEAR instruction	Software operation error occurred	(1)Reset the alarm, and then try again. (2)If the alarm occurs again, save the CMOS.BIN in maintenance mode, and then contact your Yaskawa representative about occurrence status (operating procedure).
		130	No space in RT_BANK setting area for correction-amount data	Software operation error occurred	(1)Reset the alarm, and then try again. (2)If the alarm occurs again, save the CMOS.BIN in maintenance mode, and then contact your Yaskawa representative about occurrence status (operating procedure).
		131	Queue operation error for variable write-in history at prereading (at ENQUE)	Software operation error occurred	(1)Reset the alarm, and then try again. (2)If the alarm occurs again, save the CMOS.BIN in maintenance mode, and then contact your Yaskawa representative about occurrence status (operating procedure).
		132	Queue operation error for variable write-in history at prereading (at DEQUE)	Software operation error occurred	(1)Reset the alarm, and then try again. (2)If the alarm occurs again, save the CMOS.BIN in maintenance mode, and then contact your Yaskawa representative about occurrence status (operating procedure).
		133	Queue operation error for variable write-in history at prereading (undefined operation)	Software operation error occurred	(1)Reset the alarm, and then try again. (2)If the alarm occurs again, save the CMOS.BIN in maintenance mode, and then contact your Yaskawa representative about occurrence status (operating procedure).
		134	Queue operation error for variable write-in history at prereading (data length too long)	Software operation error occurred	(1)Reset the alarm, and then try again. (2)If the alarm occurs again, save the CMOS.BIN in maintenance mode, and then contact your Yaskawa representative about occurrence status (operating procedure).
		135	Queue operation error for score-board setting history (at ENQUE)	Software operation error occurred	(1)Reset the alarm, and then try again. (2)If the alarm occurs again, save the CMOS.BIN in maintenance mode, and then contact your Yaskawa representative about occurrence status (operating procedure).
		136	Queue operation error for score-board setting history (at DEQUE)	Software operation error occurred	(1)Reset the alarm, and then try again. (2)If the alarm occurs again, save the CMOS.BIN in maintenance mode, and then contact your Yaskawa representative about occurrence status (operating procedure).
		137	Queue operation error for score-board setting history (undefined operation)	Software operation error occurred	(1)Reset the alarm, and then try again. (2)If the alarm occurs again, save the CMOS.BIN in maintenance mode, and then contact your Yaskawa representative about occurrence status (operating procedure).

Alarm Number	Alarm Name	Sub Code	Meaning	Cause	Remedy
		138	Queue operation error for score-board setting history (data length too long)	Software operation error occurred	(1)Reset the alarm, and then try again. (2)If the alarm occurs again, save the CMOS.BIN in maintenance mode, and then contact your Yaskawa representative about occurrence status (operating procedure).
		139	Queue operation error for instruction execution (at ENQUE)	Software operation error occurred	(1)Reset the alarm, and then try again. (2)If the alarm occurs again, save the CMOS.BIN in maintenance mode, and then contact your Yaskawa representative about occurrence status (operating procedure).
		140	Queue operation error for instruction execution (at DEQUE)	Software operation error occurred	(1)Reset the alarm, and then try again. (2)If the alarm occurs again, save the CMOS.BIN in maintenance mode, and then contact your Yaskawa representative about occurrence status (operating procedure).
		141	Queue operation error for instruction execution (undefined operation)	Software operation error occurred	(1)Reset the alarm, and then try again. (2)If the alarm occurs again, save the CMOS.BIN in maintenance mode, and then contact your Yaskawa representative about occurrence status (operating procedure).
		142	Queue operation error for instruction execution (data length too long)	Software operation error occurred	(1)Reset the alarm, and then try again. (2)If the alarm occurs again, save the CMOS.BIN in maintenance mode, and then contact your Yaskawa representative about occurrence status (operating procedure).
		143	Queue operation error for WORK ID conveyor (at ENQUE)	Software operation error occurred	(1)Reset the alarm, and then try again. (2)If the alarm occurs again, save the CMOS.BIN in maintenance mode, and then contact your Yaskawa representative about occurrence status (operating procedure).
		144	Queue operation error for WORK ID conveyor (at DEQUE)	Software operation error occurred	(1)Reset the alarm, and then try again. (2)If the alarm occurs again, save the CMOS.BIN in maintenance mode, and then contact your Yaskawa representative about occurrence status (operating procedure).
		145	Queue operation error for WORK ID conveyor (undefined operation)	Software operation error occurred	(1)Reset the alarm, and then try again. (2)If the alarm occurs again, save the CMOS.BIN in maintenance mode, and then contact your Yaskawa representative about occurrence status (operating procedure).
		146	Queue operation error for WORK ID conveyor (data length too long)	Software operation error occurred	(1)Reset the alarm, and then try again. (2)If the alarm occurs again, save the CMOS.BIN in maintenance mode, and then contact your Yaskawa representative about occurrence status (operating procedure).

Alarm Number	Alarm Name	Sub Code	Meaning	Cause	Remedy
		147	Queue operation error for WORK IN/OUT checking conveyor (at ENQUE)	Software operation error occurred	(1)Reset the alarm, and then try again. (2)If the alarm occurs again, save the CMOS.BIN in maintenance mode, and then contact your Yaskawa representative about occurrence status (operating procedure).
		148	Queue operation error for WORK IN/OUT checking conveyor (at DEQUE)	Software operation error occurred	(1)Reset the alarm, and then try again. (2)If the alarm occurs again, save the CMOS.BIN in maintenance mode, and then contact your Yaskawa representative about occurrence status (operating procedure).
		149	Queue operation error for WORK IN/OUT checking conveyor (undefined operation)	Software operation error occurred	(1)Reset the alarm, and then try again. (2)If the alarm occurs again, save the CMOS.BIN in maintenance mode, and then contact your Yaskawa representative about occurrence status (operating procedure).
		150	Queue operation error for WORK IN/OUT checking conveyor (data length too long)	Software operation error occurred	(1)Reset the alarm, and then try again. (2)If the alarm occurs again, save the CMOS.BIN in maintenance mode, and then contact your Yaskawa representative about occurrence status (operating procedure).
		151	Queue operation error for waiting for semaphore for LOCK instruction (at ENQUE)	Software operation error occurred	(1)Reset the alarm, and then try again. (2)If the alarm occurs again, save the CMOS.BIN in maintenance mode, and then contact your Yaskawa representative about occurrence status (operating procedure).
		152	Queue operation error for waiting for semaphore for LOCK instruction (at DEQUE)	Software operation error occurred	(1)Reset the alarm, and then try again. (2)If the alarm occurs again, save the CMOS.BIN in maintenance mode, and then contact your Yaskawa representative about occurrence status (operating procedure).
		153	Queue operation error for waiting for semaphore for LOCK instruction (undefined operation)	Software operation error occurred	(1)Reset the alarm, and then try again. (2)If the alarm occurs again, save the CMOS.BIN in maintenance mode, and then contact your Yaskawa representative about occurrence status (operating procedure).
		154	Queue operation error for waiting for semaphore for LOCK instruction (data length too long)	Software operation error occurred	(1)Reset the alarm, and then try again. (2)If the alarm occurs again, save the CMOS.BIN in maintenance mode, and then contact your Yaskawa representative about occurrence status (operating procedure).
		221	Transfer data overflow in offline data bank	Software operation error occurred	(1)Reset the alarm, and then try again. (2)If the alarm occurs again, save the CMOS.BIN in maintenance mode, and then contact your Yaskawa representative about occurrence status (operating procedure).

Alarm Number	Alarm Name	Sub Code	Meaning	Cause	Remedy
		222	Impossible to execute system exclusive for system job	Software operation error occurred	(1)Reset the alarm, and then try again. (2)If the alarm occurs again, save the CMOS.BIN in maintenance mode, and then contact your Yaskawa representative about occurrence status (operating procedure).
		223	Event queue number range exceeded	Software operation error occurred	(1)Reset the alarm, and then try again. (2)If the alarm occurs again, save the CMOS.BIN in maintenance mode, and then contact your Yaskawa representative about occurrence status (operating procedure).
		225	The number of WORK ID data and the MAX. WORK FIND COUNT unmatched (MOTION ≠ CV)	Software operation error occurred	(1)Reset the alarm, and then try again. (2)If the alarm occurs again, save the CMOS.BIN in maintenance mode, and then contact your Yaskawa representative about occurrence status (operating procedure).
		226	The number of WORK IN/OUT data and the MAX. WORK FIND COUNT unmatched (MOTION ≠ CV)	Software operation error occurred	(1)Reset the alarm, and then try again. (2)If the alarm occurs again, save the CMOS.BIN in maintenance mode, and then contact your Yaskawa representative about occurrence status (operating procedure).
		227	Excessive number of scheduling for execution of instructions	Software operation error occurred	(1)Reset the alarm, and then try again. (2)If the alarm occurs again, save the CMOS.BIN in maintenance mode, and then contact your Yaskawa representative about occurrence status (operating procedure).
		228	Instruction execution scheduling impossible	Software operation error occurred	(1)Reset the alarm, and then try again. (2)If the alarm occurs again, save the CMOS.BIN in maintenance mode, and then contact your Yaskawa representative about occurrence status (operating procedure).
		229	Illegal 1st-line move instruction at execution of +SMOV instruction	Software operation error occurred	(1)Reset the alarm, and then try again. (2)If the alarm occurs again, save the CMOS.BIN in maintenance mode, and then contact your Yaskawa representative about occurrence status (operating procedure).
		230	Impossible to execute the slave circular interpolation and the master circular interpolation at the same time	Software operation error occurred	(1)Reset the alarm, and then try again. (2)If the alarm occurs again, save the CMOS.BIN in maintenance mode, and then contact your Yaskawa representative about occurrence status (operating procedure).
		232	Illegal index value for a +MOVx instruction	Software operation error occurred	(1)Reset the alarm, and then try again. (2)If the alarm occurs again, save the CMOS.BIN in maintenance mode, and then contact your Yaskawa representative about occurrence status (operating procedure).

Alarm Number	Alarm Name	Sub Code	Meaning	Cause	Remedy
		233	No xth-line move instruction exists where the master control group belongs.	Software operation error occurred	(1)Reset the alarm, and then try again. (2)If the alarm occurs again, save the CMOS.BIN in maintenance mode, and then contact your Yaskawa representative about occurrence status (operating procedure).
		234	Marking error for WORK ID conveyor queue (empty queue)	Software operation error occurred	(1)Reset the alarm, and then try again. (2)If the alarm occurs again, save the CMOS.BIN in maintenance mode, and then contact your Yaskawa representative about occurrence status (operating procedure).
		235	Marking error for WORK IN/OUT conveyor queue (empty queue)	Software operation error occurred	(1)Reset the alarm, and then try again. (2)If the alarm occurs again, save the CMOS.BIN in maintenance mode, and then contact your Yaskawa representative about occurrence status (operating procedure).
		236	Data error 1 at restarting after an emergency stop (actual status and the data status unmatched)	Software operation error occurred	(1)Reset the alarm, and then try again. (2)If the alarm occurs again, save the CMOS.BIN in maintenance mode, and then contact your Yaskawa representative about occurrence status (operating procedure).
		237	Data error 2 at restarting after an emergency stop (actual status and the data status unmatched)	Software operation error occurred	(1)Reset the alarm, and then try again. (2)If the alarm occurs again, save the CMOS.BIN in maintenance mode, and then contact your Yaskawa representative about occurrence status (operating procedure).
		238	Data error 3 at restarting after an emergency stop (actual status and the data status unmatched)	Software operation error occurred	(1)Reset the alarm, and then try again. (2)If the alarm occurs again, save the CMOS.BIN in maintenance mode, and then contact your Yaskawa representative about occurrence status (operating procedure).
		239	Timeout for receiving segment data output request	Software operation error occurred	(1)Reset the alarm, and then try again. (2)If the alarm occurs again, save the CMOS.BIN in maintenance mode, and then contact your Yaskawa representative about occurrence status (operating procedure).
		240	The number which designates the setting area of correction amount in RT_BANK exceeded the limit value.	Software operation error occurred	(1)Reset the alarm, and then try again. (2)If the alarm occurs again, save the CMOS.BIN in maintenance mode, and then contact your Yaskawa representative about occurrence status (operating procedure).
		241	Task error of the function calling source (cv_sync_intr ())	Software operation error occurred	(1)Reset the alarm, and then try again. (2)If the alarm occurs again, save the CMOS.BIN in maintenance mode, and then contact your Yaskawa representative about occurrence status (operating procedure).

Alarm Number	Alarm Name	Sub Code	Meaning	Cause	Remedy
		244	GETTOOLW manipulator designation error	Software operation error occurred	(1)Reset the alarm, and then try again. (2)If the alarm occurs again, save the CMOS.BIN in maintenance mode, and then contact your Yaskawa representative about occurrence status (operating procedure).
		245	Overflow of entry number for instruction execution	Software operation error occurred	(1)Reset the alarm, and then try again. (2)If the alarm occurs again, save the CMOS.BIN in maintenance mode, and then contact your Yaskawa representative about occurrence status (operating procedure).
		246	Data latch processing (function number overflow)	Software operation error occurred	(1)Reset the alarm, and then try again. (2)If the alarm occurs again, save the CMOS.BIN in maintenance mode, and then contact your Yaskawa representative about occurrence status (operating procedure).
		247	Data latch processing (real-time status number overflow)	Software operation error occurred	(1)Reset the alarm, and then try again. (2)If the alarm occurs again, save the CMOS.BIN in maintenance mode, and then contact your Yaskawa representative about occurrence status (operating procedure).
		248	Failed to set a timer unit. (No allocation space for timer unit setting)	Software operation error occurred	(1)Reset the alarm, and then try again. (2)If the alarm occurs again, save the CMOS.BIN in maintenance mode, and then contact your Yaskawa representative about occurrence status (operating procedure).
		250	GETS instruction internal error	Software operation error occurred	(1)Reset the alarm, and then try again. (2)If the alarm occurs again, save the CMOS.BIN in maintenance mode, and then contact your Yaskawa representative about occurrence status (operating procedure).
		251	SETFILE undefined file	Software operation error occurred	(1)Reset the alarm, and then try again. (2)If the alarm occurs again, save the CMOS.BIN in maintenance mode, and then contact your Yaskawa representative about occurrence status (operating procedure).
		252	GETFILE undefined file	Software operation error occurred	(1)Reset the alarm, and then try again. (2)If the alarm occurs again, save the CMOS.BIN in maintenance mode, and then contact your Yaskawa representative about occurrence status (operating procedure).
		253	The parameter was destroyed when a GETPRM instruction was executed.	Software operation error occurred	(1)Reset the alarm, and then try again. (2)If the alarm occurs again, save the CMOS.BIN in maintenance mode, and then contact your Yaskawa representative about occurrence status (operating procedure).

Alarm Number	Alarm Name	Sub Code	Meaning	Cause	Remedy
		254	Null pointer assignment detected	Software operation error occurred	(1)Reset the alarm, and then try again. (2)If the alarm occurs again, save the CMOS.BIN in maintenance mode, and then contact your Yaskawa representative about occurrence status (operating procedure).
		255	Function or other processing parameter error	Software operation error occurred	(1)Reset the alarm, and then try again. (2)If the alarm occurs again, save the CMOS.BIN in maintenance mode, and then contact your Yaskawa representative about occurrence status (operating procedure).
		260	Arithmetic answer is not set at prereading (ADV_HA_ANS.flag == OFF)	Software operation error occurred	(1)Reset the alarm, and then try again. (2)If the alarm occurs again, save the CMOS.BIN in maintenance mode, and then contact your Yaskawa representative about occurrence status (operating procedure).
		261	Heap area obtainment failure (A_BANK)	Software operation error occurred	(1)Reset the alarm, and then try again. (2)If the alarm occurs again, save the CMOS.BIN in maintenance mode, and then contact your Yaskawa representative about occurrence status (operating procedure).
		262	Heap area obtainment failure (C_BANK)	Software operation error occurred	(1)Reset the alarm, and then try again. (2)If the alarm occurs again, save the CMOS.BIN in maintenance mode, and then contact your Yaskawa representative about occurrence status (operating procedure).
		263	Heap area obtainment failure (Instruction queue)	Software operation error occurred	(1)Reset the alarm, and then try again. (2)If the alarm occurs again, save the CMOS.BIN in maintenance mode, and then contact your Yaskawa representative about occurrence status (operating procedure).
		264	Heap area obtainment failure (Path/trace queue)	Software operation error occurred	(1)Reset the alarm, and then try again. (2)If the alarm occurs again, save the CMOS.BIN in maintenance mode, and then contact your Yaskawa representative about occurrence status (operating procedure).
		278	MEASON TRQ instruction control axis specification error	Software operation error occurred	(1)Reset the alarm, and then try again. (2)If the alarm occurs again, save the CMOS.BIN in maintenance mode, and then contact your Yaskawa representative about occurrence status (operating procedure).
		279	Specified MSS system instance is not generated.	Software operation error occurred	(1)Reset the alarm, and then try again. (2)If the alarm occurs again, save the CMOS.BIN in maintenance mode, and then contact your Yaskawa representative about occurrence status (operating procedure).

Alarm Number	Alarm Name	Sub Code	Meaning	Cause	Remedy
		280	API ERROR (HDAS_get_alias_name())	Software operation error occurred	(1)Reset the alarm, and then try again. (2)If the alarm occurs again, save the CMOS.BIN in maintenance mode, and then contact your Yaskawa representative about occurrence status (operating procedure).
		500	SL undefined interrupt command (main command)	Software operation error occurred	(1)Reset the alarm, and then try again. (2)If the alarm occurs again, save the CMOS.BIN in maintenance mode, and then contact your Yaskawa representative about occurrence status (operating procedure).
		501	SL undefined interrupt command (sub command)	Software operation error occurred	(1)Reset the alarm, and then try again. (2)If the alarm occurs again, save the CMOS.BIN in maintenance mode, and then contact your Yaskawa representative about occurrence status (operating procedure).
		502	Previous SL interrupt command processing	Software operation error occurred	(1)Reset the alarm, and then try again. (2)If the alarm occurs again, save the CMOS.BIN in maintenance mode, and then contact your Yaskawa representative about occurrence status (operating procedure).
		503	SL interrupt command data error	Software operation error occurred	(1)Reset the alarm, and then try again. (2)If the alarm occurs again, save the CMOS.BIN in maintenance mode, and then contact your Yaskawa representative about occurrence status (operating procedure).
		999	Arithmetic section error (segment data all zero timeout)	Software operation error occurred	(1)Reset the alarm, and then try again. (2)If the alarm occurs again, save the CMOS.BIN in maintenance mode, and then contact your Yaskawa representative about occurrence status (operating procedure).
		1000	System clock (RTC) setting error	Software operation error occurred	(1)Reset the alarm, and then try again. (2)If the alarm occurs again, save the CMOS.BIN in maintenance mode, and then contact your Yaskawa representative about occurrence status (operating procedure).
		1001	System task priority arrangement error	Software operation error occurred	(1)Reset the alarm, and then try again. (2)If the alarm occurs again, save the CMOS.BIN in maintenance mode, and then contact your Yaskawa representative about occurrence status (operating procedure).
		1002	VxWorks primitive error (msgQCreate)	Software operation error occurred	(1)Reset the alarm, and then try again. (2)If the alarm occurs again, save the CMOS.BIN in maintenance mode, and then contact your Yaskawa representative about occurrence status (operating procedure).

Alarm Number	Alarm Name	Sub Code	Meaning	Cause	Remedy
		1003	VxWorks primitive error (msgQSend)	Software operation error occurred	(1)Reset the alarm, and then try again. (2)If the alarm occurs again, save the CMOS.BIN in maintenance mode, and then contact your Yaskawa representative about occurrence status (operating procedure).
		1005	VxWorks primitive error (semBCreate)	Software operation error occurred	(1)Reset the alarm, and then try again. (2)If the alarm occurs again, save the CMOS.BIN in maintenance mode, and then contact your Yaskawa representative about occurrence status (operating procedure).
		1007	VxWorks primitive error (semTake)	Software operation error occurred	(1)Reset the alarm, and then try again. (2)If the alarm occurs again, save the CMOS.BIN in maintenance mode, and then contact your Yaskawa representative about occurrence status (operating procedure).
		1100	Failed system job environment configuration	Software operation error occurred	(1)Reset the alarm, and then try again. (2)If the alarm occurs again, save the CMOS.BIN in maintenance mode, and then contact your Yaskawa representative about occurrence status (operating procedure).
		1101	MotoPlus environment setup error	Software operation error occurred	(1)Reset the alarm, and then try again. (2)If the alarm occurs again, save the CMOS.BIN in maintenance mode, and then contact your Yaskawa representative about occurrence status (operating procedure).
4208	SYSTEM ERROR (ARITH)	1	Prereading task is not completed.	Software operation error occurred	(1)Reset the alarm, and then try again. (2)If the alarm occurs again, save the CMOS.BIN in maintenance mode, and then contact your Yaskawa representative about occurrence status (operating procedure).
		6	No previous bank exists.	Software operation error occurred	(1)Reset the alarm, and then try again. (2)If the alarm occurs again, save the CMOS.BIN in maintenance mode, and then contact your Yaskawa representative about occurrence status (operating procedure).
		7	The answer bank flag is ON.	Software operation error occurred	(1)Reset the alarm, and then try again. (2)If the alarm occurs again, save the CMOS.BIN in maintenance mode, and then contact your Yaskawa representative about occurrence status (operating procedure).
		8	An error occurred in preparation of current position.	Software operation error occurred	(1)Reset the alarm, and then try again. (2)If the alarm occurs again, save the CMOS.BIN in maintenance mode, and then contact your Yaskawa representative about occurrence status (operating procedure).

Alarm Number	Alarm Name	Sub Code	Meaning	Cause	Remedy
		11	The previous bank's prereading conversion could not correctly be completed.	Software operation error occurred	(1)Reset the alarm, and then try again. (2)If the alarm occurs again, save the CMOS.BIN in maintenance mode, and then contact your Yaskawa representative about occurrence status (operating procedure).
		12	A manipulator designation error occurred at JOG operation using the external reference point.	Software operation error occurred	(1)Reset the alarm, and then try again. (2)If the alarm occurs again, save the CMOS.BIN in maintenance mode, and then contact your Yaskawa representative about occurrence status (operating procedure).
		13	Designation error of cubic interference coordinates	Software operation error occurred	(1)Reset the alarm, and then try again. (2)If the alarm occurs again, save the CMOS.BIN in maintenance mode, and then contact your Yaskawa representative about occurrence status (operating procedure).
		14	Path control position data error of prereading bank	Software operation error occurred	(1)Reset the alarm, and then try again. (2)If the alarm occurs again, save the CMOS.BIN in maintenance mode, and then contact your Yaskawa representative about occurrence status (operating procedure).
		16	Station/base axis motion command error	Software operation error occurred	(1)Reset the alarm, and then try again. (2)If the alarm occurs again, save the CMOS.BIN in maintenance mode, and then contact your Yaskawa representative about occurrence status (operating procedure).
		18	User coordinates number error	Software operation error occurred	(1)Reset the alarm, and then try again. (2)If the alarm occurs again, save the CMOS.BIN in maintenance mode, and then contact your Yaskawa representative about occurrence status (operating procedure).
		20	Prereading task not completed at master in twin synchronous system	Software operation error occurred	(1)Reset the alarm, and then try again. (2)If the alarm occurs again, save the CMOS.BIN in maintenance mode, and then contact your Yaskawa representative about occurrence status (operating procedure).
		23	Dynamic model arithmetic error	Software operation error occurred	(1)Reset the alarm, and then try again. (2)If the alarm occurs again, save the CMOS.BIN in maintenance mode, and then contact your Yaskawa representative about occurrence status (operating procedure).

Alarm Number	Alarm Name	Sub Code	Meaning	Cause	Remedy
		24	Speed limit control error (excessive moment of gravity)	Setting error	(1)Check the following settings. ·The allowable braking torque was exceeded only by the gravity moment. Set the gravity value of the tool within payload of the manipulator. ·Teach the manipulator orientation that does not become the overload for each axes. (2)If the alarm occurs again, save the CMOS.BIN in maintenance mode, and then contact your Yaskawa representative about occurrence status (operating procedure).
		25	Square root of a negative number	Software operation error occurred	(1)Reset the alarm, and then try again. (2)If the alarm occurs again, save the CMOS.BIN in maintenance mode, and then contact your Yaskawa representative about occurrence status (operating procedure).
		26	The system number is not set at master in twin synchronous system.	Software operation error occurred	(1)Reset the alarm, and then try again. (2)If the alarm occurs again, save the CMOS.BIN in maintenance mode, and then contact your Yaskawa representative about occurrence status (operating procedure).
		29	FORMCUT internal control error	Software operation error occurred	(1)Reset the alarm, and then try again. (2)If the alarm occurs again, save the CMOS.BIN in maintenance mode, and then contact your Yaskawa representative about occurrence status (operating procedure).
		35	No master-group is designated at preparation of master-tool user coordinates.	Software operation error occurred	(1)Reset the alarm, and then try again. (2)If the alarm occurs again, save the CMOS.BIN in maintenance mode, and then contact your Yaskawa representative about occurrence status (operating procedure).
		41	Pulse linked JOG function error	Software operation error occurred	(1)Reset the alarm, and then try again. (2)If the alarm occurs again, save the CMOS.BIN in maintenance mode, and then contact your Yaskawa representative about occurrence status (operating procedure).
		42	Special JOG operation error	Software operation error occurred	(1)Reset the alarm, and then try again. (2)If the alarm occurs again, save the CMOS.BIN in maintenance mode, and then contact your Yaskawa representative about occurrence status (operating procedure).
		57	Arithmetic error occurred when calculating the acceleration and deceleration time (Function acceleration and deceleration control)	Software operation error occurred	(1)Reset the alarm, and then try again. (2)If the alarm occurs again, save the CMOS.BIN in maintenance mode, and then contact your Yaskawa representative about occurrence status (operating procedure).

Alarm Number	Alarm Name	Sub Code	Meaning	Cause	Remedy
		59	Arithmetic error occurred when calculating PL control (Function acceleration and deceleration control)	Software operation error occurred	(1)Reset the alarm, and then try again. (2)If the alarm occurs again, save the CMOS.BIN in maintenance mode, and then contact your Yaskawa representative about occurrence status (operating procedure).
		60	Arithmetic error occurred when calculating Function acceleration and deceleration dry run.	Software operation error occurred	(1)Reset the alarm, and then try again. (2)If the alarm occurs again, save the CMOS.BIN in maintenance mode, and then contact your Yaskawa representative about occurrence status (operating procedure).
		61	Arithmetic error occurred when calculating current path of continuous motion stop operation	Software operation error occurred	(1)Reset the alarm, and then try again. (2)If the alarm occurs again, save the CMOS.BIN in maintenance mode, and then contact your Yaskawa representative about occurrence status (operating procedure).
		62	Arithmetic error occurred when calculating next path of continuous motion stop operation	Software operation error occurred	(1)Reset the alarm, and then try again. (2)If the alarm occurs again, save the CMOS.BIN in maintenance mode, and then contact your Yaskawa representative about occurrence status (operating procedure).
		63	Arithmetic error occurred when calculating acceleration time when continuous motion in the prereading processing	Software operation error occurred	(1)Reset the alarm, and then try again. (2)If the alarm occurs again, save the CMOS.BIN in maintenance mode, and then contact your Yaskawa representative about occurrence status (operating procedure).
		64	Arithmetic error occurred when calculating deceleration time when continuous motion in the prereading processing	Software operation error occurred	(1)Reset the alarm, and then try again. (2)If the alarm occurs again, save the CMOS.BIN in maintenance mode, and then contact your Yaskawa representative about occurrence status (operating procedure).
		65	Arithmetic error occurred when calculating acceleration and deceleration time when teaching.	Software operation error occurred	(1)Reset the alarm, and then try again. (2)If the alarm occurs again, save the CMOS.BIN in maintenance mode, and then contact your Yaskawa representative about occurrence status (operating procedure).
		66	Arithmetic error occurred when calculating acceleration and deceleration time for plucking in prereading processing 1	Software operation error occurred	(1)Reset the alarm, and then try again. (2)If the alarm occurs again, save the CMOS.BIN in maintenance mode, and then contact your Yaskawa representative about occurrence status (operating procedure).
		67	Arithmetic error occurred when calculating acceleration and deceleration time for plucking in prereading processing 2	Software operation error occurred	(1)Reset the alarm, and then try again. (2)If the alarm occurs again, save the CMOS.BIN in maintenance mode, and then contact your Yaskawa representative about occurrence status (operating procedure).

Alarm Number	Alarm Name	Sub Code	Meaning	Cause	Remedy
		68	Arithmetic error occurred when calculating acceleration and deceleration time for plucking in prereading processing 3	Software operation error occurred	(1)Reset the alarm, and then try again. (2)If the alarm occurs again, save the CMOS.BIN in maintenance mode, and then contact your Yaskawa representative about occurrence status (operating procedure).
		69	Arithmetic error occurred when calculating acceleration and deceleration time for plucking in prereading processing 4	Software operation error occurred	(1)Reset the alarm, and then try again. (2)If the alarm occurs again, save the CMOS.BIN in maintenance mode, and then contact your Yaskawa representative about occurrence status (operating procedure).
		70	Arithmetic error occurred when calculating acceleration and deceleration for PL control plucking in prereading processing 1	Software operation error occurred	(1)Reset the alarm, and then try again. (2)If the alarm occurs again, save the CMOS.BIN in maintenance mode, and then contact your Yaskawa representative about occurrence status (operating procedure).
		71	Arithmetic error occurred when calculating acceleration and deceleration for PL control plucking in prereading processing 2	Software operation error occurred	(1)Reset the alarm, and then try again. (2)If the alarm occurs again, save the CMOS.BIN in maintenance mode, and then contact your Yaskawa representative about occurrence status (operating procedure).
		72	Arithmetic error occurred when calculating acceleration and deceleration for plucking	Software operation error occurred	(1)Reset the alarm, and then try again. (2)If the alarm occurs again, save the CMOS.BIN in maintenance mode, and then contact your Yaskawa representative about occurrence status (operating procedure).
		73	Arithmetic error occurred when calculating acceleration and deceleration for PL control in prereading processing 1	Software operation error occurred	(1)Reset the alarm, and then try again. (2)If the alarm occurs again, save the CMOS.BIN in maintenance mode, and then contact your Yaskawa representative about occurrence status (operating procedure).
		74	Arithmetic error occurred when calculating acceleration and deceleration for PL control in prereading processing 2	Software operation error occurred	(1)Reset the alarm, and then try again. (2)If the alarm occurs again, save the CMOS.BIN in maintenance mode, and then contact your Yaskawa representative about occurrence status (operating procedure).
		75	Arithmetic error occurred when calculating acceleration and deceleration for PL control in prereading processing 3	Software operation error occurred	(1)Reset the alarm, and then try again. (2)If the alarm occurs again, save the CMOS.BIN in maintenance mode, and then contact your Yaskawa representative about occurrence status (operating procedure).

Alarm Number	Alarm Name	Sub Code	Meaning	Cause	Remedy
		76	Arithmetic error occurred when calculating acceleration and deceleration for PL control in prereading processing 4	Software operation error occurred	(1)Reset the alarm, and then try again. (2)If the alarm occurs again, save the CMOS.BIN in maintenance mode, and then contact your Yaskawa representative about occurrence status (operating procedure).
		77	Arithmetic error occurred when calculating acceleration and deceleration for PL control in prereading processing 5	Software operation error occurred	(1)Reset the alarm, and then try again. (2)If the alarm occurs again, save the CMOS.BIN in maintenance mode, and then contact your Yaskawa representative about occurrence status (operating procedure).
		85	Arithmetic error occurred when acceleration and deceleration for canceling PL control of station were recalculated.	Software operation error occurred	(1)Reset the alarm, and then try again. (2)If the alarm occurs again, save the CMOS.BIN in maintenance mode, and then contact your Yaskawa representative about occurrence status (operating procedure).
		86	PL during current → Arithmetic error occurred when calculating acceleration time for CONT	Software operation error occurred	(1)Reset the alarm, and then try again. (2)If the alarm occurs again, save the CMOS.BIN in maintenance mode, and then contact your Yaskawa representative about occurrence status (operating procedure).
		87	Arithmetic error occurred when calculating acceleration and deceleration for PL control in prereading processing	Software operation error occurred	(1)Reset the alarm, and then try again. (2)If the alarm occurs again, save the CMOS.BIN in maintenance mode, and then contact your Yaskawa representative about occurrence status (operating procedure).
		88	Arithmetic error occurred when acceleration and deceleration for moving to the different conveyer coordinate were calculated.	Software operation error occurred	(1)Reset the alarm, and then try again. (2)If the alarm occurs again, save the CMOS.BIN in maintenance mode, and then contact your Yaskawa representative about occurrence status (operating procedure).
		89	Operation command group which pre-reading is not completed detection error	Software operation error occurred	(1)Reset the alarm, and then try again. (2)If the alarm occurs again, save the CMOS.BIN in maintenance mode, and then contact your Yaskawa representative about occurrence status (operating procedure).
		65535	For HA debug use	Software operation error occurred	(1)Reset the alarm, and then try again. (2)If the alarm occurs again, save the CMOS.BIN in maintenance mode, and then contact your Yaskawa representative about occurrence status (operating procedure).
4209	OFFLINE SYSTEM ERROR (ARITH)	100	Data setting error in offline data bank	Software operation error occurred	(1)Reset the alarm, and then try again. (2)If the alarm occurs again, save the CMOS.BIN in maintenance mode, and then contact your Yaskawa representative about occurrence status (operating procedure).

Alarm Number	Alarm Name	Sub Code	Meaning	Cause	Remedy
		101	Data setting error in offline answer bank	Software operation error occurred	(1)Reset the alarm, and then try again. (2)If the alarm occurs again, save the CMOS.BIN in maintenance mode, and then contact your Yaskawa representative about occurrence status (operating procedure).
		102	OFF_USER_POS occupation control error	Software operation error occurred	(1)Reset the alarm, and then try again. (2)If the alarm occurs again, save the CMOS.BIN in maintenance mode, and then contact your Yaskawa representative about occurrence status (operating procedure).
		103	OFF_USER_POS valid control error	Software operation error occurred	(1)Reset the alarm, and then try again. (2)If the alarm occurs again, save the CMOS.BIN in maintenance mode, and then contact your Yaskawa representative about occurrence status (operating procedure).
		104	Mail-receiving error of offline task	Software operation error occurred	(1)Reset the alarm, and then try again. (2)If the alarm occurs again, save the CMOS.BIN in maintenance mode, and then contact your Yaskawa representative about occurrence status (operating procedure).
		105	Offline occupation control error	Software operation error occurred	(1)Reset the alarm, and then try again. (2)If the alarm occurs again, save the CMOS.BIN in maintenance mode, and then contact your Yaskawa representative about occurrence status (operating procedure).
		107	OFF_USER_ROT_POS occupation control error	Software operation error occurred	(1)Reset the alarm, and then try again. (2)If the alarm occurs again, save the CMOS.BIN in maintenance mode, and then contact your Yaskawa representative about occurrence status (operating procedure).
		108	OFF_USER_ROT_POS valid control error	Software operation error occurred	(1)Reset the alarm, and then try again. (2)If the alarm occurs again, save the CMOS.BIN in maintenance mode, and then contact your Yaskawa representative about occurrence status (operating procedure).
		109	OFF_CV_CALIB_POS occupation control error	Software operation error occurred	(1)Reset the alarm, and then try again. (2)If the alarm occurs again, save the CMOS.BIN in maintenance mode, and then contact your Yaskawa representative about occurrence status (operating procedure).
		110	OFF_CV_CALIB_POS valid control error	Software operation error occurred	(1)Reset the alarm, and then try again. (2)If the alarm occurs again, save the CMOS.BIN in maintenance mode, and then contact your Yaskawa representative about occurrence status (operating procedure).

Alarm Number	Alarm Name	Sub Code	Meaning	Cause	Remedy
		111	Incorrect teaching for offline conveyor tracking turntable function	Software operation error occurred	(1)Reset the alarm, and then try again. (2)If the alarm occurs again, save the CMOS.BIN in maintenance mode, and then contact your Yaskawa representative about occurrence status (operating procedure).
		112	No manipulator is designated for offline conveyor tracking turntable function.	Software operation error occurred	(1)Reset the alarm, and then try again. (2)If the alarm occurs again, save the CMOS.BIN in maintenance mode, and then contact your Yaskawa representative about occurrence status (operating procedure).
4210	SYSTEM ERROR (LOCAL VARIABLE)	-1	Local variable is not used.	Software operation error occurred	(1)Reset the alarm, and then try again. (2)If the alarm occurs again, save the CMOS.BIN in maintenance mode, and then contact your Yaskawa representative about occurrence status (operating procedure).
		-2	Memory area for local variable could not be obtained.	Software operation error occurred	(1)Reset the alarm, and then try again. (2)If the alarm occurs again, save the CMOS.BIN in maintenance mode, and then contact your Yaskawa representative about occurrence status (operating procedure).
		-3	No unused handle value exists when local variable area is created.	Software operation error occurred	(1)Reset the alarm, and then try again. (2)If the alarm occurs again, save the CMOS.BIN in maintenance mode, and then contact your Yaskawa representative about occurrence status (operating procedure).
		-4	An error occurred in exclusive control.	Software operation error occurred	(1)Reset the alarm, and then try again. (2)If the alarm occurs again, save the CMOS.BIN in maintenance mode, and then contact your Yaskawa representative about occurrence status (operating procedure).
		-5	Handle value is invalid for specified local variable.	Software operation error occurred	(1)Reset the alarm, and then try again. (2)If the alarm occurs again, save the CMOS.BIN in maintenance mode, and then contact your Yaskawa representative about occurrence status (operating procedure).
		-6	Handle value is incorrect for specified local variable.	Software operation error occurred	(1)Reset the alarm, and then try again. (2)If the alarm occurs again, save the CMOS.BIN in maintenance mode, and then contact your Yaskawa representative about occurrence status (operating procedure).
		-7	An error occurred when memory area for local variable was released.	Software operation error occurred	(1)Reset the alarm, and then try again. (2)If the alarm occurs again, save the CMOS.BIN in maintenance mode, and then contact your Yaskawa representative about occurrence status (operating procedure).

Alarm Number	Alarm Name	Sub Code	Meaning	Cause	Remedy
		-8	An error occurred when memory area for local variable was registered.	Software operation error occurred	(1)Reset the alarm, and then try again. (2)If the alarm occurs again, save the CMOS.BIN in maintenance mode, and then contact your Yaskawa representative about occurrence status (operating procedure).
		-9	Local variable control process is not initialized.	Software operation error occurred	(1)Reset the alarm, and then try again. (2)If the alarm occurs again, save the CMOS.BIN in maintenance mode, and then contact your Yaskawa representative about occurrence status (operating procedure).
		-10	Local variable area shared heap area.	Software operation error occurred	(1)Reset the alarm, and then try again. (2)If the alarm occurs again, save the CMOS.BIN in maintenance mode, and then contact your Yaskawa representative about occurrence status (operating procedure).
		-11	An error occurred in exclusive control.	Software operation error occurred	(1)Reset the alarm, and then try again. (2)If the alarm occurs again, save the CMOS.BIN in maintenance mode, and then contact your Yaskawa representative about occurrence status (operating procedure).
		-12	An error occurred in exclusive control when control of the local variable was processed.	Software operation error occurred	(1)Reset the alarm, and then try again. (2)If the alarm occurs again, save the CMOS.BIN in maintenance mode, and then contact your Yaskawa representative about occurrence status (operating procedure).
4220	SERVO POWER OFF FOR JOB		Sub Code: Control group	Setting error	(1)Check the following settings. ·Turn OFF the servo power supply, and then turn ON the servo power supply for the group axis to be operated.
4221	SERVO POWER OFF FOR JOB		Sub Code: Control group	Setting error	·Turn OFF the servo power supply, and then turn ON the servo power supply for the group axis to be operated.
4226	COMMUNICATION SERVICE ERROR	1	The communication channel could not be opened/closed at OPEN/CLOSE instruction execution.	Setting error	(1)Check the following settings. ·Setting of the RS (transmission) parameter
		100	The communication port is already opened.	Setting error	(1)Check the following settings. The serial port setting
		101	The communication port is not opened.	Setting error	(1)Check the following settings. The serial port setting
		102	No space was found in data sent buffer.	Setting error	(1)Check the following settings. The serial port setting
		103	The setting value for the event queue designation parameter is incorrect.	Setting error	(1)Check the following settings. ·RS157···Set to 1 to 4

Alarm Number	Alarm Name	Sub Code	Meaning	Cause	Remedy
		105	The type of output data is incorrect.	Setting error	(1)Check the following settings. The serial port setting
4228	WRONG DATA			Software operation error occurred	(1)Reset the alarm, and then execute following operation. ·Select a sub menu [WRONG DATA LOG] under main menu [SETUP]. ·Execute "RESTORE" by selecting "UTILITY" from the pull-down menu. *Occurrence date changes to restoration date after it is restored. ·Turn the power ON again and confirm the causes of the wrong data 1 and 2. Cause 1: Confirm the position of the file. Cause 2: Register the position of the file again. *As for the Cause 3, there is no confirming item after the power is turned ON. (2) If the restoration cannot be completed, execute the followings. ·Execute "RECONFIRM" by selecting "UTILITY" from the pull-down menu. (3)If the alarm occurs again, save the CMOS.BIN in maintenance mode, and then contact your Yaskawa representative about occurrence status (operating procedure).
				Data error	(1) If different axes configuration data is loaded, the system data becomes incorrect status, which causes this alarm. In this case, execute the following operations. ·Select a sub menu [WRONG DATA LOG] under main menu [SETUP]. ·Execute "RESTORE" by selecting "UTILITY" from the pull-down menu. ·Load the correct axes configuration. (2) If the restoration cannot be completed, execute the followings. ·Execute "RECONFIRM" by selecting "UTILITY" from the pull-down menu. (3)If the alarm occurs again, save the CMOS.BIN in maintenance mode, and then contact your Yaskawa representative about occurrence status (operating procedure).
4229	ETHERNET PROCESS ERROR	1	An error occurred in the acquisition process of the IP address during the IP address monitoring process of the Ethernet function.	Setting error	(1)Check the following settings. ·The DHCP server operation (If the DHCP is used) ·The network status (If the DHCP is used)
				Main CPU board failure	(1)Turn the power OFF then back ON. (2)If the alarm occurs again, replace controller.
		2	An error occurred in the acquisition process of subnet mask during the network service data creation process of the Ethernet function.	Setting error	(1)Check the following settings. ·The DHCP server operation (If the DHCP is used) ·The network status (If the DHCP is used)
				Main CPU board failure	(1)Turn the power OFF then back ON. (2)If the alarm occurs again, replace controller.

Alarm Number	Alarm Name	Sub Code	Meaning	Cause	Remedy
		3	An error occurred in the acquisition process of gateway during the network service data creation process of the Ethernet function.	Setting error	(1)Check the following settings. ·The DHCP server operation (If the DHCP is used) ·The network status (If the DHCP is used)
				Main CPU board failure	(1)Turn the power OFF then back ON. (2)If the alarm occurs again, replace controller.
		4	An error occurred in the conversion process of gateway address during the network service data creation process of the Ethernet function.	Setting error	(1)Check the following settings. ·The DHCP server operation (If the DHCP is used) ·The network status (If the DHCP is used)
				Main CPU board failure	(1)Turn the power OFF then back ON. (2)If the alarm occurs again, replace controller.
		6	An error occurred in the acquisition process of domain during the network service data creation process of the Ethernet function.	Setting error	(1)Check the following settings. ·The DHCP server operation (If the DHCP is used) ·The network status (If the DHCP is used)
				Main CPU board failure	(1)Turn the power OFF then back ON. (2)If the alarm occurs again, replace controller.
		8	An error occurred in the acquisition process of host name during the network service data creation process of the Ethernet function.	Setting error	(1)Check the following settings. ·The DHCP server operation (If the DHCP is used) ·The network status (If the DHCP is used)
				Main CPU board failure	(1)Turn the power OFF then back ON. (2)If the alarm occurs again, replace controller.
4300	VERIFY ERROR (SERVO PARAMETER)			Setting error	(1)Reset the alarm (2)If the alarm occurs again, check the parameter setting if there were any parameters which were modified before the alarm. (3)If the alarm occurs again or when it occurs other than above mentioned (2) case, contact your Yaskawa representative.
				Servo control board failure	(1)Reset the alarm (2)If the alarm occurs again, replace controller. Save the CMOS.BIN before replace controller to be safe.

Alarm Number	Alarm Name	Sub Code	Meaning	Cause	Remedy
4302	BRAKE CIRCUIT ERROR			Software operation error occurred	(1)Reset the alarm (2)If the alarm occurs again, save the CMOS.BIN in maintenance mode, and then contact your Yaskawa representative about occurrence status (operating procedure).
				Servo control board failure	(1)Reset the alarm (2)If the alarm occurs again, replace controller. Save the CMOS.BIN before replace controller to be safe.
4303	CONVERTER READY SIGNAL ERROR		Sub Code: Signifies the physical No. of converter in which the alarm occurred	Connection failure	(1)Reset the alarm (2)If the alarm occurs again, replace controller. Save the CMOS.BIN before replace controller to be safe.
				Module failure (converter)	(1)Reset the alarm (2)If the alarm occurs again, replace controller. Save the CMOS.BIN before replace controller to be safe.
				Servo control board failure	(1)Reset the alarm (2)If the alarm occurs again, replace controller. Save the CMOS.BIN before replace controller to be safe.
4304	CONVERTER INPUT POWER ERROR		Sub Code: Signifies the physical No. of converter in which the alarm occurred	Module failure (converter)	(1)Reset the alarm (2)If the alarm occurs again, replace controller. Save the CMOS.BIN before replace controller to be safe.
				Connection failure	(1)Reset the alarm (2)If the alarm occurs again, replace controller. Save the CMOS.BIN before replace controller to be safe.
4305	CONVERTER CIRCUIT CHARGE ERROR		Sub Code: Signifies the physical No. of converter in which the alarm occurred	Module failure (converter)	(1)Reset the alarm (2)If the alarm occurs again, replace controller. Save the CMOS.BIN before replace controller to be safe.
				Module failure (Regenerative resistor)	(1)Reset the alarm (2)If the alarm occurs again, replace controller. Save the CMOS.BIN before replace controller to be safe.
4307	SERVO ON DEFECTIVE SPEED		Sub Code: Signifies the axis in which the alarm occurred	Movement of axis when the SERVO ON process	Turn ON the servo power after 5 or more seconds from the alarm occurrence.
				Mechanical failure	Check that the manipulator is not moving when the servo turned ON.
				Servo control board failure	(1)Reset the alarm (2)If the alarm occurs again, replace controller. Save the CMOS.BIN before replace controller to be safe.

Alarm Number	Alarm Name	Sub Code	Meaning	Cause	Remedy
				Connection failure	(1)Reset the alarm (2)If the alarm occurs again, check the connection and inserting state of the following cables and connectors. {Robot axis} · Cable between encoders {External axis} · Cable between encoders (3)If the alarm occurs again, replace controller
				Module failure (motor)	(1)Reset the alarm (2)If the alarm occurs again, replace the motor.
4308	VOLTAGE DROP (CONVERTER)		Sub Code: Signifies the physical No. of converter in which the alarm occurred	Voltage failure	Check if the primary power supply voltage is dropping.
				Connection failure	(1)Reset the alarm (2)If the alarm occurs again, replace controller. Save the CMOS.BIN before replace controller to be safe.
				Module failure (converter)	(1)Reset the alarm (2)If the alarm occurs again, replace controller. Save the CMOS.BIN before replace controller to be safe.
				Servo control board failure	(1)Reset the alarm (2)If the alarm occurs again, replace controller. Save the CMOS.BIN before replace controller to be safe.
4309	DEFECTIVE ENCODER INTERNAL DATA		Sub Code: Signifies the axis in which the alarm occurred	Connection failure	(1)Reset the alarm (2)If the alarm occurs again, check the connection and inserting state of the following cables and connectors. {Robot axis} · Cable between encoders {External axis} · Cable between encoders (3)If the alarm occurs again, replace controller
				Module failure (encoder)	(1)Reset the alarm (2)If the alarm occurs again, replace the encoder.
4310	ENCODER OVERHEAT		Sub Code: Signifies the axis in which the alarm occurred	Overheated encoder	Turn OFF the power supply for about 10 minutes.
				High ambient temperature	Adjust the ambient temperature to 40°C or less.
				Module failure (encoder)	(1)Reset the alarm (2)If the alarm occurs again, replace the encoder.

Alarm Number	Alarm Name	Sub Code	Meaning	Cause	Remedy
				Servo control board failure	(1)Reset the alarm (2)If the alarm occurs again, replace controller. Save the CMOS.BIN before replace controller to be safe.
4311	ENCODER BACK-UP ERROR		Sub Code: Signifies the axis in which the alarm occurred	Module failure (encoder battery)	[AL-4314 occurred] Replace the battery of the axis in which the error occurred. [AL-1327 occurred] Replace the battery of the axis in which the alarm occurred. If the home position of the corresponding axis is displays as "****", register the home position.
				Connection failure	(1)Reset the alarm (2)If the alarm occurs again, check the connection and inserting state of the following cables and connectors. {Robot axis} ·Cable between encoders {External axis} ·Cable between encoders
				Module failure (encoder)	(1)Reset the alarm (2)If the alarm occurs again, replace the encoder.
				Servo control board failure	(1)Reset the alarm (2)If the alarm occurs again, replace controller. Save the CMOS.BIN before replace controller to be safe.
4312	ENCODER BATTERY ERROR			Module failure (encoder battery)	Replace the battery.
				Connection failure	(1)Reset the alarm (2)If the alarm occurs again, check the connection and inserting state of the following cables and connectors. ·Manipulator cable
4315	COLLISION DETECT		Sub Code: Signifies the axis in which the alarm occurred	Setting error	Check the following settings. ·The tool information ·The selection tap of the transfer ·The collision detection level ·JOB ·Work ·The speed of JOB ·The acceleration/deceleration speed of ACC and DEC ·Length of the power cables ·Diameter of the power cable

Alarm Number	Alarm Name	Sub Code	Meaning	Cause	Remedy
				Interference error	Remove the following interferences. ·The interferences to the jigs of Robot. ·The interferences to the jigs of workpieces. ·If there is no interference between robot and workpieces, set the shock detection level to more than maximum external value. Up to 500% of the level is possible.
				Connection failure	(1)Reset the alarm. (2)If the alarm occurs again, check the connection and inserting state of the following cables and connectors. ·The motor power line ·The encoder line
				Connection failure	(1) If the alarm occurs again, check the wiring of phase-U, -V, and -W isn't disconnected. (2) If disconnected, replace the motor power wire.
				Connection failure	(1) Check that the motor brake wire is not disconnected. (2) If disconnected, replace the motor brake wire.
				Servo control board failure	(1)Reset the alarm (2)If the alarm occurs again, replace controller. Save the CMOS.BIN before replace controller to be safe.
				Module failure (amplifier)	(1)Reset the alarm (2)If the alarm occurs again, replace controller. Save the CMOS.BIN before replace controller to be safe.
				Module failure (motor)	(1)Reset the alarm (2)If the alarm occurs again, replace the motor.
				Maintenance failure	Measure the density of grease iron powder in the speed reducer and do the maintenance.
				Defective speed reducer	Replace the speed reducer or the grease of it.
4318	SERIAL ENCODER CORRECTION LIMIT		Sub Code: Signifies the axis in which the alarm occurred	Connection failure	(1)Reset the alarm (2)If the alarm occurs again, check the connection and inserting state of the following cables and connectors. {Robot axis} ·Cable between encoders {External axis} ·Cable between encoders
				Module failure (encoder)	(1)Reset the alarm. (2)If the alarm occurs again, replace the encoder.

Alarm Number	Alarm Name	Sub Code	Meaning	Cause	Remedy
				Servo control board failure	(1)Reset the alarm (2)If the alarm occurs again, replace controller. Save the CMOS.BIN before replace controller to be safe.
4320	OVERLOAD (CONTINUE)		Sub Code: Signifies the axis in which the alarm occurred	Setting error	Check the following settings. ·The tools or the mass of the workpieces
				Interference with peripheral devices	Remove interference with the workpiece and peripheral device.
				Setting error	Review the JOB to check if the load factor doesn't exceed 100%.
				Servo control board failure	(1)Reset the alarm (2)If the alarm occurs again, replace controller. Save the CMOS.BIN before replace controller to be safe.
				Connection failure	(1)Reset the alarm. (2)If the alarm occurs again, replace the following cables. ·The wire harness in the robot.
				Module failure (motor)	(1)Reset the alarm. (2)If the alarm occurs again, replace the motor.
				Module failure (converter)	(1)Reset the alarm (2)If the alarm occurs again, replace controller. Save the CMOS.BIN before replace controller to be safe.
4321	OVERLOAD (MOMENT)		Sub Code: Signifies the axis in which the alarm occurred	Setting error	Check the following settings. ·The tools or the mass of the workpieces
				Interference error	Remove interference with the workpiece and peripheral device.
				Setting error	Correct the job whether load late does not exceed 100%.
				Servo control board failure	(1)Check that 24V is generated to the brake bolt of the following terminals. ·Motor brake terminal (2)If the alarm occurs again, replace controller. Save the CMOS.BIN before replace controller to be safe.
				Connection failure	(1)Reset the alarm. (2)If the alarm occurs again, replace the following cables. ·The wire harness in the robot.
				Module failure (motor)	(1)Reset the alarm. (2)If the alarm occurs again, replace the motor.
				Module failure (converter)	(1)Reset the alarm (2)If the alarm occurs again, replace controller. Save the CMOS.BIN before replace controller to be safe.

Alarm Number	Alarm Name	Sub Code	Meaning	Cause	Remedy
4322	AMPLIFIER OVERLOAD (CONTINUE)		Sub Code: Signifies the axis in which the alarm occurred	Setting error	Check the following settings. ·The tools or the mass of the workpieces
				Interference error	Remove interference with the workpiece and peripheral device.
				Setting error	Correct the job whether load late does not exceed 100%.
				Servo control board failure	(1)Check that 24V is generated to the brake bolt of the following terminals. ·Motor brake terminal (2)If the alarm occurs again, replace controller. Save the CMOS.BIN before replace controller to be safe.
				Connection failure	(1)Reset the alarm. (2)If the alarm occurs again, replace the following cables. ·The wire harness in the robot.
				Module failure (amplifier)	(1)Reset the alarm. (2)If the alarm occurs again, replace controller. Save the CMOS.BIN before replace controller to be safe.
4323	AMPLIFIER OVERLOAD (MOMENT)		Sub Code: Signifies the axis in which the alarm occurred	Setting error	Check the following settings. ·The tools or the mass of the workpieces
				Interference error	Remove interference with the workpiece and peripheral device.
				Setting error	Correct the job whether load late does not exceed 100%.
				Servo control board failure	(1)Check that 24V is generated to the brake bolt of the following terminals. ·Motor brake terminal (2)If the alarm occurs again, replace controller. Save the CMOS.BIN before replace controller to be safe.
				Connection failure	(1)Reset the alarm. (2)If the alarm occurs again, replace the following cables. ·The wire harness in the robot.
				Module failure (amplifier)	(1)Reset the alarm. (2)If the alarm occurs again, replace controller. Save the CMOS.BIN before replace controller to be safe.
				Module failure (converter)	(1)Reset the alarm. (2)If the alarm occurs again, replace controller. Save the CMOS.BIN before replace controller to be safe.

Alarm Number	Alarm Name	Sub Code	Meaning	Cause	Remedy
4324	CONVERTER OVERLOAD			Setting error	Check the settings of the following. ·If the tool or the workpiece used has exceeded the allowable load.
				Setting error	Adjust the job speed. Adjust the acceleration/deceleration of ACC and DEC instructions.
				Module failure (converter)	(1)Reset the alarm. (2)If the alarm occurs again, replace controller. Save the CMOS.BIN before replace controller to be safe.
				Servo control board failure	(1)Reset the alarm. (2)If the alarm occurs again, replace controller. Save the CMOS.BIN before replace controller to be safe.
4326	OVER SPEED		Sub Code: Signifies the axis in which the alarm occurred	Setting error	Check the following settings. ·Reduction in the motion speed
				Connection failure	(1)Reset the alarm. (2)If the alarm occurs again, check that U-, V- and W-phase are appropriately connected.
				Module failure (motor)	(1)Reset the alarm. (2)If the alarm occurs again, replace the motor.
				Servo control board failure	(1)Reset the alarm. (2)If the alarm occurs again, replace controller. Save the CMOS.BIN before replace controller to be safe.
4327	WRONG MOTOR ROTATION		Sub Code: Signifies the axis in which the alarm occurred	Connection failure	(1)Reset the alarm. (2)If the alarm occurs again, check the connection and inserting state of the following cables and connectors. ·The motor power line ·The encoder line
				Connection failure	(1)Reset the alarm. (2)If the alarm occurs again, check the connection and inserting state of the following cables and connectors. ·The power cable connection of the manipulator cable.
				Servo control board failure	(1)Reset the alarm. (2)If the alarm occurs again, replace controller. Save the CMOS.BIN before replace controller to be safe.
4328	SERVO TRACKING ERROR		Sub Code: Signifies the axis in which the alarm occurred	Setting error	Check the settings of the followings. ·Tool file setting ·The tools or the mass of the workpieces
				Interference error	Remove interference with the workpiece and peripheral device.

Alarm Number	Alarm Name	Sub Code	Meaning	Cause	Remedy
				Teaching accelerating/ decelerating speed maximum	Adjust the acceleration/deceleration of ACC and DEC instructions.
				Connection failure	(1)Reset the alarm. (2)If the alarm occurs again, check the connection and inserting state of the following cables and connectors. ·The motor power line ·The encoder line
				Module failure (brake)	(1)Reset the alarm. (2)If the alarm occurs again, replace controller. Save the CMOS.BIN before replace controller to be safe.
				Module failure (amplifier)	(1)Reset the alarm. (2)If the alarm occurs again, replace controller. Save the CMOS.BIN before replace controller to be safe.
				Module failure (motor)	(1)Reset the alarm. (2)If the alarm occurs again, replace the motor.
				Servo control board failure	(1)Reset the alarm. (2)If the alarm occurs again, replace controller. Save the CMOS.BIN before replace controller to be safe.
				Module failure (converter)	(1)Reset the alarm. (2)If the alarm occurs again, replace controller. Save the CMOS.BIN before replace controller to be safe.
4329	SAFETY SPEED ERROR (SERVO)	11	The motion speed at the center of the flange exceeded the specified max. speed.	Setting error	Check the following settings. ·Reduction in the motion speed
				Setting error	(1)Reset the alarm, and then try again. (2)If the alarm occurs again, save the CMOS.BIN in maintenance mode, and then contact your Yaskawa representative about occurrence status (operating procedure).
				Connection failure	(1)Reset the alarm. (2)If the alarm occurs again, replace the motor.
				Module failure (motor)	(1)Reset the alarm. (2)If the alarm occurs again, replace the motor.
				Servo control board failure	(1)Reset the alarm. (2)If the alarm occurs again, replace controller. Save the CMOS.BIN before replace controller to be safe.

Alarm Number	Alarm Name	Sub Code	Meaning	Cause	Remedy
		12	The motion speed at the center of the flange exceeded the specified max. speed.	Setting error	Check the following settings. ·Reduction in the motion speed
				Setting error	(1)Reset the alarm, and then try again. (2)If the alarm occurs again, save the CMOS.BIN in maintenance mode, and then contact your Yaskawa representative about occurrence status (operating procedure).
				Connection failure	(1)Reset the alarm. (2)If the alarm occurs again, check that U-, V- and W-phase are appropriately connected.
				Module failure (motor)	(1)Reset the alarm. (2)If the alarm occurs again, replace the motor.
				Servo control board failure	(1)Reset the alarm. (2)If the alarm occurs again, replace controller. Save the CMOS.BIN before replace controller to be safe.
		21	The motion speed at the center of the control point exceeded the specified max. speed.	Software operation error occurred	Check the following settings. ·Reduction in the motion speed
				Software operation error occurred	(1)Reset the alarm, and then try again. (2)If the alarm occurs again, save the CMOS.BIN in maintenance mode, and then contact your Yaskawa representative about occurrence status (operating procedure).
				Connection failure	(1)Reset the alarm. (2)If the alarm occurs again, check that U-, V- and W-phase are appropriately connected.
				Module failure (motor)	(1)Reset the alarm. (2)If the alarm occurs again, replace the motor.
				Servo control board failure	(1)Reset the alarm. (2)If the alarm occurs again, replace controller. Save the CMOS.BIN before replace controller to be safe.
		22	The motion speed at the center of the control point exceeded the specified max. speed.	Setting error	Check the following settings. ·Reduction in the motion speed
				Setting error	(1)Reset the alarm, and then try again. (2)If the alarm occurs again, save the CMOS.BIN in maintenance mode, and then contact your Yaskawa representative about occurrence status (operating procedure).

Alarm Number	Alarm Name	Sub Code	Meaning	Cause	Remedy
				Connection failure	(1)Reset the alarm. (2)If the alarm occurs again, check that U-, V- and W-phase are appropriately connected.
				Module failure (motor)	(1)Reset the alarm. (2)If the alarm occurs again, replace the motor.
				Servo control board failure	(1)Reset the alarm. (2)If the alarm occurs again, replace controller. Save the CMOS.BIN before replace controller to be safe.
4334	OVERVOLTAGE (CONVERTER)		Sub Code: Signifies the physical No. of converter in which the alarm occurred	Connection failure	(1)Reset the alarm. (2)If the alarm occurs again, replace controller. Save the CMOS.BIN before replace controller to be safe.
				Setting error	Check the following settings. ·The tools or the mass of the workpieces
				Voltage failure	Modify the primary breaker voltage to the specified voltage 200V(+10% to 15%).
				Module failure (Regenerative resistor)	(1)Reset the alarm. (2)If the alarm occurs again, replace controller. Save the CMOS.BIN before replace controller to be safe.
				Module failure (converter)	(1)Reset the alarm. (2)If the alarm occurs again, replace controller. Save the CMOS.BIN before replace controller to be safe.
				Servo control board failure	(1)Reset the alarm. (2)If the alarm occurs again, replace controller. Save the CMOS.BIN before replace controller to be safe.
4336	OPEN PHASE (CONVERTER)		Sub Code: Signifies the physical No. of converter in which the alarm occurred	Connection failure	(1)Reset the alarm. (2)If the alarm occurs again, replace controller. Save the CMOS.BIN before replace controller to be safe.
				Voltage failure	Modify the primary breaker voltage to the specified voltage 200V(+10% to 15%).
				Module failure (converter)	(1)Reset the alarm. (2)If the alarm occurs again, replace controller. Save the CMOS.BIN before replace controller to be safe.
				Servo control board failure	(1)Reset the alarm. (2)If the alarm occurs again, replace controller. Save the CMOS.BIN before replace controller to be safe.

Alarm Number	Alarm Name	Sub Code	Meaning	Cause	Remedy
4337	OVERCURRENT (AMP)		Sub Code: Signifies the axis in which the alarm occurred	Connection failure	(1)Reset the alarm. (2)If the alarm occurs again, replace controller. Save the CMOS.BIN before replace controller to be safe.
				Connection failure	(1)Reset the alarm. (2)If the alarm occurs again, replace the following cables. ·Manipulator cable ·Supply cable
				Module failure (amplifier)	(1)Reset the alarm. (2)If the alarm occurs again, replace controller. Save the CMOS.BIN before replace controller to be safe.
				Module failure (motor)	(1)Reset the alarm. (2)If the alarm occurs again, replace the motor.
				Servo control board failure	(1)Reset the alarm. (2)If the alarm occurs again, replace controller. Save the CMOS.BIN before replace controller to be safe.
4338	REGENERATIVE TROUBLE (CONVERTER)		Sub Code: Signifies the axis in which the alarm occurred	Connection failure	(1)Reset the alarm. (2)If the alarm occurs again, replace controller. Save the CMOS.BIN before replace controller to be safe.
				Module failure (Regenerative resistor)	(1)Reset the alarm. (2)If the alarm occurs again, replace controller. Save the CMOS.BIN before replace controller to be safe.
				Module failure (converter)	(1)Reset the alarm. (2)If the alarm occurs again, replace controller. Save the CMOS.BIN before replace controller to be safe.
				Servo control board failure	(1)Reset the alarm. (2)If the alarm occurs again, replace controller. Save the CMOS.BIN before replace controller to be safe.
				Overloading	Check that the load does not exceed the allowable limit.
4341	DISLOCATION DETECT		Sub Code: Signifies the axis in which the alarm occurred	Interference error	Remove the following interferences. ·The interferences to the jigs of Robot. ·The interferences to the jigs of workpieces.
				Parts damage	Check the following parts. ·damage of spring ·damage of bushing
				Software operation error occurred	Check the following settings. ·The tool information

Alarm Number	Alarm Name	Sub Code	Meaning	Cause	Remedy
4344	LINEAR SERVOFLOAT TRACKING ERROR			Software operation error occurred	Confirm the job settings so that excess load would not be applied to the axis in the linear servo float.
4345	LNK SERVOFLOAT EXECUTE ERROR			Setting error	Confirm the job settings so that excess load would not be applied to the axis in the linear servo float.
4346	LNK SERVOFLOAT TRQ LIMIT ERROR			Setting error	Check the limit torque of the link servo float condition file.
4347	LNR SERVOFLOAT TRQ LIMIT ERROR			Setting error	Check the limit torque of the link servo float condition file.
4348	LNR SERVOFLOAT COORD TYPE ERROR			Setting error	Check the setting file of the job and the linear servo float.
4349	LNR SERVOFLOAT TOOL POSE ERROR			Setting error	Check the setting file of the job and the linear servo float.
4350	LNR SERVOFLOAT EXECUTE ERROR			Setting error	Check the settings for jobs.
4351	DRIVE BELT SNAP DETECT		Sub Code: Signifies the axis in which the alarm occurred	Connection failure	Check that the driving belt is not broken.
				Driving belt failure	Check the driving belt.
4352	TWIN DRIVE OVER DEVIATION		Sub Code: Signifies the axis in which the alarm occurred	Connection failure	(1)Reset the alarm. (2)If the alarm occurs again, replace controller. Save the CMOS.BIN before replace controller to be safe.
				Cable (failure) (motor power cable)	(1)Check U-, V- and W-phase of the motor power cable disconnection. (2)If disconnection is found, replace the motor power cable.
				Cable (failure) (motor brake cable)	(1) Check that the motor brake wire is not disconnected. (2) If disconnected, replace the motor brake wire.
				Servo control board failure	(1)Reset the alarm. (2)If the alarm occurs again, replace controller. Save the CMOS.BIN before replace controller to be safe.
				Module failure (amplifier)	(1)Reset the alarm. (2)If the alarm occurs again, replace controller. Save the CMOS.BIN before replace controller to be safe.
				Module failure (motor)	(1)Reset the alarm. (2)If the alarm occurs again, replace controller. Save the CMOS.BIN before replace controller to be safe.
4353	DEFECTIVE TAUGHT POINT (ENDLESS)		Sub Code: Signifies the axis in which the alarm occurred	Setting error	Check the following settings. ·Setting of the command soft (JOB) ·MRESET instruction to corresponding axis

Alarm Number	Alarm Name	Sub Code	Meaning	Cause	Remedy
				Servo control board failure	(1)Reset the alarm. (2)If the alarm occurs again, replace controller. Save the CMOS.BIN before replace controller to be safe.
4355	EXTERNAL PRES DETECT (SERVOFLOAT)			Setting error	Check the settings for jobs.
4400	NOT READY (ARITH)	1	The arithmetic process for motion control did not complete within regulated time. No motion command was prepared.	Software operation error occurred	(1)Reset the alarm, and then try again. (2)If the alarm occurs again, save the CMOS.BIN in maintenance mode, and then contact your Yaskawa representative about occurrence status (operating procedure).
		2	The arithmetic processing section is not ready for JOG operation.	Software operation error occurred	(1)Reset the alarm, and then try again. (2)If the alarm occurs again, save the CMOS.BIN in maintenance mode, and then contact your Yaskawa representative about occurrence status (operating procedure).
		3	The arithmetic processing section is not ready for the playback operation.	Software operation error occurred	(1)Reset the alarm, and then try again. (2)If the alarm occurs again, save the CMOS.BIN in maintenance mode, and then contact your Yaskawa representative about occurrence status (operating procedure).
		4	The prereading processing in the arithmetic processing section has not completed.	Software operation error occurred	(1)Reset the alarm, and then try again. (2)If the alarm occurs again, save the CMOS.BIN in maintenance mode, and then contact your Yaskawa representative about occurrence status (operating procedure).
		5	The arithmetic processing section is not ready for the timer follow-up of the conveyor tracking function.	Software operation error occurred	(1)Reset the alarm, and then try again. (2)If the alarm occurs again, save the CMOS.BIN in maintenance mode, and then contact your Yaskawa representative about occurrence status (operating procedure).
4401	SEQUENCE TASK CONTR ERROR	1	Unused A_BANK does not exist in the prereading processing of move instruction.	Software operation error occurred	(1)Reset the alarm, and then try again. (2)If the alarm occurs again, save the CMOS.BIN in maintenance mode, and then contact your Yaskawa representative about occurrence status (operating procedure).
		2	Unused bank priority does not exist in the prereading processing of move instruction.	Software operation error occurred	(1)Reset the alarm, and then try again. (2)If the alarm occurs again, save the CMOS.BIN in maintenance mode, and then contact your Yaskawa representative about occurrence status (operating procedure).
		5	A_BANK pointer is not set.	Software operation error occurred	(1)Reset the alarm, and then try again. (2)If the alarm occurs again, save the CMOS.BIN in maintenance mode, and then contact your Yaskawa representative about occurrence status (operating procedure).

Alarm Number	Alarm Name	Sub Code	Meaning	Cause	Remedy
		6	A_BANK conversion could not be performed.	Software operation error occurred	(1)Reset the alarm, and then try again. (2)If the alarm occurs again, save the CMOS.BIN in maintenance mode, and then contact your Yaskawa representative about occurrence status (operating procedure).
		7	The specified A_BANK number does not exist.	Software operation error occurred	(1)Reset the alarm, and then try again. (2)If the alarm occurs again, save the CMOS.BIN in maintenance mode, and then contact your Yaskawa representative about occurrence status (operating procedure).
		20	An error occurred when system number (MSS) was obtained.	Software operation error occurred	(1)Reset the alarm, and then try again. (2)If the alarm occurs again, save the CMOS.BIN in maintenance mode, and then contact your Yaskawa representative about occurrence status (operating procedure).
		21	An error occurred in RMS960 system call.	Software operation error occurred	(1)Reset the alarm, and then try again. (2)If the alarm occurs again, save the CMOS.BIN in maintenance mode, and then contact your Yaskawa representative about occurrence status (operating procedure).
		22	Undefined interrupt command was received.	Software operation error occurred	(1)Reset the alarm, and then try again. (2)If the alarm occurs again, save the CMOS.BIN in maintenance mode, and then contact your Yaskawa representative about occurrence status (operating procedure).
		23	Job start condition is not defined.	Software operation error occurred	(1)Reset the alarm, and then try again. (2)If the alarm occurs again, save the CMOS.BIN in maintenance mode, and then contact your Yaskawa representative about occurrence status (operating procedure).
		24	An error occurred in instruction prefetch queue operation.	Software operation error occurred	(1)Reset the alarm, and then try again. (2)If the alarm occurs again, save the CMOS.BIN in maintenance mode, and then contact your Yaskawa representative about occurrence status (operating procedure).
		26	Intermediate code is not defined.	Software operation error occurred	(1)Reset the alarm, and then try again. (2)If the alarm occurs again, save the CMOS.BIN in maintenance mode, and then contact your Yaskawa representative about occurrence status (operating procedure).
		29	Instruction prereading processing has not been completed normally.	Software operation error occurred	(1)Reset the alarm, and then try again. (2)If the alarm occurs again, save the CMOS.BIN in maintenance mode, and then contact your Yaskawa representative about occurrence status (operating procedure).

Alarm Number	Alarm Name	Sub Code	Meaning	Cause	Remedy
		30	An error occurred in job data change.	Software operation error occurred	(1)Reset the alarm, and then try again. (2)If the alarm occurs again, save the CMOS.BIN in maintenance mode, and then contact your Yaskawa representative about occurrence status (operating procedure).
		31	The specified sequence number at job execution start is incorrect.	Software operation error occurred	(1)Reset the alarm, and then try again. (2)If the alarm occurs again, save the CMOS.BIN in maintenance mode, and then contact your Yaskawa representative about occurrence status (operating procedure).
		32	The added area for interruption command is incorrect.	Software operation error occurred	(1)Reset the alarm, and then try again. (2)If the alarm occurs again, save the CMOS.BIN in maintenance mode, and then contact your Yaskawa representative about occurrence status (operating procedure).
		33	System number (MSS) for interruption command is incorrect.	Software operation error occurred	(1)Reset the alarm, and then try again. (2)If the alarm occurs again, save the CMOS.BIN in maintenance mode, and then contact your Yaskawa representative about occurrence status (operating procedure).
		38	An error occurred at start of twin synchronous operation.	Software operation error occurred	(1)Reset the alarm, and then try again. (2)If the alarm occurs again, save the CMOS.BIN in maintenance mode, and then contact your Yaskawa representative about occurrence status (operating procedure).
		39	An error occurred when SYNC specification was reset.	Software operation error occurred	(1)Reset the alarm, and then try again. (2)If the alarm occurs again, save the CMOS.BIN in maintenance mode, and then contact your Yaskawa representative about occurrence status (operating procedure).
		41	An error occurred in occupation control group setting in MOTION section.	Software operation error occurred	(1)Reset the alarm, and then try again. (2)If the alarm occurs again, save the CMOS.BIN in maintenance mode, and then contact your Yaskawa representative about occurrence status (operating procedure).
		45	An error occurred in path/trace control.	Software operation error occurred	(1)Reset the alarm, and then try again. (2)If the alarm occurs again, save the CMOS.BIN in maintenance mode, and then contact your Yaskawa representative about occurrence status (operating procedure).
		47	An error occurred when waiting for a completion of main system task (job) in SYNC specification.	Software operation error occurred	(1)Reset the alarm, and then try again. (2)If the alarm occurs again, save the CMOS.BIN in maintenance mode, and then contact your Yaskawa representative about occurrence status (operating procedure).

Alarm Number	Alarm Name	Sub Code	Meaning	Cause	Remedy
		48	An attempt was made to execute an instruction that could not be executed at line sequence execution.	Software operation error occurred	(1)Reset the alarm, and then try again. (2)If the alarm occurs again, save the CMOS.BIN in maintenance mode, and then contact your Yaskawa representative about occurrence status (operating procedure).
		49	An error occurred when during the instruction data acquisition process.	Software operation error occurred	(1)Reset the alarm, and then try again. (2)If the alarm occurs again, save the CMOS.BIN in maintenance mode, and then contact your Yaskawa representative about occurrence status (operating procedure).
		80	An exceptional error occurred in job execution process.	Software operation error occurred	(1)Reset the alarm, and then try again. (2)If the alarm occurs again, save the CMOS.BIN in maintenance mode, and then contact your Yaskawa representative about occurrence status (operating procedure).
		100	Main processing command is incorrect in prereading processing.	Software operation error occurred	(1)Reset the alarm, and then try again. (2)If the alarm occurs again, save the CMOS.BIN in maintenance mode, and then contact your Yaskawa representative about occurrence status (operating procedure).
		101	Subprocessing command is incorrect in prereading processing.	Software operation error occurred	(1)Reset the alarm, and then try again. (2)If the alarm occurs again, save the CMOS.BIN in maintenance mode, and then contact your Yaskawa representative about occurrence status (operating procedure).
		102	Prereading processing has not been completed at job execution.	Software operation error occurred	(1)Reset the alarm, and then try again. (2)If the alarm occurs again, save the CMOS.BIN in maintenance mode, and then contact your Yaskawa representative about occurrence status (operating procedure).
		103	A_BANK conversion has not been completed.	Software operation error occurred	(1)Reset the alarm, and then try again. (2)If the alarm occurs again, save the CMOS.BIN in maintenance mode, and then contact your Yaskawa representative about occurrence status (operating procedure).
		104	System number (MSS) is incorrect in prereading processing.	Software operation error occurred	(1)Reset the alarm, and then try again. (2)If the alarm occurs again, save the CMOS.BIN in maintenance mode, and then contact your Yaskawa representative about occurrence status (operating procedure).
		105	An error occurred in instruction prefetch queue operation in prereading processing.	Software operation error occurred	(1)Reset the alarm, and then try again. (2)If the alarm occurs again, save the CMOS.BIN in maintenance mode, and then contact your Yaskawa representative about occurrence status (operating procedure).

Alarm Number	Alarm Name	Sub Code	Meaning	Cause	Remedy
		106	An error occurred at IES switching in prereading processing.	Software operation error occurred	(1)Reset the alarm, and then try again. (2)If the alarm occurs again, save the CMOS.BIN in maintenance mode, and then contact your Yaskawa representative about occurrence status (operating procedure).
4402	UNDEFINED COMMAND (ARITH)			Software operation error occurred	(1)Reset the alarm, and then try again. (2)Check the following settings. ·the base-axis position must be registered for the system with base-axis MOVJ P00001 BP00001 (3)If the alarm occurs again, save the CMOS.BIN in maintenance mode, and then contact your Yaskawa representative about occurrence status (operating procedure).
4404	ARITHMETIC ERROR	8	Interpolation such as linear and circular interpolation cannot be performed with this manipulator.	Setting error	(1)Check the following settings. ·Change the step (move instruction), where the alarm occurred, to MOVJ.
		10	The setting of the form data for Flip/No Flip is not "B-axis Angle".	Setting error	(1)Check the following settings. ·Set "1" to "S2C658: Type data detail settings".
		11	An attempt was made to pass the B-axis zero degree position (singular area).	Setting error	(1)Check the following settings. ·Check the teaching position of the job so that the manipulator does not pass the B-axis zero degree position (singular area).
4406	GROUP AXIS CONTROL ERROR	1	Designation error for master and slave	Software operation error occurred	(1)Reset the alarm, and then try again. (2)If the alarm occurs again, save the CMOS.BIN in maintenance mode, and then contact your Yaskawa representative about occurrence status (operating procedure).
		2	Slave designation error	Software operation error occurred	(1)Reset the alarm, and then try again. (2)If the alarm occurs again, save the CMOS.BIN in maintenance mode, and then contact your Yaskawa representative about occurrence status (operating procedure).
		3	Slave interpolation error	Software operation error occurred	(1)Reset the alarm, and then try again. (2)If the alarm occurs again, save the CMOS.BIN in maintenance mode, and then contact your Yaskawa representative about occurrence status (operating procedure).
		4	No designation of master axis	Software operation error occurred	(1)Reset the alarm, and then try again. (2)If the alarm occurs again, save the CMOS.BIN in maintenance mode, and then contact your Yaskawa representative about occurrence status (operating procedure).

Alarm Number	Alarm Name	Sub Code	Meaning	Cause	Remedy
		6	Master-axis designation error for JOG motion	Software operation error occurred	(1)Reset the alarm, and then try again. (2)If the alarm occurs again, save the CMOS.BIN in maintenance mode, and then contact your Yaskawa representative about occurrence status (operating procedure).
		7	Slave-axis designation error for JOG motion	Software operation error occurred	(1)Reset the alarm, and then try again. (2)If the alarm occurs again, save the CMOS.BIN in maintenance mode, and then contact your Yaskawa representative about occurrence status (operating procedure).
		8	Occupation control error	Software operation error occurred	(1)Reset the alarm, and then try again. (2)If the alarm occurs again, save the CMOS.BIN in maintenance mode, and then contact your Yaskawa representative about occurrence status (operating procedure).
		9	Designation error of occupation control for JOG motion	Software operation error occurred	(1)Reset the alarm, and then try again. (2)If the alarm occurs again, save the CMOS.BIN in maintenance mode, and then contact your Yaskawa representative about occurrence status (operating procedure).
		10	Designation error of occupation control for Bank position	Software operation error occurred	(1)Reset the alarm, and then try again. (2)If the alarm occurs again, save the CMOS.BIN in maintenance mode, and then contact your Yaskawa representative about occurrence status (operating procedure).
		11	Designation error of occupation control group for tracking motion	Software operation error occurred	(1)Reset the alarm, and then try again. (2)If the alarm occurs again, save the CMOS.BIN in maintenance mode, and then contact your Yaskawa representative about occurrence status (operating procedure).
		12	No master and slave designated for tracking motion	Software operation error occurred	(1)Reset the alarm, and then try again. (2)If the alarm occurs again, save the CMOS.BIN in maintenance mode, and then contact your Yaskawa representative about occurrence status (operating procedure).
4407	TWO STEPS SAME POSITION (CIRC)			Setting error	(1)Check the following settings. -Check the settings for teaching position of circular interpolation steps so that each point is different.
4409	TWO STEPS SAME POSITION (3 STEPS)			Setting error	(1)Check the following settings. -Check the settings for three taught points to create an user coordinate system so that each point is different.
4414	EXCESSIVE SEGMENT (LOW/HIGH)		Sub Code: Control group and axis	Setting error	(1)Reduce the speed in the step where the alarm occurred. (2)Change the move instruction to joint interpolation (MOVJ). * Be careful to the peripheral interference since its movement changes.

Alarm Number	Alarm Name	Sub Code	Meaning	Cause	Remedy
4416	PULSE LIMIT (MIN./MAX.)		Sub Code: Control group and axis	Setting error	(1)Check the following settings. ·Perform the teaching again to correct positions for manipulators so that the step where the alarm occurred is within the motion range.
4418	CUBE LIMIT (MIN./MAX.)		Sub Code: Control group and XYZ	Setting error	(1)Check the following settings. ·Perform the teaching again to correct positions for manipulators so that the step where the alarm occurred is within the motion range.
4420	SPECIAL SOFTLIMIT (MIN./MAX.)		Sub Code: Control group and axis	Setting error	(1)Check the following settings. ·Perform the teaching again to correct positions for manipulators so that the step where the alarm occurred is within the motion range.
4422	MECHANICAL INTERFERENCE (MIN./MAX.)		Sub Code: Control group and axis	Setting error	(1)Check the following settings. ·Perform the teaching again to correct positions for manipulators so that the step where the alarm occurred is within the motion range.
4424	SPECIAL MECHANICAL INTRF(MIN./MAX.)		Sub Code: Control group and axis	Setting error	(1)Check the following settings. ·Perform the teaching again to correct positions for manipulators so that the step where the alarm occurred is within the motion range. (2) If the manipulator is stopped near the interference area by servo OFF, it may interfere with the interference area. In this case, execute the following operations to disable the special mechanical interference check and move each part out of the interference area. - Change the mode to "TEACH" - To display LIMIT RELEASE window, select the main menu [ROBOT] and then [LIMIT RELEASE] - Change the setting for ALL LIMIT RELEASE from "INVALID" to "VALID" by [SELECT] key - Move each part out of the interference area - Change the setting for ALL LIMIT RELEASE from "VALID" to "INVALID" by [SELECT] key NOTE) Be sure to check the operation direction since the above operations enable manipulator's parts to interfere with each other.
4426	PULSE MECHANICAL LIMIT(MIN./MAX.)		Sub Code: Control group and axis	Setting error	(1)Check the following settings. ·Perform the teaching again to correct positions for manipulators so that the step where the alarm occurred is within the motion range.
4428	SEGMENT CONTROL ERROR	1	RT-buffer control command error	Software operation error occurred	(1)Reset the alarm, and then try again. (2)If the alarm occurs again, save the CMOS.BIN in maintenance mode, and then contact your Yaskawa representative about occurrence status (operating procedure).

Alarm Number	Alarm Name	Sub Code	Meaning	Cause	Remedy
		2	Segment-receiving control command error	Software operation error occurred	(1)Reset the alarm, and then try again. (2)If the alarm occurs again, save the CMOS.BIN in maintenance mode, and then contact your Yaskawa representative about occurrence status (operating procedure).
		3	No bank priority	Software operation error occurred	(1)Reset the alarm, and then try again. (2)If the alarm occurs again, save the CMOS.BIN in maintenance mode, and then contact your Yaskawa representative about occurrence status (operating procedure).
		4	Answer error at MOVE simulating	Software operation error occurred	(1)Reset the alarm, and then try again. (2)If the alarm occurs again, save the CMOS.BIN in maintenance mode, and then contact your Yaskawa representative about occurrence status (operating procedure).
		5	The value of bank_refresh_flag(x) exceeded its limit.	Software operation error occurred	(1)Reset the alarm, and then try again. (2)If the alarm occurs again, save the CMOS.BIN in maintenance mode, and then contact your Yaskawa representative about occurrence status (operating procedure).
		8	RT-buffer tracking option error	Software operation error occurred	(1)Reset the alarm, and then try again. (2)If the alarm occurs again, save the CMOS.BIN in maintenance mode, and then contact your Yaskawa representative about occurrence status (operating procedure).
		9	The segment was received although the previous segment had not been sent.	Software operation error occurred	(1)Reset the alarm, and then try again. (2)If the alarm occurs again, save the CMOS.BIN in maintenance mode, and then contact your Yaskawa representative about occurrence status (operating procedure).
		10	Segment creation is requested before segment-receiving is completed.	Software operation error occurred	(1)Reset the alarm, and then try again. (2)If the alarm occurs again, save the CMOS.BIN in maintenance mode, and then contact your Yaskawa representative about occurrence status (operating procedure).
4429	WRONG SPECIFIED CONTROL GROUP	1	Control group not designated	Software operation error occurred	(1)Reset the alarm, and then try again. (2)If the alarm occurs again, save the CMOS.BIN in maintenance mode, and then contact your Yaskawa representative about occurrence status (operating procedure).
		2	Slave control-group error	Software operation error occurred	(1)Reset the alarm, and then try again. (2)If the alarm occurs again, save the CMOS.BIN in maintenance mode, and then contact your Yaskawa representative about occurrence status (operating procedure).

Alarm Number	Alarm Name	Sub Code	Meaning	Cause	Remedy
		3	Master control-group error	Software operation error occurred	(1)Reset the alarm, and then try again. (2)If the alarm occurs again, save the CMOS.BIN in maintenance mode, and then contact your Yaskawa representative about occurrence status (operating procedure).
		4	Master and Slave control-group error	Software operation error occurred	(1)Reset the alarm, and then try again. (2)If the alarm occurs again, save the CMOS.BIN in maintenance mode, and then contact your Yaskawa representative about occurrence status (operating procedure).
		5	Control-group error for a job file	Software operation error occurred	(1)Reset the alarm, and then try again. (2)If the alarm occurs again, save the CMOS.BIN in maintenance mode, and then contact your Yaskawa representative about occurrence status (operating procedure).
		6	Control-group error for a user coordinate file	Software operation error occurred	(1)Reset the alarm, and then try again. (2)If the alarm occurs again, save the CMOS.BIN in maintenance mode, and then contact your Yaskawa representative about occurrence status (operating procedure).
		7	Control-group error for a calibration file between manipulators	Software operation error occurred	(1)Reset the alarm, and then try again. (2)If the alarm occurs again, save the CMOS.BIN in maintenance mode, and then contact your Yaskawa representative about occurrence status (operating procedure).
		8	Control-group error for a tool calibration file	Software operation error occurred	(1)Reset the alarm, and then try again. (2)If the alarm occurs again, save the CMOS.BIN in maintenance mode, and then contact your Yaskawa representative about occurrence status (operating procedure).
		10	Control-group error for prereading-calculation start point (for adv_st_pos)	Software operation error occurred	(1)Reset the alarm, and then try again. (2)If the alarm occurs again, save the CMOS.BIN in maintenance mode, and then contact your Yaskawa representative about occurrence status (operating procedure).
		11	Control-group error for the current-value preset position	Software operation error occurred	(1)Reset the alarm, and then try again. (2)If the alarm occurs again, save the CMOS.BIN in maintenance mode, and then contact your Yaskawa representative about occurrence status (operating procedure).
		12	Control-group error for the conveyor prereading-calculation start point	Software operation error occurred	(1)Reset the alarm, and then try again. (2)If the alarm occurs again, save the CMOS.BIN in maintenance mode, and then contact your Yaskawa representative about occurrence status (operating procedure).

Alarm Number	Alarm Name	Sub Code	Meaning	Cause	Remedy
		13	Occupation control-group error	Software operation error occurred	(1)Reset the alarm, and then try again. (2)If the alarm occurs again, save the CMOS.BIN in maintenance mode, and then contact your Yaskawa representative about occurrence status (operating procedure).
		18	Control-group error for the prereading-calculation start point (for dm_st_pos)	Software operation error occurred	(1)Reset the alarm, and then try again. (2)If the alarm occurs again, save the CMOS.BIN in maintenance mode, and then contact your Yaskawa representative about occurrence status (operating procedure).
		19	Control-group error for prereading-calculation start point (for dm_st_pos)	Software operation error occurred	(1)Reset the alarm, and then try again. (2)If the alarm occurs again, save the CMOS.BIN in maintenance mode, and then contact your Yaskawa representative about occurrence status (operating procedure).
4430	CPU COMMUNICATION ERROR	1	Interrupt processing error between MOTION section and system control section	Software operation error occurred	(1)Reset the alarm, and then try again. (2)If the alarm occurs again, save the CMOS.BIN in maintenance mode, and then contact your Yaskawa representative about occurrence status (operating procedure).
		2	Interrupt processing error between MOTION section and SL#1	Software operation error occurred	(1)Reset the alarm, and then try again. (2)If the alarm occurs again, save the CMOS.BIN in maintenance mode, and then contact your Yaskawa representative about occurrence status (operating procedure).
		3	Interrupt processing error between MOTION section and SL#2	Software operation error occurred	(1)Reset the alarm, and then try again. (2)If the alarm occurs again, save the CMOS.BIN in maintenance mode, and then contact your Yaskawa representative about occurrence status (operating procedure).
		4	Interrupt processing error between MOTION section and SL#3	Software operation error occurred	(1)Reset the alarm, and then try again. (2)If the alarm occurs again, save the CMOS.BIN in maintenance mode, and then contact your Yaskawa representative about occurrence status (operating procedure).
		5	Interrupt processing error between MOTION section and SL#4	Software operation error occurred	(1)Reset the alarm, and then try again. (2)If the alarm occurs again, save the CMOS.BIN in maintenance mode, and then contact your Yaskawa representative about occurrence status (operating procedure).
		6	Interrupt processing error between MOTION section and CV#1	Software operation error occurred	(1)Reset the alarm, and then try again. (2)If the alarm occurs again, save the CMOS.BIN in maintenance mode, and then contact your Yaskawa representative about occurrence status (operating procedure).

Alarm Number	Alarm Name	Sub Code	Meaning	Cause	Remedy
		7	Interrupt processing error between MOTION section and CV#2	Software operation error occurred	(1)Reset the alarm, and then try again. (2)If the alarm occurs again, save the CMOS.BIN in maintenance mode, and then contact your Yaskawa representative about occurrence status (operating procedure).
4431	JHM ERROR	1	An error occurred in JMS system call when an attempt was made to open a job.	Software operation error occurred	(1)Reset the alarm, and then try again. (2)If the alarm occurs again, save the CMOS.BIN in maintenance mode, and then contact your Yaskawa representative about occurrence status (operating procedure).
		2	No space was found in job handle value storage area when an attempt was made to open a job.	Software operation error occurred	(1)Reset the alarm, and then try again. (2)If the alarm occurs again, save the CMOS.BIN in maintenance mode, and then contact your Yaskawa representative about occurrence status (operating procedure).
		3	No job handle was found.	Software operation error occurred	(1)Reset the alarm, and then try again. (2)If the alarm occurs again, save the CMOS.BIN in maintenance mode, and then contact your Yaskawa representative about occurrence status (operating procedure).
		4	Job control proprietary is incorrect.	Software operation error occurred	(1)Reset the alarm, and then try again. (2)If the alarm occurs again, save the CMOS.BIN in maintenance mode, and then contact your Yaskawa representative about occurrence status (operating procedure).
		5	Job control proprietary could not be changed.	Software operation error occurred	(1)Reset the alarm, and then try again. (2)If the alarm occurs again, save the CMOS.BIN in maintenance mode, and then contact your Yaskawa representative about occurrence status (operating procedure).
		6	An error occurred in exclusive control.	Software operation error occurred	(1)Reset the alarm, and then try again. (2)If the alarm occurs again, save the CMOS.BIN in maintenance mode, and then contact your Yaskawa representative about occurrence status (operating procedure).
4432	INSTRUCTION INTERPRETER ERROR	1	The intermediate code of the instruction that is to be executed is incorrect.	Software operation error occurred	(1)Reset the alarm, and then try again. (2)If the alarm occurs again, save the CMOS.BIN in maintenance mode, and then contact your Yaskawa representative about occurrence status (operating procedure).
		3	Destination (variable) tag arrangement is incorrect.	Software operation error occurred	(1)Reset the alarm, and then try again. (2)If the alarm occurs again, save the CMOS.BIN in maintenance mode, and then contact your Yaskawa representative about occurrence status (operating procedure).
		4	Tag data type is incorrect.	Software operation error occurred	(1)Reset the alarm, and then try again. (2)If the alarm occurs again, save the CMOS.BIN in maintenance mode, and then contact your Yaskawa representative about occurrence status (operating procedure).

Alarm Number	Alarm Name	Sub Code	Meaning	Cause	Remedy
		5	Box number is incorrect.	Software operation error occurred	(1)Reset the alarm, and then try again. (2)If the alarm occurs again, save the CMOS.BIN in maintenance mode, and then contact your Yaskawa representative about occurrence status (operating procedure).
		6	An error occurred in block separation processing of intermediate code.	Software operation error occurred	(1)Reset the alarm, and then try again. (2)If the alarm occurs again, save the CMOS.BIN in maintenance mode, and then contact your Yaskawa representative about occurrence status (operating procedure).
		8	Box number definition is duplicated.	Software operation error occurred	(1)Reset the alarm, and then try again. (2)If the alarm occurs again, save the CMOS.BIN in maintenance mode, and then contact your Yaskawa representative about occurrence status (operating procedure).
		9	Undefined instruction was found at block separation of intermediate code.	Software operation error occurred	(1)Reset the alarm, and then try again. (2)If the alarm occurs again, save the CMOS.BIN in maintenance mode, and then contact your Yaskawa representative about occurrence status (operating procedure).
		10	IPRM is not set.	Software operation error occurred	(1)Reset the alarm, and then try again. (2)If the alarm occurs again, save the CMOS.BIN in maintenance mode, and then contact your Yaskawa representative about occurrence status (operating procedure).
		11	An error occurred in tag data search process.	Software operation error occurred	(1)Reset the alarm, and then try again. (2)If the alarm occurs again, save the CMOS.BIN in maintenance mode, and then contact your Yaskawa representative about occurrence status (operating procedure).
		12	An error occurred move instruction search process.	Software operation error occurred	(1)Reset the alarm, and then try again. (2)If the alarm occurs again, save the CMOS.BIN in maintenance mode, and then contact your Yaskawa representative about occurrence status (operating procedure).
		14	Variable information does not exist.	Software operation error occurred	(1)Reset the alarm, and then try again. (2)If the alarm occurs again, save the CMOS.BIN in maintenance mode, and then contact your Yaskawa representative about occurrence status (operating procedure).
		16	An error occurred at position file data reading.	Software operation error occurred	(1)Reset the alarm, and then try again. (2)If the alarm occurs again, save the CMOS.BIN in maintenance mode, and then contact your Yaskawa representative about occurrence status (operating procedure).

Alarm Number	Alarm Name	Sub Code	Meaning	Cause	Remedy
		17	Variable data type is not defined.	Software operation error occurred	(1)Reset the alarm, and then try again. (2)If the alarm occurs again, save the CMOS.BIN in maintenance mode, and then contact your Yaskawa representative about occurrence status (operating procedure).
		18	An instruction is included with incorrect intermediate code in expression instruction.	Software operation error occurred	(1)Reset the alarm, and then try again. (2)If the alarm occurs again, save the CMOS.BIN in maintenance mode, and then contact your Yaskawa representative about occurrence status (operating procedure).
		19	The syntax in expression instruction is incorrect.	Software operation error occurred	(1)Reset the alarm, and then try again. (2)If the alarm occurs again, save the CMOS.BIN in maintenance mode, and then contact your Yaskawa representative about occurrence status (operating procedure).
		20	The tag data length is zero when tag data is read.	Software operation error occurred	(1)Reset the alarm, and then try again. (2)If the alarm occurs again, save the CMOS.BIN in maintenance mode, and then contact your Yaskawa representative about occurrence status (operating procedure).
		22	The object to be processed was secret variable in position file control process, so it could not be processed.	Software operation error occurred	(1)Reset the alarm, and then try again. (2)If the alarm occurs again, save the CMOS.BIN in maintenance mode, and then contact your Yaskawa representative about occurrence status (operating procedure).
		23	The object to be processed was position type variable in position file control process, so it could not be processed.	Software operation error occurred	(1)Reset the alarm, and then try again. (2)If the alarm occurs again, save the CMOS.BIN in maintenance mode, and then contact your Yaskawa representative about occurrence status (operating procedure).
		24	Job argument settings do not match when a variable is given and/or taken between jobs.	Software operation error occurred	(1)Reset the alarm, and then try again. (2)If the alarm occurs again, save the CMOS.BIN in maintenance mode, and then contact your Yaskawa representative about occurrence status (operating procedure).
		25	An attempt was made to perform undefined operation at four-rule operation instruction.	Software operation error occurred	(1)Reset the alarm, and then try again. (2)If the alarm occurs again, save the CMOS.BIN in maintenance mode, and then contact your Yaskawa representative about occurrence status (operating procedure).
		26	Arithmetic stack used for expression operation exceeded.	Software operation error occurred	(1)Reset the alarm, and then try again. (2)If the alarm occurs again, save the CMOS.BIN in maintenance mode, and then contact your Yaskawa representative about occurrence status (operating procedure).

Alarm Number	Alarm Name	Sub Code	Meaning	Cause	Remedy
		27	Arithmetic stack used for expression operation is empty.	Software operation error occurred	(1)Reset the alarm, and then try again. (2)If the alarm occurs again, save the CMOS.BIN in maintenance mode, and then contact your Yaskawa representative about occurrence status (operating procedure).
		28	Operation items are lacking in expression operation and operation processing cannot be performed.	Software operation error occurred	(1)Reset the alarm, and then try again. (2)If the alarm occurs again, save the CMOS.BIN in maintenance mode, and then contact your Yaskawa representative about occurrence status (operating procedure).
		29	Sub instruction which has EXEC process exceeded the maximum number.	Software operation error occurred	(1)Reset the alarm, and then try again. (2)If the alarm occurs again, save the CMOS.BIN in maintenance mode, and then contact your Yaskawa representative about occurrence status (operating procedure).
		254	Access mechanism for old parameters is used.	Software operation error occurred	(1)Reset the alarm, and then try again. (2)If the alarm occurs again, save the CMOS.BIN in maintenance mode, and then contact your Yaskawa representative about occurrence status (operating procedure).
		255	An exceptional error occurred.	Software operation error occurred	(1)Reset the alarm, and then try again. (2)If the alarm occurs again, save the CMOS.BIN in maintenance mode, and then contact your Yaskawa representative about occurrence status (operating procedure).
4433	UNDEFINED GLOBAL VARIABLE	0	The set data for byte type variable area is incorrect.	Software operation error occurred	(1)Reset the alarm, and then try again. (2)If the alarm occurs again, save the CMOS.BIN in maintenance mode, and then contact your Yaskawa representative about occurrence status (operating procedure).
		1	The set data for integer type variable area is incorrect.	Software operation error occurred	(1)Reset the alarm, and then try again. (2)If the alarm occurs again, save the CMOS.BIN in maintenance mode, and then contact your Yaskawa representative about occurrence status (operating procedure).
		2	The set data for double-precision integer-type variable area is incorrect.	Software operation error occurred	(1)Reset the alarm, and then try again. (2)If the alarm occurs again, save the CMOS.BIN in maintenance mode, and then contact your Yaskawa representative about occurrence status (operating procedure).
		3	The set data for real type variable area is incorrect.	Software operation error occurred	(1)Reset the alarm, and then try again. (2)If the alarm occurs again, save the CMOS.BIN in maintenance mode, and then contact your Yaskawa representative about occurrence status (operating procedure).

Alarm Number	Alarm Name	Sub Code	Meaning	Cause	Remedy
		4	The set data for character-string type variable area is incorrect.	Software operation error occurred	(1)Reset the alarm, and then try again. (2)If the alarm occurs again, save the CMOS.BIN in maintenance mode, and then contact your Yaskawa representative about occurrence status (operating procedure).
		5	The set data for robot-axis position-type variable area is incorrect.	Software operation error occurred	(1)Reset the alarm, and then try again. (2)If the alarm occurs again, save the CMOS.BIN in maintenance mode, and then contact your Yaskawa representative about occurrence status (operating procedure).
		6	The set data for base-axis position-type variable (S1D parameter) area is incorrect.	Software operation error occurred	(1)Reset the alarm, and then try again. (2)If the alarm occurs again, save the CMOS.BIN in maintenance mode, and then contact your Yaskawa representative about occurrence status (operating procedure).
		7	The set data for station-axis position-type variable (S1D parameter) area is incorrect.	Software operation error occurred	(1)Reset the alarm, and then try again. (2)If the alarm occurs again, save the CMOS.BIN in maintenance mode, and then contact your Yaskawa representative about occurrence status (operating procedure).
4435	UNDEFINED LOCAL-VARIABLE	0	The byte type variable is not defined.	Setting error	(1)Check the following settings. -Set the number of local variables to be used in the job header.
		1	The integer type variable is not defined.	Setting error	(1)Check the following settings. -Set the number of local variables to be used in the job header.
		2	The double-precision integer-type variable is not defined.	Setting error	(1)Check the following settings. -Set the number of local variables to be used in the job header.
		3	The real-number type variable is not defined.	Setting error	(1)Check the following settings. -Set the number of local variables to be used in the job header.
		4	The character-string type variable is not defined.	Setting error	(1)Check the following settings. -Set the number of local variables to be used in the job header.
		5	The robot-axis position-type variable is not defined.	Setting error	(1)Check the following settings. -Set the number of local variables to be used in the job header.
		6	The base-axis position-type variable is not defined.	Setting error	(1)Check the following settings. -Set the number of local variables to be used in the job header.
		7	The station-axis position-type variable is not defined.	Setting error	(1)Check the following settings. -Set the number of local variables to be used in the job header.
4436	LESS THAN 3 STEPS (CIRCULAR)			Setting error	(1)Check the following settings. -Perform teaching so that circulation interpolation steps are continuous three points or more.

Alarm Number	Alarm Name	Sub Code	Meaning	Cause	Remedy
4438	UNDEFINED JOB			Setting error	(1)Check the following settings. ·Check if the CALL/JUMP destination job is registered. If the job is not registered, delete the JUMP instruction where an alarm occurred.
4439	UNDEFINED LABEL			Setting error	(1)Check the following settings. ·Check if the JUMP destination label is registered. If the label is not registered, delete the JUMP instruction where alarm occurred.
4440	UNDEFINED RETURN JOB			Setting error	(1)Check the following settings. ·If there is an illegal RET instruction in the start job, delete the RET instruction. ·Check if RET instruction is not executed under the condition that there is no job in the job call stack. In that case, execute it from
4441	LACK OF LOCAL-VARIABLE AREA			Setting error	(1)Check the following settings. ·Reduce the number of local variables to be used.
4444	UNSUCCESSFUL FINE POSITIONING		Sub Code: Bit specification of axis where error occurred	Effect of external force	(1)Check the following settings. ·Move the manipulator by the axis operation, etc. to remove the external force of axis where alarm occurred.
4445	DATA PRESET ERROR	1	The token for prereading processing could not be obtained.	Software operation error occurred	(1)Reset the alarm, and then try again. (2)If the alarm occurs again, save the CMOS.BIN in maintenance mode, and then contact your Yaskawa representative about occurrence status (operating procedure).
		2	The prereading processing has not been completed within the time, and the waiting time for completion exceeded the limit.	Software operation error occurred	(1)Reset the alarm, and then try again. (2)If the alarm occurs again, save the CMOS.BIN in maintenance mode, and then contact your Yaskawa representative about occurrence status (operating procedure).
		3	The prereading operation processing has not been completed within the time, and the waiting time for completion exceeded the limit.	Software operation error occurred	(1)Reset the alarm, and then try again. (2)If the alarm occurs again, save the CMOS.BIN in maintenance mode, and then contact your Yaskawa representative about occurrence status (operating procedure).
		4	An error occurred in prereading operation process.	Software operation error occurred	(1)Reset the alarm, and then try again. (2)If the alarm occurs again, save the CMOS.BIN in maintenance mode, and then contact your Yaskawa representative about occurrence status (operating procedure).
		5	A_BANK conversion has not been completed.	Software operation error occurred	(1)Reset the alarm, and then try again. (2)If the alarm occurs again, save the CMOS.BIN in maintenance mode, and then contact your Yaskawa representative about occurrence status (operating procedure).

Alarm Number	Alarm Name	Sub Code	Meaning	Cause	Remedy
		255	An exceptional error occurred in job execution process.	Software operation error occurred	(1)Reset the alarm, and then try again. (2)If the alarm occurs again, save the CMOS.BIN in maintenance mode, and then contact your Yaskawa representative about occurrence status (operating procedure).
4446	OVER VARIABLE LIMIT	0	The variable value exceeded the limit.	Setting error	(1)Check the following settings. · Check the settings for variable, and then correct the job to fall within the input range of the tag.
		1	The value for the binary (0/1) data type variable exceeded the limit.	Setting error	(1)Check the following settings. · Check the settings for variable, and then correct the job to fall within the input range of the tag.
		2	The value for the signed 1-byte data type variable is less than the minimum value.	Setting error	(1)Check the following settings. · Check the settings for variable, and then correct the job to fall within the input range of the tag.
		3	The value for the unsigned 1-byte data type variable is less than the minimum value.	Setting error	(1)Check the following settings. · Check the settings for variable, and then correct the job to fall within the input range of the tag.
		4	The value for the signed 2-byte data type variable is less than the minimum value.	Setting error	(1)Check the following settings. · Check the settings for variable, and then correct the job to fall within the input range of the tag.
		5	The value for the unsigned 2-byte data type variable is less than the minimum value.	Setting error	(1)Check the following settings. · Check the settings for variable, and then correct the job to fall within the input range of the tag.
		6	The value for the signed 4-byte data type variable is less than the minimum value.	Setting error	(1)Check the following settings. · Check the settings for variable, and then correct the job to fall within the input range of the tag.
		7	The value for the unsigned 4-byte data type variable is less than the minimum value.	Setting error	(1)Check the following settings. · Check the settings for variable, and then correct the job to fall within the input range of the tag.
		8	The value for the real-number 4-byte data type variable is less than the minimum value.	Setting error	(1)Check the following settings. · Check the settings for variable, and then correct the job to fall within the input range of the tag.
		14	The value for the character-string type variable is less than the minimum value.	Setting error	(1)Check the following settings. · Check the settings for variable, and then correct the job to fall within the input range of the tag.
		32770	The value for the signed 1-byte data type variable exceeded the maximum value.	Setting error	(1)Check the following settings. · Check the settings for variable, and then correct the job to fall within the input range of the tag.

Alarm Number	Alarm Name	Sub Code	Meaning	Cause	Remedy
		32771	The value for the unsigned 1-byte data type variable exceeded the maximum value.	Setting error	(1)Check the following settings. ·Check the settings for variable, and then correct the job to fall within the input range of the tag.
		32772	The value for the signed 2-byte data type variable exceeded the maximum value.	Setting error	(1)Check the following settings. ·Check the settings for variable, and then correct the job to fall within the input range of the tag.
		32773	The value for the unsigned 2-byte data type variable exceeded the maximum value.	Setting error	(1)Check the following settings. ·Check the settings for variable, and then correct the job to fall within the input range of the tag.
		32774	The value for the signed 4-byte data type variable exceeded the maximum value.	Setting error	(1)Check the following settings. ·Check the settings for variable, and then correct the job to fall within the input range of the tag.
		32775	The value for the unsigned 4-byte data type variable exceeded the maximum value.	Setting error	(1)Check the following settings. ·Check the settings for variable, and then correct the job to fall within the input range of the tag.
		32776	The value for the real-number 4-byte data type variable exceeded the maximum value.	Setting error	(1)Check the following settings. ·Check the settings for variable, and then correct the job to fall within the input range of the tag.
		32782	The value for the character-string type variable exceeded the maximum value.	Setting error	(1)Check the following settings. ·Check the settings for variable, and then correct the job to fall within the input range of the tag.
4447	DEFECTIVE TAUGHT POINT(CIRC)			Setting error	(1)Check the following settings. ·Check the settings for three teaching points so that circular interpolation steps do not lie in a straight line.
4449	UNMATCHED POSN VAR DATA TYPE			Setting error	(1)Check the following settings. ·Match the data type of position type variable.
4450	FILE NO. ERROR	1	An error occurred in tool file number check.	Setting error	(1)Check the following settings. ·Confirm that the specified tool file number is 0 to 63.
		2	An error occurred in user coordinate file number check.	Setting error	(1)Check the following settings. ·Confirm that the specified user coordinate file number is 1 to 63.
		3	An error occurred in calibration file number check between the manipulators.	Setting error	(1)Check the following settings. ·Confirm that the specified robot calibration file number is 1 to 32.
		4	An error occurred in tool calibration file number check.	Setting error	(1)Check the following settings. ·Confirm that the specified tool file number is 0 to 63.

Alarm Number	Alarm Name	Sub Code	Meaning	Cause	Remedy
		5	An error occurred in reference point number check.	Setting error	(1)Check the following settings. ·Confirm that the specified robot calibration file number is 1 to 8.
		9	An error occurred in conveyor characteristic file number check.	Setting error	(1)Check the following settings. ·Confirm that the specified conveyor condition file number is 1 to 6.
		10	An error occurred in press characteristic file number check.	Setting error	(1)Check the following settings. ·Confirm that the specified press characteristic file number is 0 to 3.
		12	An error occurred in conveyor calibration file number check.	Setting error	(1)Check the following settings. ·Confirm that the specified conveyor calibration file number is 1 to 6.
		13	An error occurred in argument number check.	Setting error	(1)Check the following settings. ·Confirm that the argument number is 1 to 16.
		15	An error occurred while checking the link (linear) servo float condition file number.	Setting error	(1)Check the following settings. ·Confirm that the link (linear) servo float condition file number is within the range of 1 to 8.
4451	UNDEFINED REFERENCE POINT		Sub Code: Reference point number in binary	Setting error	(1)Check the following settings. ·Set the reference point.
4452	STACK MORE THAN 10 (JOB CALL)			Setting error	(1)Check the following settings. ·Change the job configuration so that the number of nests for CALL instruction is twelve or less.
4453	OVER VARIABLE NO.		The variable number is out of range. Sub Code: The variable number which an attempt was made to use	Setting error	(1)Check the following settings. ·Correct the job using the variable number within the range.
4459	EXCESSIVE INSTRUCTION EQUATION			Setting error	(1)Check the following settings. ·Separate the operation expression, shorten the expression, and then check the settings for the job.
4460	ZERO DIVIDED OCCURRENCE			Setting error	(1)Check the following settings. ·Do not divide by zero.
4463	PARITY ERROR			Setting error	(1)Check the following settings. ·Check the settings for the parity data of the user I/O group.
4464	OVER BCD RANGE			Setting error	(1)Check the following settings. ·Correct the BCD data so that it is within the limit.
4465	OVER BINARY RANGE (PARITY CHECK)			Setting error	(1)Check the following settings. ·Correct the binary data so that it is within the limit.

Alarm Number	Alarm Name	Sub Code	Meaning	Cause	Remedy
4466	OFFLINE UNDEFINED COMMAND (ARITH)	0	An undefined command was issued to the offline position-data preparation section.	Software operation error occurred	(1)Reset the alarm, and then try again. (2)If the alarm occurs again, save the CMOS.BIN in maintenance mode, and then contact your Yaskawa representative about occurrence status (operating procedure).
4467	USER COORD STEP NOT ENOUGH			Setting error	(1)Check the following settings. ·Correct the JOB that the number of steps will be three or more.
4468	ROBOT CALIBRATION DATA ERROR	1	The calibration between manipulators cannot be executed for this model.	Setting error	(1)Check the following settings. ·Do not use a coordinated motion with this manipulator.
		2	The master group and the slave group are set to the same group.	Software operation error occurred	(1)Reset the alarm, and then try again. (2)If the alarm occurs again, save the CMOS.BIN in maintenance mode, and then contact your Yaskawa representative about occurrence status (operating procedure).
		3	Incorrect designation of the control group for master group	Software operation error occurred	(1)Reset the alarm, and then try again. (2)If the alarm occurs again, save the CMOS.BIN in maintenance mode, and then contact your Yaskawa representative about occurrence status (operating procedure).
		4	Incorrect designation of the control group for slave group	Software operation error occurred	(1)Reset the alarm, and then try again. (2)If the alarm occurs again, save the CMOS.BIN in maintenance mode, and then contact your Yaskawa representative about occurrence status (operating procedure).
		5	Incorrect designation of the occupation control group for calibration data	Software operation error occurred	(1)Reset the alarm, and then try again. (2)If the alarm occurs again, save the CMOS.BIN in maintenance mode, and then contact your Yaskawa representative about occurrence status (operating procedure).
		6	Incorrect designation of the enabling control group for calibration data	Software operation error occurred	(1)Reset the alarm, and then try again. (2)If the alarm occurs again, save the CMOS.BIN in maintenance mode, and then contact your Yaskawa representative about occurrence status (operating procedure).
		7	Among three points in the master-group's calibration data, two or three points are on the same point.	Setting error	(1)Check the following settings. ·Teach the data for calibration so that each point is different.
		8	Among three points in the slave-group's calibration data, two or three points are on the same point.	Setting error	(1)Check the following settings. ·Teach the data for calibration so that each point is different.

Alarm Number	Alarm Name	Sub Code	Meaning	Cause	Remedy
		9	The number of the teaching points for calibration data is insufficient.	Software operation error occurred	(1)Reset the alarm, and then try again. (2)If the alarm occurs again, save the CMOS.BIN in maintenance mode, and then contact your Yaskawa representative about occurrence status (operating procedure).
4469	ROBOT CALIBRATION FRAME ERROR	1	The calibration between manipulators cannot be executed for this model.	Setting error	(1)Check the following settings. ·The calibration function between manipulators cannot be used for this model.
		2	The master group and the slave group are set to the same group.	Setting error	(1)Check the following settings. ·Set the different groups for the master group and the slave group.
		3	Incorrect designation of the control group for master group	Software operation error occurred	(1)Reset the alarm, and then try again. (2)If the alarm occurs again, save the CMOS.BIN in maintenance mode, and then contact your Yaskawa representative about occurrence status (operating procedure).
		4	Incorrect designation of the control group for slave group	Software operation error occurred	(1)Reset the alarm, and then try again. (2)If the alarm occurs again, save the CMOS.BIN in maintenance mode, and then contact your Yaskawa representative about occurrence status (operating procedure).
		5	Calibration data setting error	Software operation error occurred	(1)Reset the alarm, and then try again. (2)If the alarm occurs again, save the CMOS.BIN in maintenance mode, and then contact your Yaskawa representative about occurrence status (operating procedure).
4470	ROBOT CARIB STEP NOT ENOUGH			Setting error	(1)Check the following settings. ·Check the settings for number of the job steps
4471	ROBOT CALIBRATION DATA ERROR	1	Incorrect number of teaching points for tool calibration	Software operation error occurred	(1)Reset the alarm, and then try again. (2)If the alarm occurs again, save the CMOS.BIN in maintenance mode, and then contact your Yaskawa representative about occurrence status (operating procedure).
		2	Incorrect designation of the occupation control group for calibration data	Software operation error occurred	(1)Reset the alarm, and then try again. (2)If the alarm occurs again, save the CMOS.BIN in maintenance mode, and then contact your Yaskawa representative about occurrence status (operating procedure).
		3	Incorrect designation of the enabling control group for calibration data	Software operation error occurred	(1)Reset the alarm, and then try again. (2)If the alarm occurs again, save the CMOS.BIN in maintenance mode, and then contact your Yaskawa representative about occurrence status (operating procedure).

Alarm Number	Alarm Name	Sub Code	Meaning	Cause	Remedy
		4	Incorrect designation of the control group for calibration data	Software operation error occurred	(1)Reset the alarm, and then try again. (2)If the alarm occurs again, save the CMOS.BIN in maintenance mode, and then contact your Yaskawa representative about occurrence status (operating procedure).
4473	ARITHMETIC ALARM RESET ERROR			Software operation error occurred	(1)Reset the alarm, and then try again. (2)If the alarm occurs again, save the CMOS.BIN in maintenance mode, and then contact your Yaskawa representative about occurrence status (operating procedure).
4474	WRONG CONTROL GROUP AXIS		Sub Code:The related control-group	Setting error	(1)Check the following settings. ·Make the setting in advance so that the control group of the CALL/JUMP designation job is included in that of the CALL/JUMP source job. ·Don't start the job which including control group under already operation by "PSTART.
4475	CANNOT EXECUTE JOB (NO ROBOT)			Setting error	(1)Check the following settings. ·Add the robot axis to the control-group of the job. ·A robot which executed SKILLSND is not defined as using MotoPlus sensor related API. Check the combination of the robot and MotoPlus application. If the alarm occurs again, save the CMOS.BIN in maintenance mode, and then contact your Yaskawa representative about occurrence status (operating procedure).
4476	CANNOT EDIT (EDIT LOCK JOB)	0	An attempt was made to change the tag data.	Setting error	(1)Check the following settings. ·Release the prohibition.
		1	An attempt was made to change the speed tag data.	Setting error	(1)Check the following settings. ·Release the prohibition.
		2	An attempt was made to change the board thickness tag data.	Setting error	(1)Check the following settings. ·Release the prohibition.
4477	SELECT ERROR (APPLICATION)		Sub Code: Application number	Setting error	(1)Check the following settings. ·Set the application to a specified robot by the application selection of maintenance mode.
4478	MM TASK NO RESPONSE (MotoPlus)			Software operation error occurred	(1)Turn the power OFF then back ON. (2)If the alarm occurs again, replace controller and load the MotoPlus application which was loaded to the previous controller. (3)If the alarm occurs again, save the CMOS.BIN in maintenance mode, and then contact your contact your Yaskawa representative about occurrence status (operating procedure).

Alarm Number	Alarm Name	Sub Code	Meaning	Cause	Remedy
4479	MotoPlus MM TASK WATCH DOG ERROR			Software operation error occurred	Check if there is high priority task of MotoPlus application running long time. Especially, check if there may be the process which waits for a special condition without executing mpTaskDelay in loop process. If such process exists, suitable remedy should be taken such as inserting mpTaskDelay, etc.
4480	SELECT ERROR (SENSOR 1)		Sub Code:Sensor number	Setting error	(1)Check the following settings. ·Select the option function for the specified robot in the option function selection of maintenance mode.
4485	WRONG SELECTION (SENSOR)			Software operation error occurred	(1)Reset the alarm, and then try again. (2)If the alarm occurs again, save the CMOS.BIN in maintenance mode, and then contact your Yaskawa representative about occurrence status (operating procedure).
4487	WRONG MECH PARAMETER FILE			Software operation error occurred	(1)Reset the alarm, and then try again. (2)If the alarm occurs again, save the CMOS.BIN in maintenance mode, and then contact your Yaskawa representative about occurrence status (operating procedure).
4490	DEFECTIVE TAUGHT POINT (ENDLESS)	1	After the Endless rotation completed, an attempt was made to execute an interpolation instruction such as MOVL and MOVC before executing an MRESET instruction.	Setting error	(1)Check the following settings. ·To perform an interpolation motion such as MOVL and MOVC after an Endless rotation, execute an MRESET instruction beforehand.
		2	The base axis is set as an Endless rotation axis. The Endless function cannot be used with the base axis.	Setting error	(1)Check the following settings. ·Check the parameter setting that designates the Endless rotation axis.
		3	An attempt was made to execute the Endless function although the endless axis was not designated.	Setting error	(1)Check the following settings. ·Check the parameter setting that designates the Endless rotation axis.
		4	The Endless axis exceeded the maximum pulse value (± 536870911).	Setting error	(1)Check the following settings. ·Set the rotation amount so that the Endless axis does not exceed the maximum pulse value.
4491	CORRECTIONAL DIRECTION ERROR	1	Control-group designation error for correcting-direction preparation	Software operation error occurred	(1)Reset the alarm, and then try again. (2)If the alarm occurs again, save the CMOS.BIN in maintenance mode, and then contact your Yaskawa representative about occurrence status (operating procedure).

Alarm Number	Alarm Name	Sub Code	Meaning	Cause	Remedy
		2	Designation error for the correcting-direction coordinates	Software operation error occurred	(1)Reset the alarm, and then try again. (2)If the alarm occurs again, save the CMOS.BIN in maintenance mode, and then contact your Yaskawa representative about occurrence status (operating procedure).
		3	When "any direction" is set for the correcting direction, the correction coordinates is not prepared.	Setting error	(1)Check the following settings. ·Check the settings for the correcting direction with the reference point (REFP).
		4	When "any direction" is set for the correcting direction, the reference points (REFP) are taught on the same point.	Setting error	(1)Check the following settings. ·Check the settings for the reference points (REFP) so that each point is different.
		5	Designation error for the coordinated motion control axis at the reference point	Setting error	(1)Check the following settings. ·Match the control group designation of the wall point and weaving execution.
4492	POSITION CORRECTION ERROR	1	Data unmatched between the correction amount data and the job data: The information about the control groups designated for the series of jobs, which is added to the correction amount data, does not include the valid control-group for the job.	Software operation error occurred	(1)Reset the alarm, and then try again. (2)If the alarm occurs again, save the CMOS.BIN in maintenance mode, and then contact your Yaskawa representative about occurrence status (operating procedure).
		2	Data unmatched between the correction amount data and the job data: The valid control-group information that is added to the correction amount data disagrees with the valid control-group for the job.	Software operation error occurred	(1)Reset the alarm, and then try again. (2)If the alarm occurs again, save the CMOS.BIN in maintenance mode, and then contact your Yaskawa representative about occurrence status (operating procedure).
4493	OVER TOOL FILE NO.			Software operation error occurred	(1)Reset the alarm, and then try again. (2)If the alarm occurs again, save the CMOS.BIN in maintenance mode, and then contact your Yaskawa representative about occurrence status (operating procedure).
4495	UNDEFINED ROBOT CALIBRATION		Sub Code: Control group which calibration is not completed	Setting error	(1)Check the following settings. ·Before using the coordinated motion, execute the calibration between manipulators.

Alarm Number	Alarm Name	Sub Code	Meaning	Cause	Remedy
4496	PARAMETER ERROR	1	The setting of the manipulator number is incorrect.	Setting error	(1)Reset the alarm, and then try again. (2)If the alarm occurs again, save the CMOS.BIN in maintenance mode, and then contact your Yaskawa representative about occurrence status (operating procedure).
		2	Zero is set for the resolution.	Setting error	(1)Reset the alarm, and then try again. (2)If the alarm occurs again, save the CMOS.BIN in maintenance mode, and then contact your Yaskawa representative about occurrence status (operating procedure).
		3	Zero is set in the feedback pulse parameter.	Setting error	(1)Reset the alarm, and then try again. (2)If the alarm occurs again, save the CMOS.BIN in maintenance mode, and then contact your Yaskawa representative about occurrence status (operating procedure).
		4	The setting of L-axis ball-screw data is incorrect.	Setting error	(1)Reset the alarm, and then try again. (2)If the alarm occurs again, save the CMOS.BIN in maintenance mode, and then contact your Yaskawa representative about occurrence status (operating procedure).
		5	The setting of U-axis ball-screw data is incorrect.	Setting error	(1)Reset the alarm, and then try again. (2)If the alarm occurs again, save the CMOS.BIN in maintenance mode, and then contact your Yaskawa representative about occurrence status (operating procedure).
		6	Zero or a negative value is set for MAXPPS.	Setting error	(1)Reset the alarm, and then try again. (2)If the alarm occurs again, save the CMOS.BIN in maintenance mode, and then contact your Yaskawa representative about occurrence status (operating procedure).
		7	Zero or a negative value is set for the maximum acceleration speed.	Setting error	(1)Reset the alarm, and then try again. (2)If the alarm occurs again, save the CMOS.BIN in maintenance mode, and then contact your Yaskawa representative about occurrence status (operating procedure).
		8	Zero or a negative value is set for the maximum deceleration speed.	Setting error	(1)Reset the alarm, and then try again. (2)If the alarm occurs again, save the CMOS.BIN in maintenance mode, and then contact your Yaskawa representative about occurrence status (operating procedure).
		9	Zero or a negative value is set for the play-mode servo averaging time.	Setting error	(1)Reset the alarm, and then try again. (2)If the alarm occurs again, save the CMOS.BIN in maintenance mode, and then contact your Yaskawa representative about occurrence status (operating procedure).

Alarm Number	Alarm Name	Sub Code	Meaning	Cause	Remedy
		10	The setting of the manipulator number is incorrect. An undefined type is designated.	Setting error	(1)Reset the alarm, and then try again. (2)If the alarm occurs again, save the CMOS.BIN in maintenance mode, and then contact your Yaskawa representative about occurrence status (operating procedure).
		11	The incorrect coordinate system is designated for the cubic interference. An undefined coordinate system is set.	Setting error	(1)Reset the alarm, and then try again. (2)If the alarm occurs again, save the CMOS.BIN in maintenance mode, and then contact your Yaskawa representative about occurrence status (operating procedure).
		12	The designation of the user coordinates number is incorrect. A number out of the setting range is set.	Setting error	(1)Reset the alarm, and then try again. (2)If the alarm occurs again, save the CMOS.BIN in maintenance mode, and then contact your Yaskawa representative about occurrence status (operating procedure).
		13	The reduction ratio ≤ 0 is output.	Setting error	(1)Reset the alarm, and then try again. (2)If the alarm occurs again, save the CMOS.BIN in maintenance mode, and then contact your Yaskawa representative about occurrence status (operating procedure).
		14	Zero or a negative value is set for the spring constant.	Setting error	(1)Reset the alarm, and then try again. (2)If the alarm occurs again, save the CMOS.BIN in maintenance mode, and then contact your Yaskawa representative about occurrence status (operating procedure).
		15	Zero or a negative value is set for the motor inertia.	Setting error	(1)Reset the alarm, and then try again. (2)If the alarm occurs again, save the CMOS.BIN in maintenance mode, and then contact your Yaskawa representative about occurrence status (operating procedure).
		16	Zero or a negative value is set for the speed calculation constant.	Setting error	(1)Reset the alarm, and then try again. (2)If the alarm occurs again, save the CMOS.BIN in maintenance mode, and then contact your Yaskawa representative about occurrence status (operating procedure).
		17	Dividing number setting error	Setting error	(1)Reset the alarm, and then try again. (2)If the alarm occurs again, save the CMOS.BIN in maintenance mode, and then contact your Yaskawa representative about occurrence status (operating procedure).
		18	The setting of allowable torque for the speed reducer is incorrect.	Setting error	(1)Reset the alarm, and then try again. (2)If the alarm occurs again, save the CMOS.BIN in maintenance mode, and then contact your Yaskawa representative about occurrence status (operating procedure).

Alarm Number	Alarm Name	Sub Code	Meaning	Cause	Remedy
		19	The setting of allowable torque for the motor is incorrect.	Setting error	(1)Reset the alarm, and then try again. (2)If the alarm occurs again, save the CMOS.BIN in maintenance mode, and then contact your Yaskawa representative about occurrence status (operating procedure).
		21	Zero or a negative value is set for the balancer.	Setting error	(1)Reset the alarm, and then try again. (2)If the alarm occurs again, save the CMOS.BIN in maintenance mode, and then contact your Yaskawa representative about occurrence status (operating procedure).
		22	The angle of hexagon set for the CUT instruction is out of the range "0 degree < angle < 60 degrees".	Setting error	(1)Reset the alarm, and then try again. (2)If the alarm occurs again, save the CMOS.BIN in maintenance mode, and then contact your Yaskawa representative about occurrence status (operating procedure).
		33	Zero is set for the response time constant.	Setting error	(1)Reset the alarm, and then try again. (2)If the alarm occurs again, save the CMOS.BIN in maintenance mode, and then contact your Yaskawa representative about occurrence status (operating procedure).
		35	Zero is set for the averaging time constant.	Setting error	(1)Reset the alarm, and then try again. (2)If the alarm occurs again, save the CMOS.BIN in maintenance mode, and then contact your Yaskawa representative about occurrence status (operating procedure).
		36	Torque limit ratio data error	Setting error	(1)Reset the alarm, and then try again. (2)If the alarm occurs again, save the CMOS.BIN in maintenance mode, and then contact your Yaskawa representative about occurrence status (operating procedure).
		39	The setting in the optimized acceleration/deceleration designation parameter is incorrect.	Setting error	(1)Reset the alarm, and then try again. (2)If the alarm occurs again, save the CMOS.BIN in maintenance mode, and then contact your Yaskawa representative about occurrence status (operating procedure).
		41	The dynamics-model calculation at the optimized acceleration/ deceleration is invalid.	Setting error	(1)Reset the alarm, and then try again. (2)If the alarm occurs again, save the CMOS.BIN in maintenance mode, and then contact your Yaskawa representative about occurrence status (operating procedure).
		42	Zero is set for the inertia of dynamics fixed model.	Setting error	(1)Reset the alarm, and then try again. (2)If the alarm occurs again, save the CMOS.BIN in maintenance mode, and then contact your Yaskawa representative about occurrence status (operating procedure).

Alarm Number	Alarm Name	Sub Code	Meaning	Cause	Remedy
		43	Designation error for dynamics-model calculation type	Setting error	(1)Reset the alarm, and then try again. (2)If the alarm occurs again, save the CMOS.BIN in maintenance mode, and then contact your Yaskawa representative about occurrence status (operating procedure).
		44	The optimized acceleration/ deceleration control of speed limit function is disabled.	Setting error	(1)Reset the alarm, and then try again. (2)If the alarm occurs again, save the CMOS.BIN in maintenance mode, and then contact your Yaskawa representative about occurrence status (operating procedure).
		45	The axis designation parameter for the speed limit function is not set.	Setting error	(1)Reset the alarm, and then try again. (2)If the alarm occurs again, save the CMOS.BIN in maintenance mode, and then contact your Yaskawa representative about occurrence status (operating procedure).
		46	The setting in the mode designation parameter for the speed limit function is incorrect.	Setting error	(1)Reset the alarm, and then try again. (2)If the alarm occurs again, save the CMOS.BIN in maintenance mode, and then contact your Yaskawa representative about occurrence status (operating procedure).
		47	Zero or negative value is set in the allowable braking torque parameter for the speed limit function.	Setting error	(1)Reset the alarm, and then try again. (2)If the alarm occurs again, save the CMOS.BIN in maintenance mode, and then contact your Yaskawa representative about occurrence status (operating procedure).
		48	Zero or a negative value is set in the speed adjustment ratio parameter for the speed limit function.	Setting error	(1)Reset the alarm, and then try again. (2)If the alarm occurs again, save the CMOS.BIN in maintenance mode, and then contact your Yaskawa representative about occurrence status (operating procedure).
		49	Zero or a negative value is set in the torque limit adjustment ratio parameter for the acceleration/ deceleration tuning.	Setting error	(1)Reset the alarm, and then try again. (2)If the alarm occurs again, save the CMOS.BIN in maintenance mode, and then contact your Yaskawa representative about occurrence status (operating procedure).
		50	Zero or a negative value is set in the parameter that sets the shortest acceleration/deceleration time for when the excessive torque is applied at the optimized acceleration/deceleration.	Setting error	(1)Reset the alarm, and then try again. (2)If the alarm occurs again, save the CMOS.BIN in maintenance mode, and then contact your Yaskawa representative about occurrence status (operating procedure).
		51	Zero is set for the dimension information "a3" for the SKR manipulator.	Setting error	(1)Reset the alarm, and then try again. (2)If the alarm occurs again, save the CMOS.BIN in maintenance mode, and then contact your Yaskawa representative about occurrence status (operating procedure).

Alarm Number	Alarm Name	Sub Code	Meaning	Cause	Remedy
		53	The parameter setting for the Cartesian manipulator X-axis data is incorrect.	Setting error	(1)Reset the alarm, and then try again. (2)If the alarm occurs again, save the CMOS.BIN in maintenance mode, and then contact your Yaskawa representative about occurrence status (operating procedure).
		54	The parameter setting for the Cartesian manipulator Y-axis data is incorrect.	Setting error	(1)Reset the alarm, and then try again. (2)If the alarm occurs again, save the CMOS.BIN in maintenance mode, and then contact your Yaskawa representative about occurrence status (operating procedure).
		56	Zero or a negative value is set in the FORMCUT maximum acceleration/deceleration time parameter.	Setting error	(1)Reset the alarm, and then try again. (2)If the alarm occurs again, save the CMOS.BIN in maintenance mode, and then contact your Yaskawa representative about occurrence status (operating procedure).
		85	The setting of wrist axis angle for tube-incorporated wrist type manipulators or three-roll wrist type manipulators is incorrect.	Setting error	(1)Reset the alarm, and then try again. (2)If the alarm occurs again, save the CMOS.BIN in maintenance mode, and then contact your Yaskawa representative about occurrence status (operating procedure).
		86	The special link JOG operation cannot be used with this manipulator.	Setting error	(1)Reset the alarm, and then try again. (2)If the alarm occurs again, save the CMOS.BIN in maintenance mode, and then contact your Yaskawa representative about occurrence status (operating procedure).
		87	The setting in the parameter for special angle limit check designation is incorrect.	Setting error	(1)Reset the alarm, and then try again. (2)If the alarm occurs again, save the CMOS.BIN in maintenance mode, and then contact your Yaskawa representative about occurrence status (operating procedure).
		92	A negative value is set in the roundness parameter for the path-priority control.	Setting error	(1)Reset the alarm, and then try again. (2)If the alarm occurs again, save the CMOS.BIN in maintenance mode, and then contact your Yaskawa representative about occurrence status (operating procedure).
		93	The link parameter for the cutting device is not set.	Setting error	(1)Reset the alarm, and then try again. (2)If the alarm occurs again, save the CMOS.BIN in maintenance mode, and then contact your Yaskawa representative about occurrence status (operating procedure).
		95	The real-time bending correction function is enabled for a control-group other than robot axis.	Setting error	(1)Reset the alarm, and then try again. (2)If the alarm occurs again, save the CMOS.BIN in maintenance mode, and then contact your Yaskawa representative about occurrence status (operating procedure).

Alarm Number	Alarm Name	Sub Code	Meaning	Cause	Remedy
		96	Zero is set for the dimension information "a2" for the Arc Cell Torch Arm type manipulators.	Setting error	(1)Reset the alarm, and then try again. (2)If the alarm occurs again, save the CMOS.BIN in maintenance mode, and then contact your Yaskawa representative about occurrence status (operating procedure).
		97	Zero is set for the deceleration ratio for double T-axis unit of the V-shaped double T-axis manipulator.	Setting error	(1)Reset the alarm, and then try again. (2)If the alarm occurs again, save the CMOS.BIN in maintenance mode, and then contact your Yaskawa representative about occurrence status (operating procedure).
		103	"α" is replaced with "0" in SKR1-5 type robot.	Setting error	(1)Reset the alarm, and then try again. (2)If the alarm occurs again, save the CMOS.BIN in maintenance mode, and then contact your Yaskawa representative about occurrence status (operating procedure).
		118	Wrong value in set for backlash correction function.	Setting error	(1)Reset the alarm, and then try again. (2)If the alarm occurs again, save the CMOS.BIN in maintenance mode, and then contact your Yaskawa representative about occurrence status (operating procedure).
		121	Incorrect parameter setting to inertia speed control function.	Setting error	(1)Reset the alarm, and then try again. (2)If the alarm occurs again, save the CMOS.BIN in maintenance mode, and then contact your Yaskawa representative about occurrence status (operating procedure).
		122	Incorrect acceleration/ deceleration time setting at tool mass acceleration/deceleration speed correction function.	Setting error	(1)Reset the alarm, and then try again. (2)If the alarm occurs again, save the CMOS.BIN in maintenance mode, and then contact your Yaskawa representative about occurrence status (operating procedure).
		123	Incorrect coefficient/item settings at tool mass acceleration/ deceleration speed correction function.	Setting error	(1)Reset the alarm, and then try again. (2)If the alarm occurs again, save the CMOS.BIN in maintenance mode, and then contact your Yaskawa representative about occurrence status (operating procedure).
		124	No tool mas as the minimum acceleration/deceleration time at tool mass acceleration/ deceleration speed correction function.	Setting error	(1)Reset the alarm, and then try again. (2)If the alarm occurs again, save the CMOS.BIN in maintenance mode, and then contact your Yaskawa representative about occurrence status (operating procedure).
		125	Incorrect speed setting at tool mass acceleration/deceleration speed correction function.	Setting error	(1)Reset the alarm, and then try again. (2)If the alarm occurs again, save the CMOS.BIN in maintenance mode, and then contact your Yaskawa representative about occurrence status (operating procedure).

Alarm Number	Alarm Name	Sub Code	Meaning	Cause	Remedy
		126	Incorrect coefficient/item settings at tool mass acceleration/ deceleration speed control function.	Setting error	(1)Reset the alarm, and then try again. (2)If the alarm occurs again, save the CMOS.BIN in maintenance mode, and then contact your Yaskawa representative about occurrence status (operating procedure).
		127	No tool mass as the maximum acceleration/deceleration time at tool mass acceleration/ deceleration speed control function.	Setting error	(1)Reset the alarm, and then try again. (2)If the alarm occurs again, save the CMOS.BIN in maintenance mode, and then contact your Yaskawa representative about occurrence status (operating procedure).
		129	An error in the standard arithmetical axis number setting for approximation model.	Setting error	(1)Reset the alarm, and then try again. (2)If the alarm occurs again, save the CMOS.BIN in maintenance mode, and then contact your Yaskawa representative about occurrence status (operating procedure).
		130	An error in the standard expanding point number setting for approximation model.	Setting error	(1)Reset the alarm, and then try again. (2)If the alarm occurs again, save the CMOS.BIN in maintenance mode, and then contact your Yaskawa representative about occurrence status (operating procedure).
		131	An error in the radius setting for approximation model.	Setting error	(1)Reset the alarm, and then try again. (2)If the alarm occurs again, save the CMOS.BIN in maintenance mode, and then contact your Yaskawa representative about occurrence status (operating procedure).
		132	setting error of arithmetical axis number in D-H method.	Setting error	(1)Reset the alarm, and then try again. (2)If the alarm occurs again, save the CMOS.BIN in maintenance mode, and then contact your Yaskawa representative about occurrence status (operating procedure).
		133	setting error of choosing no / wrong connection base arithmetical axis number in D-H method.	Setting error	(1)Reset the alarm, and then try again. (2)If the alarm occurs again, save the CMOS.BIN in maintenance mode, and then contact your Yaskawa representative about occurrence status (operating procedure).
		135	Base axis control point → Robot coordinate system offset setting prohibited	Setting error	(1)Reset the alarm, and then try again. (2)If the alarm occurs again, save the CMOS.BIN in maintenance mode, and then contact your Yaskawa representative about occurrence status (operating procedure).
		136	Pulse linked JOG function specification error	Setting error	(1)Reset the alarm, and then try again. (2)If the alarm occurs again, save the CMOS.BIN in maintenance mode, and then contact your Yaskawa representative about occurrence status (operating procedure).

Alarm Number	Alarm Name	Sub Code	Meaning	Cause	Remedy
		137	Dual drive control specification error	Setting error	(1)Reset the alarm, and then try again. (2)If the alarm occurs again, save the CMOS.BIN in maintenance mode, and then contact your Yaskawa representative about occurrence status (operating procedure).
		138	Notch filter supported acceleration and deceleration tuning: Notch filter function setting error	Setting error	(1)Reset the alarm, and then try again. (2)If the alarm occurs again, save the CMOS.BIN in maintenance mode, and then contact your Yaskawa representative about occurrence status (operating procedure).
		139	Notch filter supported acceleration and deceleration tuning: Notch filter (z2) setting error	Setting error	(1)Reset the alarm, and then try again. (2)If the alarm occurs again, save the CMOS.BIN in maintenance mode, and then contact your Yaskawa representative about occurrence status (operating procedure).
4497	DEFECTIVE TAUGHT POINT (CALIB)	1	Some of the teaching points for master-group are on the same point.	Setting error	(1)Check the following settings. ·Perform the teaching again so that the teaching points are different from one another.
		2	Some of the teaching points for slave-group are on the same point.	Setting error	(1)Check the following settings. ·Perform the teaching again so that the teaching points are different from one another.
		3	The 2nd-axis positions of C3, C4, and C5 of station axes are not the same.	Setting error	(1)Check the following settings. ·Perform the teaching again so that the 2ndaxis positions of C3, C4, and C5 of the station axes are the same.
		4	The 1st-axis positions of C1, C2, and C3 of station axes are not the same.	Setting error	(1)Check the following settings. ·Perform the teaching again so that the 1staxis positions of C1, C2, and C3 of station axes are the same.
		5	The 2nd-axis positions of C1, C2, and C3 of station axes are the same.	Setting error	(1)Check the following settings. ·Perform the teaching again so that the teaching positions are different from one another.
		6	The 1st-axis rotation direction of C3, C4, and C5 of station axes are not the same.	Setting error	(1)Check the following settings. ·Perform the teaching again so that the 1staxis rotation direction of C3, C4, and C5 of station axes are the same.
		7	The 1st-axis (elevation axis) positions of C1, C2, and C3 of station axes are not the same.	Setting error	(1)Check the following settings. ·Perform the teaching again so that the 1staxis (elevation axis) positions of C1, C2, and C3 of station axes are the same.
		8	The 1st-axis (elevation axis) positions of C3, C4, and C5 of station axes are not the same.	Setting error	(1)Check the following settings. ·Perform the teaching again so that the 1staxis (elevation axis) positions of C3, C4, and C5 of station axes are the same.

Alarm Number	Alarm Name	Sub Code	Meaning	Cause	Remedy
4498	CANNOT EXECUTE JOB (NO GRP AXIS)		An attempt was made to execute an instruction that could not be executed in a job without control group.	Setting error	(1)Check the following settings. ·Check the settings for the job instruction with control group.
4499	UNDEFINED POSITION VARIABLE		Sub Code: The variable number	Setting error	(1)Check the following settings. ·Check the settings for the position type variable.
4500	UNDEFINED USER FRAME		Sub Code: User coordinate number	Setting error	(1)Check the following settings. ·Check the settings for the user coordinate.
4501	OUT OF RANGE (PARALLEL PROCESS)		Sub Code: Task number	Software operation error occurred	(1)Reset the alarm, and then try again. (2)If the alarm occurs again, save the CMOS.BIN in maintenance mode, and then contact your Yaskawa representative about occurrence status (operating procedure).
4502	SL BOARD ON-LINE ERROR		The option board was detected not to operate normally at power ON.	Software operation error occurred	(1)Reset the alarm, and then try again. (2)If the alarm occurs again, save the CMOS.BIN in maintenance mode, and then contact your Yaskawa representative about occurrence status (operating procedure).
4507	REFP POS ERROR (SEARCH MOTION)			Setting error	(1)Check the following settings. ·Perform the teaching again so that the search start point and the motion target point are not the same. ·Increase the distance between the search start point and the motion target point.
4508	SPECIFIED ERROR (COORDINATE)	0	The specified coordinate system does not exist.	Setting error	(1)Check the following settings. ·Check the settings for the coordinate system which can be used.
		1	Designation error of the master tool coordinate system. This coordinate system cannot be used.	Setting error	(1)Check the following settings. ·Check the settings for the coordinate system which can be used.
		2	Designation error of the tool coordinate system. This coordinate system cannot be used.	Setting error	(1)Check the following settings. ·Check the settings for the coordinate system which can be used.
		3	Designation error of the direction of travel coordinate system (for a shared function). This coordinate system cannot be used.	Setting error	(1)Check the following settings. ·Check the settings for the coordinate system which can be used.

Alarm Number	Alarm Name	Sub Code	Meaning	Cause	Remedy
		4	Designation error of the any direction coordinate system (for a shared function). This coordinate system cannot be used.	Setting error	(1)Check the following settings. ·Check the settings for the coordinate system which can be used.
		6	Designation error of the conveyor coordinate system. This coordinate system cannot be used.	Setting error	(1)Check the following settings. ·Check the settings for the coordinate system which can be used.
		10	Designation error of the cylindrical coordinate system. This coordinate system cannot be used.	Setting error	(1)Check the following settings. ·Check the settings for the coordinate system which can be used.
		11	Designation error of the coordinate system for the external reference point. This coordinate system cannot be used.	Setting error	(1)Check the following settings. ·Check the settings for the coordinate system which can be used.
4509	MFRAME ERROR	1	The master-tool user coordinates could not be prepared.	Setting error	(1)Check the following settings. ·Execute the MFRAME instruction in coordinated job when you make the master tool user coordinate.
4510	CANNOT EXECUTE INSTRUCTION (SQRT)			Setting error	(1)Check the following settings. ·Check the job settings so that the second argument of SQRT instruction does not become negative.
4511	OUT OF RANGE (DROP-VALUE)		Sub Code: Control group exceeding the allowable value	Setting error	(1)Check the following settings. ·Confirm the load setting to the robot.
4512	TWOSTEPSSAMELINE (3 STEPS)			Setting error	(1)Check the following settings. ·Check the settings so that the teaching points are not aligned in a straight line.
4513	EXCESSIVE SEGMENT (SAFETY 1): LOW/HIGH		Sub Code: Control group and axis	Setting error	(1)Check the following settings. ·Reduce the speed of the step where the alarm occurred. ·Change the move instruction to joint interpolation (MOVJ). * Be careful to the peripheral interference since its movement changes.
4515	EXCESSIVE SEGMENT (SAFETY 2): LOW/HIGH		Sub Code: Control group and axis	Setting error	(1)Check the following settings. ·Reduce the speed of the step where the alarm occurred. ·Change the move instruction to joint interpolation (MOVJ). * Be careful to the peripheral interference since its movement changes.

Alarm Number	Alarm Name	Sub Code	Meaning	Cause	Remedy
4517	SEARCH MONITOR SET ERROR (SERVO)		Sub Code: The related control-group	Software operation error occurred	(1)Reset the alarm, and then try again. (2)If the alarm occurs again, save the CMOS.BIN in maintenance mode, and then contact your Yaskawa representative about occurrence status (operating procedure).
4518	SEARCH MON RELEASE ERROR (SERVO)		Sub Code: The related control-group	Software operation error occurred	(1)Reset the alarm, and then try again. (2)If the alarm occurs again, save the CMOS.BIN in maintenance mode, and then contact your Yaskawa representative about occurrence status (operating procedure).
4521	WRONG JOB TYPE		Sub Code 0000_0001: A robot job was started from the concurrent job at CALL/JUMP instruction execution. 0000_1001: A concurrent job was started from the robot job at CALL/JUMP instruction execution. 1000_0001: A system job was started from the robot job at CALL/JUMP instruction execution.	Setting error	(1)Check the following settings. ·Check the settings for the job to be started.
4522	TAG DATA CHANGE PROCESS ERROR	0	An attempt was made to change the contents of variable tag data.	Setting error	(1)Check the following settings. ·The variable tag cannot be changed. Correct the job so as not to use the variable tag.
		1	An attempt was made to change the tag data for the job prohibited from being edited.	Setting error	(1)Check the following settings. ·Release the prohibition.
		2	An error occurred at instruction read-in.	Software operation error occurred	(1)Reset the alarm, and then try again. (2)If the alarm occurs again, save the CMOS.BIN in maintenance mode, and then contact your Yaskawa representative about occurrence status (operating procedure).
		3	The tag is not registered.	Software operation error occurred	(1)Reset the alarm, and then try again. (2)If the alarm occurs again, save the CMOS.BIN in maintenance mode, and then contact your Yaskawa representative about occurrence status (operating procedure).
		4	The tag data was variable specification.	Setting error	(1)Check the following settings. ·The variable tag cannot be changed. Correct the job so as not to use the variable tag.

Alarm Number	Alarm Name	Sub Code	Meaning	Cause	Remedy
		5	The value which it was made to change exceeded the limit of tag data.	Setting error	(1)Check the following settings. ·Check the contents of changing data.
		7	An error occurred at tag data change.	Software operation error occurred	(1)Reset the alarm, and then try again. (2)If the alarm occurs again, save the CMOS.BIN in maintenance mode, and then contact your Yaskawa representative about occurrence status (operating procedure).
4524	CANNOT EXECUTE INST (COUCUR JOB)			Setting error	(1)Check the following settings. ·Delete an instruction that cannot be executed such as move instruction in the concurrent job.
4525	CANNOT EXECUTE SPECIFIED JOB	1	An interrupt job (user setting) is started up during the back operation.	Setting error	(1)Check the following settings. ·Check the job so that the interrupt job will not start-up during the back operation.
		2	An interrupt macro job is started up during the back operation.	Setting error	(1)Check the following settings. ·Check the job so that the interrupt macro job will not start-up during the back operation.
		3	An interrupt job (inside the system) is started up during the back operation.	Setting error	(1)Check the following settings. ·Check the job so that the interrupt job will not start-up during the back operation.
4527	UNDEFINED PORT NO.(AOUT)			Setting error	(1)Check the following settings. ·Check the settings for the specified analog output port number.
4528	SYNTAX ERROR	1	A syntax error was found in the IF sentence.	Software operation error occurred	(1)Reset the alarm, and then try again. (2)If the alarm occurs again, save the CMOS.BIN in maintenance mode, and then contact your Yaskawa representative about occurrence status (operating procedure).
4529	TWIN COORDINATED ERROR	1	A job without control group was started by SYNC instruction.	Setting error	(1)Check the following settings. ·Check the control group setting of the job to be started by SYNC.
		2	A job only with robot axes was started by SYNC instruction.	Setting error	(1)Check the following settings. ·Check the control group setting of the job to be started by SYNC.
		3	A job only with master control group axes was started by SYNC instruction.	Setting error	(1)Check the following settings. ·Check the control group setting of the job to be started by SYNC.
		4	At full synchronization, the completion timings of move instructions for the master and the slave disagreed.	Software operation error occurred	(1)Reset the alarm, and then try again. (2)If the alarm occurs again, save the CMOS.BIN in maintenance mode, and then contact your Yaskawa representative about occurrence status (operating procedure).

Alarm Number	Alarm Name	Sub Code	Meaning	Cause	Remedy
		5	At full synchronization, no operation request from the master was sent.	Software operation error occurred	(1)Reset the alarm, and then try again. (2)If the alarm occurs again, save the CMOS.BIN in maintenance mode, and then contact your Yaskawa representative about occurrence status (operating procedure).
		6	At full synchronization, the execution timings of move instructions for the master and the slave disagreed.	Software operation error occurred	(1)Reset the alarm, and then try again. (2)If the alarm occurs again, save the CMOS.BIN in maintenance mode, and then contact your Yaskawa representative about occurrence status (operating procedure).
		7	The twin synchronous ID number is incorrect.	Software operation error occurred	(1)Reset the alarm, and then try again. (2)If the alarm occurs again, save the CMOS.BIN in maintenance mode, and then contact your Yaskawa representative about occurrence status (operating procedure).
		8	An attempt was made to execute triple synchronization when specified Sub-master for the master was different.	Setting error	(1)Check the following settings. ·Match the system number specification of the master between the job to be started by SYNC.
4530	CONVEYOR TRACKING ERROR	1	The base axis specification is other than 1 or 2 for conveyor characteristic file.	Setting error	(1)Check the following settings. ·Set the base axis specification of conveyor characteristic file to either 0, 1, or 2.
		2	No robot axis in the job for robot axis tracking	Setting error	(1)Check the following settings. ·Correct the job setting so that the robot axis tracking is executed in the job where robot axis exists.
		3	No base axis in the job for base axis tracking	Setting error	(1)Check the following settings. ·Correct the job settings so that the base axis tracking is executed in the job where base axis exists.
		4	The conveyor board number and conveyor characteristic file number used are incorrect.	Setting error	(1)Check the following settings. ·Check the specification of conveyor condition file number for use.
		5	There was no conveyor start position data at prereading processing.	Software operation error occurred	(1)Reset the alarm, and then try again. (2)If the alarm occurs again, save the CMOS.BIN in maintenance mode, and then contact your Yaskawa representative about occurrence status (operating procedure).
		10	No base axis in the job for arc tracking	Setting error	(1)Check the following settings. ·Correct the job setting so that the arc tracking is executed in the job where robot axis exists.
4531	UNDEFINED CONVEYOR COND FILE		Sub Code: Conveyor characteristic file number	Setting error	(1)Check the following settings. ·Set "Use state" of conveyor characteristic file to "1: Use".

Alarm Number	Alarm Name	Sub Code	Meaning	Cause	Remedy
4532	CONVEYOR SPEED DOWN		Sub Code: Conveyor number	Setting error	(1)Check the following settings. ·Correct the "Conveyor Lowest Speed" set in the conveyor characteristic file.
4533	ARITHMETICERROR (CV TRACKING)	1	Designation error of the conveyor tracking control-group	Software operation error occurred	(1)Reset the alarm, and then try again. (2)If the alarm occurs again, save the CMOS.BIN in maintenance mode, and then contact your Yaskawa representative about occurrence status (operating procedure).
		2	Designation error of the user coordinates for the conveyor tracking	Software operation error occurred	(1)Reset the alarm, and then try again. (2)If the alarm occurs again, save the CMOS.BIN in maintenance mode, and then contact your Yaskawa representative about occurrence status (operating procedure).
		3	An attempt was made to use the conveyor tracking function with the slave manipulator at coordinate motion.	Setting error	(1)Check the following settings. ·The conveyor tracking cannot be executed to the slave manipulator of the coordinate system. Correct the job so that the conveyor tracking perform by the robot unit or without coordinated motion.
		4	Zero is set for the resolution for the turn-table synchronization.	Setting error	(1)Check the following settings. ·Check the settings for the resolution.
		5	Base axis tracking application error at the control whose conveyor coordinates are different.	Setting error	(1)Check the following settings. ·Set the tracking system to "robot axis tracking". ·Do not operate between different conveyors while it is set to "base-axis tracking".
		6	Turn table tracking application error at the control whose conveyor coordinates are different.	Setting error	(1)Check the following settings. ·Do not operate between different conveyors while it is set to turn table synchronization.
		7	Interpolation error of the control whose conveyor coordinates are different.	Setting error	(1)Check the following settings. ·Teach interpolation method to SYMOVL when operating between different conveyors.
4534	TORQUE INTERFERENCE			Setting error	(1)Check the following settings. ·Correctly set the weight information in the tool file. (Are the weight: W and the number set to the load value of either Xg, Yg or Zg) ·Reduce the speed in the step where the alarm occurred.
4535	TARGET VARIABLE TYPE UNMATCHED	0	An attempt was made to obtain the byte type system variable by the other type variable.	Setting error	(1)Check the following settings. ·Obtain as the byte type variable.
		1	An attempt was made to obtain the integer type system variable by the other type variable.	Setting error	(1)Check the following settings. ·Obtain as the integer type variable.

Alarm Number	Alarm Name	Sub Code	Meaning	Cause	Remedy
		2	An attempt was made to obtain the double-precision integer-type system variable by the other type variable.	Setting error	(1)Check the following settings. ·Obtain as the double-precision integer-type variable.
		3	An attempt was made to obtain the real-number type system variable by the other type variable.	Setting error	(1)Check the following settings. ·Obtain as the real-number type variable.
		4	An attempt was made to obtain the character-string type system variable by the other type variable.	Setting error	(1)Check the following settings. ·Obtain as the character-string type variable.
4538	ROBOT AXIS TRACKING INVALID	0	"SYMOVJ" instruction is executed at robot-axis tracking.	Setting error	(1)Check the following settings. ·Do not use "SYMOVJ" instruction in robot axis tracking.
4539	CORNER R CONTROL ERROR	1	The Corner-R motion cannot be used for coordinated motion.	Setting error	(1)Check the following settings. ·Do not use the Corner-R motion for coordinated motion.
		2	An attempt was made to execute the Corner-R motion for the same point.	Setting error	(1)Check the following settings. ·Check the settings for the teaching so that the start step and end step are not on the same point.
		3	The Corner-R zone is taught on a straight line.	Setting error	(1)Check the following settings. ·Check the settings for teaching so that the Corner-R zone is not on a strait line.
		4	The start position or end position for the Corner-R motion could not be calculated inside the start zone or the end zone.	Setting error	(1)Check the following settings. ·Make the setting for the Corner-R radius small. ·Make the moving amount of the Corner-R start step long. ·Make the moving amount of the Corner-R start end long.
		5	The Corner-R motion cannot be used for coordinated motion (with master manipulators).	Setting error	(1)Check the following settings. ·Do not use the Corner-R motion for master manipulators at coordinated motion.
		6	The Corner-R motion cannot be used for MOVJ, MOV, and EIMOVJ instructions.	Setting error	(1)Check the following settings. ·Use a MOVL instruction when using the Corner-R motion.
		8	Different tool numbers are set in a Corner-R zone (for the Corner-R middle step and end step).	Setting error	(1)Check the following settings. ·Use the same tool number in a Corner-R zone.
		17	The Corner-R motion is disabled during conveyor tracking.	Setting error	(1)Check the following settings. ·Do not perform the conveyor tracking when using the Corner-R motion.

Alarm Number	Alarm Name	Sub Code	Meaning	Cause	Remedy
		18	Arithmetic error occurred when calculating the acceleration and deceleration time for the Corner-R operation	Setting error	(1)Check the following settings. ·Do not perform the conveyor tracking when using the Corner-R motion.
		20	The Corner-R motion is disabled to start during continuous motion.	Setting error	(1)Check the following settings. ·Make the setting for the Corner-R radius small. ·set Timer or PL=0 to a previous line.
4540	JOB QUE EMPTY ERROR			Setting error	(1)Check the following settings. ·Use "CALL QUE" under the condition that the job data is set to the job queue.
4541	INVALID INPUT STRING (VAL)	1	There was no character string representing a constant in character string to be extracted at VAL instruction execution.	Setting error	(1)Check the following settings. ·Check the settings for the data of the character string to be extracted.
4542	MRESET ERROR	1	An MRESET instruction was executed while no endless axis was designated.	Setting error	(1)Check the following settings. ·Set the endless axis.
4543	STACK LESS THAN 0 (JOB CALL)		At job return, an attempt was made to fetch a data from an empty job call stack or to stack a data in the job call stack that is full.	Software operation error occurred	(1)Reset the alarm, and then try again. (2)If the alarm occurs again, save the CMOS.BIN in maintenance mode, and then contact your Yaskawa representative about occurrence status (operating procedure).
4544	MID\$ INST ERROR	1	The first character of character string to be extracted is null at MID\$ instruction execution.	Setting error	(1)Check the following settings. ·Check the settings for the data of the character string to be extracted.
		2	The extraction start position exceeds the character string length at MID\$ instruction execution.	Setting error	(1)Check the following settings. ·Check the settings for the data of the character string to be extracted.
4546	CANNOT EXECUTE SYSTEM JOB		Sub Code: System number	Software operation error occurred	(1)Reset the alarm, and then try again. (2)If the alarm occurs again, save the CMOS.BIN in maintenance mode, and then contact your Yaskawa representative about occurrence status (operating procedure).
4547	PRIMITIVE ERROR		Sub Code: Error code	Software operation error occurred	(1)Reset the alarm, and then try again. (2)If the alarm occurs again, save the CMOS.BIN in maintenance mode, and then contact your Yaskawa representative about occurrence status (operating procedure).

Alarm Number	Alarm Name	Sub Code	Meaning	Cause	Remedy
4548	CANNOT OPERATE SPECIFIED EVENT		Sub Code: System number	Software operation error occurred	(1)Reset the alarm, and then try again. (2)If the alarm occurs again, save the CMOS.BIN in maintenance mode, and then contact your Yaskawa representative about occurrence status (operating procedure).
4549	NOT EXECUTION OF INIEVNT		Sub Code: System number	Setting error	(1)Check the following settings. ·Execute an INIEVNT instruction before executing an event related instruction.
4550	CANNOT EXECUTE INST (USER JOB)		Sub Code: System number	Setting error	(1)Check the following settings. ·This instruction cannot be executed in the system job. Correct the job so that the instruction is executed in the user job.
4565	SOFTWARE UNMATCH	1	The multi-layer welding function is not used.	Software operation error occurred	(1)Reset the alarm, and then try again. (2)If the alarm occurs again, save the CMOS.BIN in maintenance mode, and then contact your Yaskawa representative about occurrence status (operating procedure).
		3	The TURBO function is not used.	Software operation error occurred	(1)Reset the alarm, and then try again. (2)If the alarm occurs again, save the CMOS.BIN in maintenance mode, and then contact your Yaskawa representative about occurrence status (operating procedure).
		5	The conveyor/press synchronization function is not used.	Software operation error occurred	(1)Reset the alarm, and then try again. (2)If the alarm occurs again, save the CMOS.BIN in maintenance mode, and then contact your Yaskawa representative about occurrence status (operating procedure).
		6	The shared motion function is not used.	Software operation error occurred	(1)Reset the alarm, and then try again. (2)If the alarm occurs again, save the CMOS.BIN in maintenance mode, and then contact your Yaskawa representative about occurrence status (operating procedure).
		7	The layer motion function is not used.	Software operation error occurred	(1)Reset the alarm, and then try again. (2)If the alarm occurs again, save the CMOS.BIN in maintenance mode, and then contact your Yaskawa representative about occurrence status (operating procedure).
		8	The general sensor function is not used.	Software operation error occurred	(1)Reset the alarm, and then try again. (2)If the alarm occurs again, save the CMOS.BIN in maintenance mode, and then contact your Yaskawa representative about occurrence status (operating procedure).
		9	The servo float function is not used.	Software operation error occurred	(1)Reset the alarm, and then try again. (2)If the alarm occurs again, save the CMOS.BIN in maintenance mode, and then contact your Yaskawa representative about occurrence status (operating procedure).

Alarm Number	Alarm Name	Sub Code	Meaning	Cause	Remedy
		10	The laser cutting function (with small circle cutter) is not used.	Software operation error occurred	(1)Reset the alarm, and then try again. (2)If the alarm occurs again, save the CMOS.BIN in maintenance mode, and then contact your Yaskawa representative about occurrence status (operating procedure).
		11	The motor gun function (for spot welding application) is not used.	Software operation error occurred	(1)Reset the alarm, and then try again. (2)If the alarm occurs again, save the CMOS.BIN in maintenance mode, and then contact your Yaskawa representative about occurrence status (operating procedure).
		12	The speed control function (VCON/VCOF) is not used.	Software operation error occurred	(1)Reset the alarm, and then try again. (2)If the alarm occurs again, save the CMOS.BIN in maintenance mode, and then contact your Yaskawa representative about occurrence status (operating procedure).
		14	The laser cutting function (for form cutting operation) is not used.	Software operation error occurred	(1)Reset the alarm, and then try again. (2)If the alarm occurs again, save the CMOS.BIN in maintenance mode, and then contact your Yaskawa representative about occurrence status (operating procedure).
		15	The series communication function between the systems (PSEND/PRECV) is not used.	Software operation error occurred	(1)Reset the alarm, and then try again. (2)If the alarm occurs again, save the CMOS.BIN in maintenance mode, and then contact your Yaskawa representative about occurrence status (operating procedure).
		16	The motion extension function is not used.	Software operation error occurred	(1)Reset the alarm, and then try again. (2)If the alarm occurs again, save the CMOS.BIN in maintenance mode, and then contact your Yaskawa representative about occurrence status (operating procedure).
		17	The bending function is not used.	Software operation error occurred	(1)Reset the alarm, and then try again. (2)If the alarm occurs again, save the CMOS.BIN in maintenance mode, and then contact your Yaskawa representative about occurrence status (operating procedure).
		18	The ME-NET function is not used.	Software operation error occurred	(1)Reset the alarm, and then try again. (2)If the alarm occurs again, save the CMOS.BIN in maintenance mode, and then contact your Yaskawa representative about occurrence status (operating procedure).
		19	The MEMO-PLAY function is not used.	Software operation error occurred	(1)Reset the alarm, and then try again. (2)If the alarm occurs again, save the CMOS.BIN in maintenance mode, and then contact your Yaskawa representative about occurrence status (operating procedure).

Alarm Number	Alarm Name	Sub Code	Meaning	Cause	Remedy
		20	The 3D-SHIFT function is not used.	Software operation error occurred	(1)Reset the alarm, and then try again. (2)If the alarm occurs again, save the CMOS.BIN in maintenance mode, and then contact your Yaskawa representative about occurrence status (operating procedure).
		255	An attempt was made to execute an undefined instruction.	Software operation error occurred	(1)Reset the alarm, and then try again. (2)If the alarm occurs again, save the CMOS.BIN in maintenance mode, and then contact your Yaskawa representative about occurrence status (operating procedure).
4566	USER FRAME MAKING ERROR	1	The teaching points are incorrect.	Software operation error occurred	(1)Reset the alarm, and then try again. (2)If the alarm occurs again, save the CMOS.BIN in maintenance mode, and then contact your Yaskawa representative about occurrence status (operating procedure).
		2	The teaching points for user-coordinate turning are incorrect.	Setting error	(1)Check the following settings. ·Among three taught points in the teaching position. Teach the three points again so that they do not lie in the straight line.
		3	The robot axis is not specified for the control group of the job to prepare the user coordinates.	Software operation error occurred	(1)Reset the alarm, and then try again. (2)If the alarm occurs again, save the CMOS.BIN in maintenance mode, and then contact your Yaskawa representative about occurrence status (operating procedure).
		5	Position data error	Software operation error occurred	(1)Reset the alarm, and then try again. (2)If the alarm occurs again, save the CMOS.BIN in maintenance mode, and then contact your Yaskawa representative about occurrence status (operating procedure).
		6	Setting error of the slave group for user coordinate conversion	Software operation error occurred	(1)Reset the alarm, and then try again. (2)If the alarm occurs again, save the CMOS.BIN in maintenance mode, and then contact your Yaskawa representative about occurrence status (operating procedure).
4567	CANNOT MONITOR DISTANCE			Setting error	(1)Check the following settings. ·Change the interpolation instruction to MOVL/MOVC. ·Change the setting so that the arc retry or restart operation does not perform.
4568	UNDEFINED PRESS COND DATA FILE		Sub Code: Press characteristic file number	Setting error	(1)Check the following settings. ·Set the status of press characteristic file to be used in the job to "Used State".
4569	UNDEFINED PRESS RESOLUTION DATA		Sub Code: Press characteristic file number	Setting error	(1)Check the following settings. ·Set the press resolution data to be used in the job.
4571	SERVO FLOAT MODE RELEASE ERROR			Software operation error occurred	(1)Reset the alarm, and then try again. (2)If the alarm occurs again, save the CMOS.BIN in maintenance mode, and then contact your Yaskawa representative about occurrence status (operating procedure).

Alarm Number	Alarm Name	Sub Code	Meaning	Cause	Remedy
4579	ANTICIPATION CONTROL ERROR	1	No availability in anticipation control	Setting error	(1)Check the following settings. ·Maximum simultaneous execution number of anticipation control is five. Correct the settings for the job so that it is within five.
		2	The anticipation data exceeded the maximum length.	Software operation error occurred	(1)Reset the alarm, and then try again. (2)If the alarm occurs again, save the CMOS.BIN in maintenance mode, and then contact your Yaskawa representative about occurrence status (operating procedure).
4581	DEFECTIVE ANTICIPATION OT FILE	1	Incorrect setting of OT output number for anticipation output file	Setting error	(1)Check the following settings. ·Check the setting value of OT output number.
		2	Incorrect setting of OG output number for anticipation output file	Setting error	(1)Check the following settings. ·Check the setting value of OG output number.
4585	SERVO PG ON ERROR			Connection failure	(1)Reset the alarm, and then try again. (2)If the alarm occurs again, check the connection and inserting state of the following cables and connectors. ·Each axes encoder cable
4591	SPEED CTRL MODE SET ERROR (SERVO)			Software operation error occurred	(1)Reset the alarm, and then try again. (2)If the alarm occurs again, save the CMOS.BIN in maintenance mode, and then contact your Yaskawa representative about occurrence status (operating procedure).
4592	SPEED CTRL MODE CANCEL ERROR(SV)			Software operation error occurred	(1)Reset the alarm, and then try again. (2)If the alarm occurs again, save the CMOS.BIN in maintenance mode, and then contact your Yaskawa representative about occurrence status (operating procedure).
4595	CAN'T DO FIXED FORM CUT MOTION	1	The setting for radius is incorrect. (1) For a circle, it is incorrectly set as: radius ≤ 0 , or radius $<$ minimum radius value, or radius $>$ maximum radius value. (2) For an ellipse, it is incorrectly set as: radius ≤ 0 or radius $<$ minimum radius value/2, or radius $>$ (maximum radius/2 - width/2) value.	Setting error	(1)Check the following settings. ·Setting of the radius data

Alarm Number	Alarm Name	Sub Code	Meaning	Cause	Remedy
		2	The setting for width is incorrect. (1) For a rectangle, it is incorrectly set as: width < 1.0, width > sqrt (maximum diameter ² - height ²), or width > maximum diameter. (2) It is incorrectly set as: width < 0, width > maximum diameter -2 * radius.	Setting error	(1)Check the following settings. ·Setting of the width data
		3	The setting for height is incorrect. (1) For a rectangle, it is incorrectly set as: height > maximum diameter, height < minimum diameter/2, or height > sqrt (maximum diameter ² - width ²).	Setting error	(1)Check the following settings. ·Setting of the height data
		4	The setting for the corner radius is incorrect. (1) For a rectangle, it is incorrectly set as: corner radius > width/2 or corner radius > height/2.	Setting error	(1)Check the following settings. ·Setting of the corner radius
		5	The setting for overlap is incorrect. (1) For a rectangle, it is incorrectly set as overlap > width/2. (2) For a circle, it is incorrectly set as overlap > ABS (2π * radius). (3) For an ellipse, it is incorrectly set as overlap > π * radius +ABS (width/2).	Setting error	(1)Check the following settings. ·Setting of the overlap data
		6	The setting for the cutting speed is incorrect. It is set as the cutting speed > maximum linear speed.	Setting error	(1)Check the following settings. ·Setting of the cutting speed
		7	Coordinated motion cannot be used with the Form Cutting motion.	Setting error	(1)Check the following settings. ·Do not use the coordinated motion.
		8	Zero or a negative value is set in the minimum diameter parameter (S1CxG063) for the Form Cutting motion.	Setting error	(1)Check the following settings. ·The setting of the minimum diameter parameter (S1CxG063) for the Form Cutting motion.

Alarm Number	Alarm Name	Sub Code	Meaning	Cause	Remedy
		9	Zero or a negative value is set in the maximum diameter parameter (S1CxG064) for the Form Cutting motion.	Setting error	(1)Check the following settings. ·The setting of the maximum diameter parameter (S1CxG064) for the Form Cutting motion.
		10	Although "PLACEMENT" or "AUTO" is set for the start point designation on the FORM CUT SETTING window, the FORMAPR instruction was not executed.	Setting error	(1)Check the following settings. ·Execute the FORMAPR instruction.
		11	The Cut file setting of the FORMAPR instruction is different from that of the FORMCUT instruction.	Setting error	(1)Check the following settings. ·The Cut file settings of FORMAPR and FORMCUT instructions must be same.
4596	FORMCUT ERROR	1	An attempt was made to re-execute the FORMCUT instruction after interrupting it.	Execute condition failure	(1)Check the following settings. ·Re-execute the move instruction executed before the FORMCUT instruction, and then execute the FORMCUT instruction again.
4597	OFFLINE POSITION DATA CONVERT ERROR	1	Incorrect information of reference position data for offline position data conversion	Software operation error occurred	(1)Reset the alarm, and then try again. (2)If the alarm occurs again, save the CMOS.BIN in maintenance mode, and then contact your Yaskawa representative about occurrence status (operating procedure).
		3	Incorrect reference-point data for offline position data conversion	Software operation error occurred	(1)Reset the alarm, and then try again. (2)If the alarm occurs again, save the CMOS.BIN in maintenance mode, and then contact your Yaskawa representative about occurrence status (operating procedure).
		4	The standard position data for offline position data conversion could not correctly be calculated.	Setting error	(1)Check the following settings. ·The variable position may be out of the robot motion range. Check if the variable position is within the robot motion range.
		5	Incorrect pulse incremental value for offline position data conversion	Software operation error occurred	(1)Reset the alarm, and then try again. (2)If the alarm occurs again, save the CMOS.BIN in maintenance mode, and then contact your Yaskawa representative about occurrence status (operating procedure).
		6	The position data could not correctly be added by the pulse incremental value at the offline position data conversion.	Software operation error occurred	(1)Reset the alarm, and then try again. (2)If the alarm occurs again, save the CMOS.BIN in maintenance mode, and then contact your Yaskawa representative about occurrence status (operating procedure).

Alarm Number	Alarm Name	Sub Code	Meaning	Cause	Remedy
		7	Incorrect Cartesian incremental value for offline position data conversion	Software operation error occurred	(1)Reset the alarm, and then try again. (2)If the alarm occurs again, save the CMOS.BIN in maintenance mode, and then contact your Yaskawa representative about occurrence status (operating procedure).
		8	The position data could not correctly be added by the Cartesian incremental value at the offline position data conversion.	Setting error	(1)Check the following settings. ·The variable position may be out of the robot motion range. Check if the variable position is within the robot motion range.
		9	The position conversion could not be done in the designated coordinate system at the offline position data conversion.	Software operation error occurred	(1)Reset the alarm, and then try again. (2)If the alarm occurs again, save the CMOS.BIN in maintenance mode, and then contact your Yaskawa representative about occurrence status (operating procedure).
		10	Incorrect incremental value of angle for offline position data conversion	Software operation error occurred	(1)Reset the alarm, and then try again. (2)If the alarm occurs again, save the CMOS.BIN in maintenance mode, and then contact your Yaskawa representative about occurrence status (operating procedure).
		11	The position data could not correctly be added by the incremental value of angle at the offline position data conversion.	Software operation error occurred	(1)Reset the alarm, and then try again. (2)If the alarm occurs again, save the CMOS.BIN in maintenance mode, and then contact your Yaskawa representative about occurrence status (operating procedure).
		14	The reverse shift value could not correctly be calculated at the offline position data conversion.	Software operation error occurred	(1)Reset the alarm, and then try again. (2)If the alarm occurs again, save the CMOS.BIN in maintenance mode, and then contact your Yaskawa representative about occurrence status (operating procedure).
		15	The reverse shift value could not correctly be calculated at the offline position data conversion.	Software operation error occurred	(1)Reset the alarm, and then try again. (2)If the alarm occurs again, save the CMOS.BIN in maintenance mode, and then contact your Yaskawa representative about occurrence status (operating procedure).
		17	The shift value could not correctly be added at the offline position data conversion.	Software operation error occurred	(1)Reset the alarm, and then try again. (2)If the alarm occurs again, save the CMOS.BIN in maintenance mode, and then contact your Yaskawa representative about occurrence status (operating procedure).
		19	The positions for the mirror shift function could not correctly be calculated at the offline position data conversion.	Software operation error occurred	(1)Reset the alarm, and then try again. (2)If the alarm occurs again, save the CMOS.BIN in maintenance mode, and then contact your Yaskawa representative about occurrence status (operating procedure).

Alarm Number	Alarm Name	Sub Code	Meaning	Cause	Remedy
		20	The positions could not correctly be converted for the mirror shift function at the offline position data conversion.	Setting error	(1)Check the following settings. ·The variable position may be out of the robot motion range. Check if the variable position is within the robot motion range.
		22	Incorrect designation of coordinates for a new mirror-shift conversion function at the offline position data conversion	Software operation error occurred	(1)Reset the alarm, and then try again. (2)If the alarm occurs again, save the CMOS.BIN in maintenance mode, and then contact your Yaskawa representative about occurrence status (operating procedure).
4599	SERVO COMMAND ERROR		An attempt was made to issue the command while the servo control processing has not completed. Sub Code: Servo CPU bit number	Software operation error occurred	(1)Reset the alarm, and then try again. (2)If the alarm occurs again, save the CMOS.BIN in maintenance mode, and then contact your Yaskawa representative about occurrence status (operating procedure).
4604	SPECIFIED ERROR (ABSO RECOVER AXIS)			Setting error	(1)Check the following settings. ·Registration for the home position correction data.
4605	SETTOOL ERROR	1	The difference between the current tool constant and a new set value exceeded the allowable range (parameter set value).	Setting error	(1)Check the following settings. ·Correct the job so that the setting value of tag is allowable value. ·Set the allowance amount of the tool data automatic setting function maximum deviation (S3C1192) to large value.
4606	LACK OF GLOBAL VARIABLE AREA			Software operation error occurred	(1)Reset the alarm, and then try again. (2)If the alarm occurs again, save the CMOS.BIN in maintenance mode, and then contact your Yaskawa representative about occurrence status (operating procedure).
4607	WRONG EXECUTION OF MACRO INST	1	The execution macro job is not set.	Setting error	(1)Check the following settings. ·Check the settings for execution macro job.
		2	The interrupt macro job is not set.	Setting error	(1)Check the following settings. ·Check the settings for interrupt macro job.
		3	An attempt was made to start the job that could not be started by the macro instruction.	Setting error	(1)Check the following settings. ·Check the settings for macro job.
		5	An error occurred in the operation process of job call stack when the execution of macro instruction was cancelled.	Software operation error occurred	(1)Reset the alarm, and then try again. (2)If the alarm occurs again, save the CMOS.BIN in maintenance mode, and then contact your Yaskawa representative about occurrence status (operating procedure).
		6	Incorrect macro number	Software operation error occurred	(1)Reset the alarm, and then try again. (2)If the alarm occurs again, save the CMOS.BIN in maintenance mode, and then contact your Yaskawa representative about occurrence status (operating procedure).

Alarm Number	Alarm Name	Sub Code	Meaning	Cause	Remedy
4608	WRONG EXECUTION OF GETARG INST	1	The job argument is not set.	Setting error	(1)Check the following settings. ·Check the settings for jobs.
		2	No number of the specified job argument	Setting error	(1)Check the following settings. ·Check the settings for jobs.
		3	The data types of job argument disagreed.	Setting error	(1)Check the following settings. ·Check the settings for jobs.
4611	OVER OPTON INST EXECUTION LIMIT			Setting error	(1)Check the following settings. ·Check the settings for the OPTON instruction. OPTON instruction can use only the function to five simultaneously.
4612	TSYNC ERROR		Sub code: the number of synchronizations of the first executed TSYNC	Setting error	(1)Check the following settings. ·Check the settings for the number of synchronizations of the TSYNC instruction.
4615	I/O AXIS OPERATING		An attempt was made to command a job whose control group was in I/O axis motion.	Setting error	(1)Check the following settings. ·Does not the I/O axis motion executed for the control group that executing the job? ·Does not the job executed for the control group that operating by the I/O axis motion? The control group where the I/O axis is operating
4619	UNDEFINED JOB ENTRY TABLE		Sub Code: Designated registration number	Setting error	(1)Check the following settings. ·Check the settings for the job registration table.
4620	ARM (TOOL) INTERFERENCE		Sub Code: Interfering control group and axis & interfered control group and axis.	Setting error	(1)Check the following settings. ·Modify the teaching so that the robots indicated by the sub code would not interfere each other. ·Confirm the tool mode (tool interference file) of the robots indicated by the sub code would not interfere each other. ·Confirm the calibration between the robots is set correctly.

Alarm Number	Alarm Name	Sub Code	Meaning	Cause	Remedy
4622	SELF-INTERFERENCE		Sub Code:Control group & interfering axis number & interfered axis number.	Setting error	(1)Check the following settings. ·Modify the teaching so that the robots indicated by the sub code would not interfere each other ·Confirm the tool mode (tool interference file) of the robots indicated by the sub code would not interfere each other (2) If the manipulator is stopped near the interference area by servo OFF, it may interfere with the interference area. In this case, execute the following operations to disable the self interference check and move each part out of the interference area. - Change the mode to "TEACH" - To display LIMIT RELEASE window, select the main menu [ROBOT] and then [LIMIT RELEASE] - Change the setting for SELF INTERFERENCE RELEASE from "INVALID" to "VALID" by [SELECT] key - Move each part out of the interference area - Change the setting for SELF INTERFERENCE RELEASE from "VALID" to "INVALID" by [SELECT] key NOTE) Be sure to check the operation direction since the above operations enable manipulator's parts to interfere with each other.
4623	WRONG EXECUTION OF GETPOS INST	1	An attempt was made to obtain the step that used a local position type variable. (The step with local position type variable cannot be fetched. Example: MOVJ LP000 VJ=25.00)	Setting error	(1)Check the following settings. ·Check the settings for the GETPOS instruction.
		2	An attempt was made to obtain the step that used a local position type variable. (The step with local position type variable cannot be fetched. Example: MOVJ LP000 VJ=25.00)	Setting error	(1)Check the following settings. ·Check the settings for the GETPOS instruction.
		3	The specified step did not exist.	Setting error	(1)Check the following settings. ·Check the settings for the GETPOS instruction.
4628	WRITE VARIABLE NO. MULTI SETTING		Sub Code: Duplicated variable number	Setting error	(1)Check the following settings. ·Check the settings for the written destination variable numbers.
4629	GROUP CHANGE ERROR	1	The group change parameter was invalid.	Setting error	(1)Check the following settings. ·Validate the group change parameter.
		2	The GRPCHG instruction was executed while the external axis motor was servo ON.	Setting error	(1)Check the following settings. ·Execute the GRPCHG instruction when the external axis motor was servo OFF.
		3	The GRPCHG instruction was executed in unchuck status.	Setting error	(1)Check the following settings. ·Execute the GRPCHG instruction in chuck status.

Alarm Number	Alarm Name	Sub Code	Meaning	Cause	Remedy
		4	The group identification signal was not received.	Setting error	(1)Check the following settings. ·Check the settings for group identification signal.
		5	The specified control group number and the group identification number were unmatched.	Setting error	(1)Check the following settings. ·Check the settings for the specified control group number.
		6	The encoder PG power supply was OFF when the GRPCHG was ON.	Setting error	(1)Check the following settings. ·Turn ON the encoder PG power supply when GRPCHG is ON.
		7	The encoder PG power supply was ON when the GRPCHG was OFF.	Setting error	(1)Check the following settings. ·Turn OFF the encoder PG power supply when GRPCHG is OFF.
		8	The control group that corresponded to the received group identification signal did not exist.	Setting error	(1)Check the following settings. ·Check the settings for group identification signal.
4632	UNDEFINED LNR SCALE FILE		Sub Code: Linear scale characteristic file number	Setting error	(1)Check the following settings. ·Complete the settings for the linear scale condition file.
4635	CANNOT EXECUTE COMMON JOB		Sub Code: The related control-group	Setting error	(1)Check the following settings. ·Check the settings for control group specified by the CALL instruction.
4637	TRACK CHG WORK IN/ NOT NOT FOUND		Sub Code: Conveyor characteristic file number	Setting error	(1)Check the following settings. ·Check the workpiece presence/absence and data settings for the synchronization section.
4638	TRACKING CHG WORK ID NOT FOUND		Sub Code: Conveyor characteristic file number	Setting error	(1)Check the following settings. ·Check the workpiece presence/absence and data settings for the synchronization section.
4639	SYMOVJ INST EXECUTE ERROR	2	The conveyor moving amount is not specified for the SYMOVJ motion.	Setting error	(1)Check the following settings. ·Set the conveyor moving amount for the SYMOVJ motion.
		3	An error occurred in the preparation process of the manipulator motion start position for the SYMOVJ motion.	Software operation error occurred	(1)Reset the alarm, and then try again. (2)If the alarm occurs again, save the CMOS.BIN in maintenance mode, and then contact your Yaskawa representative about occurrence status (operating procedure).
		4	An error occurred in the preparation process of the manipulator motion end position for the SYMOVJ motion.	Software operation error occurred	(1)Reset the alarm, and then try again. (2)If the alarm occurs again, save the CMOS.BIN in maintenance mode, and then contact your Yaskawa representative about occurrence status (operating procedure).
4640	WRONG EXECUTION OF PSTART INST	1	No axis data of control group to be disconnected	Setting error	(1)Check the following settings. ·Check the settings for PSTART instruction.

Alarm Number	Alarm Name	Sub Code	Meaning	Cause	Remedy
		2	An attempt was made to disconnect a control group other than the occupation control group during prereading processing.	Setting error	(1)Check the following settings. ·Check the settings for PSTART instruction.
		3	An attempt was made to disconnect a control group other than the occupation control group when executing a PSTART instruction.	Setting error	(1)Check the following settings. ·Check the settings for PSTART instruction.
4641	CANNOT EXECUTE JOB (SEPARATE GRP)		Sub Code: The disconnected control group used by a move instruction	Setting error	(1)Check the following settings. ·Correct the teaching so that the control group disconnected by itself is not to operate for move instruction of own system.
4649	PARTIAL OPERATION AREA INTERFERENCE		Sub Code: Interference control group number & interference axis & interference area number.	Setting error	(1)Check the following settings. ·Check the teaching position setting of manipulators.
4650	TRQ CLEAR ERROR			Software operation error occurred	(1)Reset the alarm, and then try again. (2)If the alarm occurs again, save the CMOS.BIN in maintenance mode, and then contact your Yaskawa representative about occurrence status (operating procedure).
4651	PALLETIZING EXECUTE ERROR	1	The setting of the pelletizing condition configuration file is incomplete.	Setting error	(1)Check the following settings. ·Set the pelletizing condition setting file to "Completed".
		4	Pelletize completion universal output number range exceeds the limit.	Setting error	(1)Check the following settings. ·Change the pelletize completion universal output signal number of the pelletizing condition setting file in the user output signal point of contact number.
		5	During the pelletize start instruction execution, the pelletize start instruction is executed again (double execution).	Setting error	(1)Check the following settings. ·Delete the pelletize start instruction in the pelletize section.
		6	The value of the pelletizing number present value output register (or I variable) is more than the total number output register (or I variable).	Setting error	(1)Check the following settings. ·Check if the pelletizing number of current position output register (or I variable) and total number of output register (or I variable) is not changed by another function.
		7	Pelletize completion universal output signal is turned ON at pelletize start instruction execution.	Setting error	(1)Check the following settings. ·Reset the pelletize completion universal output signal.
		8	Pelletize end instruction is not registered.	Setting error	(1)Check the following settings. ·Register the pelletizing end instruction.

Alarm Number	Alarm Name	Sub Code	Meaning	Cause	Remedy
4652	TRQ MEASURE MODE SET ERROR(SV)			Software operation error occurred	(1)Reset the alarm, and then try again. (2)If the alarm occurs again, save the CMOS.BIN in maintenance mode, and then contact your Yaskawa representative about occurrence status (operating procedure).
4653	TRQ MEASURE MODE CANCEL ERROR(SV)			Software operation error occurred	(1)Reset the alarm, and then try again. (2)If the alarm occurs again, save the CMOS.BIN in maintenance mode, and then contact your Yaskawa representative about occurrence status (operating procedure).
4654	WRONG EXECUTION OF SETREG INST	1	An attempt was made to change the value of the register currently used by TMR/CNT.	Setting error	(1)Check the following settings. ·The SETREGM instruction cannot change the register values used in TMR/ CNT. Correct the setting of tag that specifies register number of SETREG instruction.
4655	WRONG EXECUTION OF GETREG INST	1	An attempt was made to acquire the value of the register not existing.	Software operation error occurred	(1)Reset the alarm, and then try again. (2)If the alarm occurs again, save the CMOS.BIN in maintenance mode, and then contact your Yaskawa representative about occurrence status (operating procedure).
4656	WRONG EXECUTION OF SETPRM INST	1	An attempt was made to change a parameter other than the cube-related parameter.	Setting error	(1)Check the following settings. ·The SETPRM instruction cannot change the parameter values other than the parameter related to the cube. Correct the setting of tag that specifies parameter number of SETPRM instruction.
		2	The SETPRM instruction was executed while another system was in execution.	Setting error	(1)Check the following settings. ·The SETPRM instruction cannot execute while another system is operating. Correct the job.
4670	INSUFFICIENT NUM OF SAMPLE DATA		Sub Code: Signifies the axis in which the alarm occurred	Setting error	Lengthen the measurement section.
4671	SAMPLE BUFFER OVER FLOW		Sub Code: Signifies the axis in which the alarm occurred	Setting error	Shorten the measurement section.
4672	BASIC SPEED UNREACHED		Sub Code: Signifies the axis in which the alarm occurred	Setting error	Increase the speed specification value of a measurement job or set a small value for BASICV. Or set a small value for BASICT, or lengthen the measurement section.
4673	MAX TRQ UNDETECTED		Sub Code: Signifies the axis in which the alarm occurred	Setting error	Set a large value for the BASICT, and then check again.
4676	BROKEN FAN FUSE		Sub Code: Signifies the YSU unit number in which the alarm occurred	Connection failure	(1)Reset the alarm. (2)If the alarm occurs again, check if there is a ground fault or short circuit in the fan power line.
				Fuse failure	(After cancellation of the short-circuit and ground fault) Replace the fuse.

Alarm Number	Alarm Name	Sub Code	Meaning	Cause	Remedy
4677	IMPOSSIBLE LINEAR MOTION		Sub Code: Control group and axis	Setting error	(1)Check the following settings. ·If the sub code display is L- and U-axes, perform the teaching again to make the form (arm folded direction) of L- and U-axes same at start point and end point. ·If the sub code display is S- and L-axes, perform the teaching again to make the form (arm folded direction) of S- and L-axes same at start point and end point. ·Change the teaching move instruction to MOVJ instruction. *Be carefull to the interferences with peripheral environment, because the robot changes its motion.
4681	OVER SPEED (MainCPU)		Sub Code: Control group and axis	Setting error	(1)Check the following settings. ·Reduce the speed of the step where the alarm occurred. ·Change the move instruction to joint interpolation (MOVJ). * Be careful to the peripheral interference since its movement changes.
4682	MOTION RANGE LIMIT INTERFERENCE		Sub Code: Manipulator number	Setting error	(1)Check the following settings. ·Modify the teaching position or widen the operation area so that the robot would not interfere with the operation area. ·Confirm the setting of the robot tool mode (tool interference file) which the control group is indicated.
4683	AXIS MOTION RANGE LIMIT OVER(MIN./MAX.)		Sub Code: Control group and axis	Setting error	(1)Check the following settings. ·Modify the teaching position or widen the operation area so that the robot would not interfere with the operation area. ·Confirm the setting of the operation area which the control group is indicated by the sub code.
4684	INTERPOLATION INVALID		Sub Code: Control group	Setting error	(1)Check the following settings. ·At the cartesian jog operation, switch to each-axes jog operations, and then change the orientation of manipulator. ·Change the teaching position and orientation.
4696	TURN TABLE CALIBRATION ERROR	1	There was the same point in three points where the calibration had been executed.	Setting error	(1)Check the following settings. ·Correct the calibration position so that each point is different.
		2	The three points where the calibration had been executed lie in a straight line.	Setting error	(1)Check the following settings. ·Check the calibration position so that the three taught points are not aligned in a straight line.
		3	The three points where the calibration had been executed lie in a straight line.	Setting error	(1)Check the following settings. ·Check the calibration position so that the three taught points are not aligned in a straight line.
4697	OFFLINE ARM BEND POS CONVERT ERROR	1	Incorrect information of standard position data for offline arm bend position data conversion	Software operation error occurred	(1)Reset the alarm, and then try again. (2)If the alarm occurs again, save the CMOS.BIN in maintenance mode, and then contact your Yaskawa representative about occurrence status (operating procedure).

Alarm Number	Alarm Name	Sub Code	Meaning	Cause	Remedy
		3	Incorrect reference-point data offline arm bend position data conversion	Software operation error occurred	(1)Reset the alarm, and then try again. (2)If the alarm occurs again, save the CMOS.BIN in maintenance mode, and then contact your Yaskawa representative about occurrence status (operating procedure).
		4	The position data could not be converted correctly/conversely for the standard position data at the offline arm bend position data conversion.	Setting error	(1)Check the following settings. ·The variable position may be out of the robot motion range. Check if the variable position is within the robot motion range.
		5	Incorrect pulse incremental value for offline arm bend position data conversion	Setting error	(1)Check the following settings. ·The variable position may be out of the robot motion range. Check if the variable position is within the robot motion range.
		6	The position data could not be converted correctly for the pulse incremental value at the offline arm bend position data conversion.	Setting error	(1)Check the following settings. ·The variable position may be out of the robot motion range. Check if the variable position is within the robot motion range.
		7	Incorrect Cartesian incremental value for offline arm bend position data conversion	Setting error	(1)Check the following settings. ·The variable position may be out of the robot motion range. Check if the variable position is within the robot motion range.
		8	The position data could not be converted correctly for the Cartesian incremental value at the offline arm bend position data conversion.	Setting error	(1)Check the following settings. ·The variable position may be out of the robot motion range. Check if the variable position is within the robot motion range.
		9	The position conversion could not be done in the conversion data for offline arm bend position data conversion.	Setting error	(1)Check the following settings. ·The variable position may be out of the robot motion range. Check if the variable position is within the robot motion range.
		10	Incorrect incremental value of angle for offline arm bend position data conversion	Setting error	(1)Check the following settings. ·The variable position may be out of the robot motion range. Check if the variable position is within the robot motion range.
		11	The position data could not be converted correctly for the incremental value of angle at the offline arm bend position data conversion.	Setting error	(1)Check the following settings. ·The variable position may be out of the robot motion range. Check if the variable position is within the robot motion range.
		14	The reverse shift value creation at the offline position data conversion failure	Setting error	(1)Check the following settings. ·The variable position may be out of the robot motion range. Check if the variable position is within the robot motion range.
		15	The reverse shift value adding failure at the offline position data conversion	Setting error	(1)Check the following settings. ·The variable position may be out of the robot motion range. Check if the variable position is within the robot motion range.

Alarm Number	Alarm Name	Sub Code	Meaning	Cause	Remedy
		17	The shift value adding failure at the offline position data conversion	Setting error	(1)Check the following settings. ·The variable position may be out of the robot motion range. Check if the variable position is within the robot motion range.
		19	Mirror shift correctly/conversely conversion for the offline position data conversion error	Setting error	(1)Check the following settings. ·The variable position may be out of the robot motion range. Check if the variable position is within the robot motion range.
		20	Mirror shift position conversion for the offline position data conversion error	Setting error	(1)Check the following settings. ·The variable position may be out of the robot motion range. Check if the variable position is within the robot motion range.
		22	Coordinate specification error in the new mirror shift conversion for the offline position data conversion	Setting error	(1)Check the following settings. ·The variable position may be out of the robot motion range. Check if the variable position is within the robot motion range.
4698	SHIFT VALUE MAKING ERROR	1	Reference position and target position occupation control-group error	Software operation error occurred	(1)Reset the alarm, and then try again. (2)If the alarm occurs again, save the CMOS.BIN in maintenance mode, and then contact your Yaskawa representative about occurrence status (operating procedure).
		2	Reference position and target position enabling control-group error	Software operation error occurred	(1)Reset the alarm, and then try again. (2)If the alarm occurs again, save the CMOS.BIN in maintenance mode, and then contact your Yaskawa representative about occurrence status (operating procedure).
		3	The position data type is not applicable.	Software operation error occurred	(1)Reset the alarm, and then try again. (2)If the alarm occurs again, save the CMOS.BIN in maintenance mode, and then contact your Yaskawa representative about occurrence status (operating procedure).
		4	Coordinated control-group error	Software operation error occurred	(1)Reset the alarm, and then try again. (2)If the alarm occurs again, save the CMOS.BIN in maintenance mode, and then contact your Yaskawa representative about occurrence status (operating procedure).
		5	User coordinates number on the specified tag side error	Software operation error occurred	(1)Reset the alarm, and then try again. (2)If the alarm occurs again, save the CMOS.BIN in maintenance mode, and then contact your Yaskawa representative about occurrence status (operating procedure).
4715	CIP MESSAGE SERVER FUNC ERROR	1	Failed in the generation of the CIP server task.	Software operation error occurred	(1)Reset the alarm, and then try again. (2)If the alarm occurs again, save the CMOS.BIN in maintenance mode, and then contact your Yaskawa representative about occurrence status (operating procedure).
		2	Failed in the ID take of the CIP server task.	Software operation error occurred	(1)Reset the alarm, and then try again. (2)If the alarm occurs again, save the CMOS.BIN in maintenance mode, and then contact your Yaskawa representative about occurrence status (operating procedure).

Alarm Number	Alarm Name	Sub Code	Meaning	Cause	Remedy
		3	Failed in the generation of the class entry table.	Software operation error occurred	(1)Reset the alarm, and then try again. (2)If the alarm occurs again, save the CMOS.BIN in maintenance mode, and then contact your Yaskawa representative about occurrence status (operating procedure).
		4	Library initialize error.	Software operation error occurred	(1)Reset the alarm, and then try again. (2)If the alarm occurs again, save the CMOS.BIN in maintenance mode, and then contact your Yaskawa representative about occurrence status (operating procedure).
		5	Failed in the generation of the access process.	Software operation error occurred	(1)Reset the alarm, and then try again. (2)If the alarm occurs again, save the CMOS.BIN in maintenance mode, and then contact your Yaskawa representative about occurrence status (operating procedure).
		10	Detect undefined error.	Software operation error occurred	(1)Reset the alarm, and then try again. (2)If the alarm occurs again, save the CMOS.BIN in maintenance mode, and then contact your Yaskawa representative about occurrence status (operating procedure).
		20	Detect sever function started processing.	Software operation error occurred	(1)Reset the alarm, and then try again. (2)If the alarm occurs again, save the CMOS.BIN in maintenance mode, and then contact your Yaskawa representative about occurrence status (operating procedure).
		30	Detect request error.	Software operation error occurred	(1)Reset the alarm, and then try again. (2)If the alarm occurs again, save the CMOS.BIN in maintenance mode, and then contact your Yaskawa representative about occurrence status (operating procedure).
		31	Detect memory error.	Software operation error occurred	(1)Reset the alarm, and then try again. (2)If the alarm occurs again, save the CMOS.BIN in maintenance mode, and then contact your Yaskawa representative about occurrence status (operating procedure).
		32	Detect mail send error.	Software operation error occurred	(1)Reset the alarm, and then try again. (2)If the alarm occurs again, save the CMOS.BIN in maintenance mode, and then contact your Yaskawa representative about occurrence status (operating procedure).
		33	Detect CIP answer error.	Software operation error occurred	(1)Reset the alarm, and then try again. (2)If the alarm occurs again, save the CMOS.BIN in maintenance mode, and then contact your Yaskawa representative about occurrence status (operating procedure).

Alarm Number	Alarm Name	Sub Code	Meaning	Cause	Remedy
		40	Detect CIP server task mail receive error.	Software operation error occurred	(1)Reset the alarm, and then try again. (2)If the alarm occurs again, save the CMOS.BIN in maintenance mode, and then contact your Yaskawa representative about occurrence status (operating procedure).
		41	Detect CIP server task request data error.	Software operation error occurred	(1)Reset the alarm, and then try again. (2)If the alarm occurs again, save the CMOS.BIN in maintenance mode, and then contact your Yaskawa representative about occurrence status (operating procedure).
		50	Detect CIP server task send error.	Software operation error occurred	(1)Reset the alarm, and then try again. (2)If the alarm occurs again, save the CMOS.BIN in maintenance mode, and then contact your Yaskawa representative about occurrence status (operating procedure).
4716	BINARY ETHERNET SERVER FUNC ERR	1	IP address duplicated.	IP address setting error	(1)Reset the alarm, and then try again. (2)The IP address is duplicated with the FS100 controller. Confirm the IP address of the communication target. (3)If the alarm occurs again, save the CMOS.BIN in maintenance mode, and then contact your Yaskawa representative about occurrence status (operating procedure).
			Detect message library initialize error.	Software operation error occurred	(1)Reset the alarm, and then try again. (2)If the alarm occurs again, save the CMOS.BIN in maintenance mode, and then contact your Yaskawa representative about occurrence status (operating procedure).
		2	Failed in the generation of the RC connect management task.	Software operation error occurred	(1)Reset the alarm, and then try again. (2)If the alarm occurs again, save the CMOS.BIN in maintenance mode, and then contact your Yaskawa representative about occurrence status (operating procedure).
		3	Failed in the generation of the RC server task.	Software operation error occurred	(1)Reset the alarm, and then try again. (2)If the alarm occurs again, save the CMOS.BIN in maintenance mode, and then contact your Yaskawa representative about occurrence status (operating procedure).
		4	Failed in the generation of the file server task.	Software operation error occurred	(1)Reset the alarm, and then try again. (2)If the alarm occurs again, save the CMOS.BIN in maintenance mode, and then contact your Yaskawa representative about occurrence status (operating procedure).
		1040	Failed in the request take of the RC connect management task.	Software operation error occurred	(1)Reset the alarm, and then try again. (2)If the alarm occurs again, save the CMOS.BIN in maintenance mode, and then contact your Yaskawa representative about occurrence status (operating procedure).

Alarm Number	Alarm Name	Sub Code	Meaning	Cause	Remedy
		1041	Failed in the endian conversion.	Software operation error occurred	(1)Reset the alarm, and then try again. (2)If the alarm occurs again, save the CMOS.BIN in maintenance mode, and then contact your Yaskawa representative about occurrence status (operating procedure).
		1042	Received data area overflow.	Software operation error occurred	(1)Reset the alarm, and then try again. (2)If the alarm occurs again, save the CMOS.BIN in maintenance mode, and then contact your Yaskawa representative about occurrence status (operating procedure).
		1043	Failed in the request error.	Software operation error occurred	(1)Reset the alarm, and then try again. (2)If the alarm occurs again, save the CMOS.BIN in maintenance mode, and then contact your Yaskawa representative about occurrence status (operating procedure).
		1044	Failed in the request error.	Software operation error occurred	(1)Reset the alarm, and then try again. (2)If the alarm occurs again, save the CMOS.BIN in maintenance mode, and then contact your Yaskawa representative about occurrence status (operating procedure).
		1059	In a RC connect management task,undefine error detected.	Software operation error occurred	(1)Reset the alarm, and then try again. (2)If the alarm occurs again, save the CMOS.BIN in maintenance mode, and then contact your Yaskawa representative about occurrence status (operating procedure).
		1060	Failed in the ID take of the RC server task.	Software operation error occurred	(1)Reset the alarm, and then try again. (2)If the alarm occurs again, save the CMOS.BIN in maintenance mode, and then contact your Yaskawa representative about occurrence status (operating procedure).
		1061	Failed in the mail take of the RC server task.	Software operation error occurred	(1)Reset the alarm, and then try again. (2)If the alarm occurs again, save the CMOS.BIN in maintenance mode, and then contact your Yaskawa representative about occurrence status (operating procedure).
		1062	In a RC server task, request mail data error detected.	Software operation error occurred	(1)Reset the alarm, and then try again. (2)If the alarm occurs again, save the CMOS.BIN in maintenance mode, and then contact your Yaskawa representative about occurrence status (operating procedure).
		1063	Answer data area overflow.	Software operation error occurred	(1)Reset the alarm, and then try again. (2)If the alarm occurs again, save the CMOS.BIN in maintenance mode, and then contact your Yaskawa representative about occurrence status (operating procedure).

Alarm Number	Alarm Name	Sub Code	Meaning	Cause	Remedy
		1064	In a RC server task, receive data area overflow.	Software operation error occurred	(1)Reset the alarm, and then try again. (2)If the alarm occurs again, save the CMOS.BIN in maintenance mode, and then contact your Yaskawa representative about occurrence status (operating procedure).
		1079	In a RC server task, undefined error detected.	Software operation error occurred	(1)Reset the alarm, and then try again. (2)If the alarm occurs again, save the CMOS.BIN in maintenance mode, and then contact your Yaskawa representative about occurrence status (operating procedure).
		1080	In a file server task, mail receive error detected.	Software operation error occurred	(1)Reset the alarm, and then try again. (2)If the alarm occurs again, save the CMOS.BIN in maintenance mode, and then contact your Yaskawa representative about occurrence status (operating procedure).
		1081	In a file server task, request mail data error detected.	Software operation error occurred	(1)Reset the alarm, and then try again. (2)If the alarm occurs again, save the CMOS.BIN in maintenance mode, and then contact your Yaskawa representative about occurrence status (operating procedure).
		1082	IP address duplicated.	IP address setting error	(1)Reset the alarm, and then try again. (2)The IP address is duplicated with the FS100 controller. Confirm the IP address of the communication target. (3)If the alarm occurs again, save the CMOS.BIN in maintenance mode, and then contact your Yaskawa representative about occurrence status (operating procedure).
			In a file server task, request error occurred.	Software operation error occurred	(1)Reset the alarm, and then try again. (2)If the alarm occurs again, save the CMOS.BIN in maintenance mode, and then contact your Yaskawa representative about occurrence status (operating procedure).
		1083	Failed in the endian conversion.	Software operation error occurred	(1)Reset the alarm, and then try again. (2)If the alarm occurs again, save the CMOS.BIN in maintenance mode, and then contact your Yaskawa representative about occurrence status (operating procedure).
		1084	In a file server task, receive data area overflow.	Software operation error occurred	(1)Reset the alarm, and then try again. (2)If the alarm occurs again, save the CMOS.BIN in maintenance mode, and then contact your Yaskawa representative about occurrence status (operating procedure).
		2045	In a RC connect management task , send error detected.	Software operation error occurred	(1)Reset the alarm, and then try again. (2)If the alarm occurs again, save the CMOS.BIN in maintenance mode, and then contact your Yaskawa representative about occurrence status (operating procedure).

Alarm Number	Alarm Name	Sub Code	Meaning	Cause	Remedy
		2046	Failed in the endian conversion.	Software operation error occurred	(1)Reset the alarm, and then try again. (2)If the alarm occurs again, save the CMOS.BIN in maintenance mode, and then contact your Yaskawa representative about occurrence status (operating procedure).
		2065	Detect RC server task send error.	Software operation error occurred	(1)Reset the alarm, and then try again. (2)If the alarm occurs again, save the CMOS.BIN in maintenance mode, and then contact your Yaskawa representative about occurrence status (operating procedure).
		2066	Failed in the endian conversion.	Software operation error occurred	(1)Reset the alarm, and then try again. (2)If the alarm occurs again, save the CMOS.BIN in maintenance mode, and then contact your Yaskawa representative about occurrence status (operating procedure).
		2085	Detect file server task send error.	Software operation error occurred	(1)Reset the alarm, and then try again. (2)If the alarm occurs again, save the CMOS.BIN in maintenance mode, and then contact your Yaskawa representative about occurrence status (operating procedure).
		2086	Failed in the endian conversion.	Software operation error occurred	(1)Reset the alarm, and then try again. (2)If the alarm occurs again, save the CMOS.BIN in maintenance mode, and then contact your Yaskawa representative about occurrence status (operating procedure).
		2087	In a file server task, answer data error detected.	Software operation error occurred	(1)Reset the alarm, and then try again. (2)If the alarm occurs again, save the CMOS.BIN in maintenance mode, and then contact your Yaskawa representative about occurrence status (operating procedure).
		2088	Failed in the endian conversion.	Software operation error occurred	(1)Reset the alarm, and then try again. (2)If the alarm occurs again, save the CMOS.BIN in maintenance mode, and then contact your Yaskawa representative about occurrence status (operating procedure).
		2089	In a file server task, answer data area overflow.	Software operation error occurred	(1)Reset the alarm, and then try again. (2)If the alarm occurs again, save the CMOS.BIN in maintenance mode, and then contact your Yaskawa representative about occurrence status (operating procedure).
		2098	Failed in the status error occurred.	Software operation error occurred	(1)Reset the alarm, and then try again. (2)If the alarm occurs again, save the CMOS.BIN in maintenance mode, and then contact your Yaskawa representative about occurrence status (operating procedure).

Alarm Number	Alarm Name	Sub Code	Meaning	Cause	Remedy
		2099	In a file server task, undefined error detected.	Software operation error occurred	(1)Reset the alarm, and then try again. (2)If the alarm occurs again, save the CMOS.BIN in maintenance mode, and then contact your Yaskawa representative about occurrence status (operating procedure).
		3090	In a file sever task, file close error.	Software operation error occurred	(1)Reset the alarm, and then try again. (2)If the alarm occurs again, save the CMOS.BIN in maintenance mode, and then contact your Yaskawa representative about occurrence status (operating procedure).
4718	BINARY ETHERNET CLIENT FUNC ERR	1	Detect message library initialize error.	Software operation error occurred	(1)Reset the alarm, and then try again. (2)If the alarm occurs again, save the CMOS.BIN in maintenance mode, and then contact your Yaskawa representative about occurrence status (operating procedure).
		2	Failed in the generation of the file function task.	Software operation error occurred	(1)Reset the alarm, and then try again. (2)If the alarm occurs again, save the CMOS.BIN in maintenance mode, and then contact your Yaskawa representative about occurrence status (operating procedure).
		3	Failed in the generation of the RC function task.	Software operation error occurred	(1)Reset the alarm, and then try again. (2)If the alarm occurs again, save the CMOS.BIN in maintenance mode, and then contact your Yaskawa representative about occurrence status (operating procedure).
		4	Detect I/F data error.	Software operation error occurred	(1)Reset the alarm, and then try again. (2)If the alarm occurs again, save the CMOS.BIN in maintenance mode, and then contact your Yaskawa representative about occurrence status (operating procedure).
		10	Detect undefined error.	Software operation error occurred	(1)Reset the alarm, and then try again. (2)If the alarm occurs again, save the CMOS.BIN in maintenance mode, and then contact your Yaskawa representative about occurrence status (operating procedure).
		110	In a file task, undefined error detected.	Software operation error occurred	(1)Reset the alarm, and then try again. (2)If the alarm occurs again, save the CMOS.BIN in maintenance mode, and then contact your Yaskawa representative about occurrence status (operating procedure).
		510	In a RC task, undefined error detected.	Software operation error occurred	(1)Reset the alarm, and then try again. (2)If the alarm occurs again, save the CMOS.BIN in maintenance mode, and then contact your Yaskawa representative about occurrence status (operating procedure).

Alarm Number	Alarm Name	Sub Code	Meaning	Cause	Remedy
		511	In a RC task, request command error detected.	Software operation error occurred	(1)Reset the alarm, and then try again. (2)If the alarm occurs again, save the CMOS.BIN in maintenance mode, and then contact your Yaskawa representative about occurrence status (operating procedure).
		512	In RC task, there is not the class entry of the request command.	Software operation error occurred	(1)Reset the alarm, and then try again. (2)If the alarm occurs again, save the CMOS.BIN in maintenance mode, and then contact your Yaskawa representative about occurrence status (operating procedure).
		513	In RC task, there is not the service entry of the request command.	Software operation error occurred	(1)Reset the alarm, and then try again. (2)If the alarm occurs again, save the CMOS.BIN in maintenance mode, and then contact your Yaskawa representative about occurrence status (operating procedure).
		1130	In a high speed Ethernet task, request mail error detected.	Software operation error occurred	(1)Reset the alarm, and then try again. (2)If the alarm occurs again, save the CMOS.BIN in maintenance mode, and then contact your Yaskawa representative about occurrence status (operating procedure).
		1131	In a high speed Ethernet task, request command error detected.	Software operation error occurred	(1)Reset the alarm, and then try again. (2)If the alarm occurs again, save the CMOS.BIN in maintenance mode, and then contact your Yaskawa representative about occurrence status (operating procedure).
		1132	In a file task, mail receive error occurred.	Software operation error occurred	(1)Reset the alarm, and then try again. (2)If the alarm occurs again, save the CMOS.BIN in maintenance mode, and then contact your Yaskawa representative about occurrence status (operating procedure).
		2140	In a file task, file reading error occurred.	Software operation error occurred	(1)Reset the alarm, and then try again. (2)If the alarm occurs again, save the CMOS.BIN in maintenance mode, and then contact your Yaskawa representative about occurrence status (operating procedure).
		2141	In a file task, file writing error occurred.	Software operation error occurred	(1)Reset the alarm, and then try again. (2)If the alarm occurs again, save the CMOS.BIN in maintenance mode, and then contact your Yaskawa representative about occurrence status (operating procedure).
		3150	In a file task, request send error occurred.	Software operation error occurred	(1)Reset the alarm, and then try again. (2)If the alarm occurs again, save the CMOS.BIN in maintenance mode, and then contact your Yaskawa representative about occurrence status (operating procedure).

Alarm Number	Alarm Name	Sub Code	Meaning	Cause	Remedy
		3151	Failed in the endian conversion.	Software operation error occurred	(1)Reset the alarm, and then try again. (2)If the alarm occurs again, save the CMOS.BIN in maintenance mode, and then contact your Yaskawa representative about occurrence status (operating procedure).
		3160	In a file task, reply packet clear error occurred.	Software operation error occurred	(1)Reset the alarm, and then try again. (2)If the alarm occurs again, save the CMOS.BIN in maintenance mode, and then contact your Yaskawa representative about occurrence status (operating procedure).
		3161	Failed in the take of the reply packet data error.	Software operation error occurred	(1)Reset the alarm, and then try again. (2)If the alarm occurs again, save the CMOS.BIN in maintenance mode, and then contact your Yaskawa representative about occurrence status (operating procedure).
		3162	Failed in the endian conversion.	Software operation error occurred	(1)Reset the alarm, and then try again. (2)If the alarm occurs again, save the CMOS.BIN in maintenance mode, and then contact your Yaskawa representative about occurrence status (operating procedure).
		3163	In a file task, time out occurred.	Software operation error occurred	(1)Reset the alarm, and then try again. (2)If the alarm occurs again, save the CMOS.BIN in maintenance mode, and then contact your Yaskawa representative about occurrence status (operating procedure).
		3164	In a file task, receive data area overflow occurred.	Software operation error occurred	(1)Reset the alarm, and then try again. (2)If the alarm occurs again, save the CMOS.BIN in maintenance mode, and then contact your Yaskawa representative about occurrence status (operating procedure).
		3165	In a file task, received data unmatched.	Software operation error occurred	(1)Reset the alarm, and then try again. (2)If the alarm occurs again, save the CMOS.BIN in maintenance mode, and then contact your Yaskawa representative about occurrence status (operating procedure).
		3166	In a file task, receive data size overflow occurred.	Software operation error occurred	(1)Reset the alarm, and then try again. (2)If the alarm occurs again, save the CMOS.BIN in maintenance mode, and then contact your Yaskawa representative about occurrence status (operating procedure).
		3167	In a file task, received data size set to zero occurred.	Software operation error occurred	(1)Reset the alarm, and then try again. (2)If the alarm occurs again, save the CMOS.BIN in maintenance mode, and then contact your Yaskawa representative about occurrence status (operating procedure).

Alarm Number	Alarm Name	Sub Code	Meaning	Cause	Remedy
		3168	In a file task, reply head error occurred.	Software operation error occurred	(1)Reset the alarm, and then try again. (2)If the alarm occurs again, save the CMOS.BIN in maintenance mode, and then contact your Yaskawa representative about occurrence status (operating procedure).
		3169	In a file task, reply status error occurred.	Software operation error occurred	(1)Reset the alarm, and then try again. (2)If the alarm occurs again, save the CMOS.BIN in maintenance mode, and then contact your Yaskawa representative about occurrence status (operating procedure).
		5530	In a RC task, interface request error occurred.	Software operation error occurred	(1)Reset the alarm, and then try again. (2)If the alarm occurs again, save the CMOS.BIN in maintenance mode, and then contact your Yaskawa representative about occurrence status (operating procedure).
		5531	In a RC task, interface answer error occurred.	Software operation error occurred	(1)Reset the alarm, and then try again. (2)If the alarm occurs again, save the CMOS.BIN in maintenance mode, and then contact your Yaskawa representative about occurrence status (operating procedure).
		5532	In a RC task, interface data area overflow occurred.	Software operation error occurred	(1)Reset the alarm, and then try again. (2)If the alarm occurs again, save the CMOS.BIN in maintenance mode, and then contact your Yaskawa representative about occurrence status (operating procedure).
		5533	In a RC task, interface data writing error occurred.	Software operation error occurred	(1)Reset the alarm, and then try again. (2)If the alarm occurs again, save the CMOS.BIN in maintenance mode, and then contact your Yaskawa representative about occurrence status (operating procedure).
		6540	In a RC task, time out occurred.	Software operation error occurred	(1)Reset the alarm, and then try again. (2)If the alarm occurs again, save the CMOS.BIN in maintenance mode, and then contact your Yaskawa representative about occurrence status (operating procedure).
		6541	Detect data error.	Software operation error occurred	(1)Reset the alarm, and then try again. (2)If the alarm occurs again, save the CMOS.BIN in maintenance mode, and then contact your Yaskawa representative about occurrence status (operating procedure).
		6542	Detect exclusive process error.	Software operation error occurred	(1)Reset the alarm, and then try again. (2)If the alarm occurs again, save the CMOS.BIN in maintenance mode, and then contact your Yaskawa representative about occurrence status (operating procedure).

Alarm Number	Alarm Name	Sub Code	Meaning	Cause	Remedy
		6543	Detect time out.	Software operation error occurred	(1)Reset the alarm, and then try again. (2)If the alarm occurs again, save the CMOS.BIN in maintenance mode, and then contact your Yaskawa representative about occurrence status (operating procedure).
		6544	Setting error	Setting error	(1)Reset the alarm, and confirm whether the following parameter is set to zero. · S2C541 · S2C542
			Detect data error.	Software operation error occurred	(1)Reset the alarm, and then try again. (2)If the alarm occurs again, save the CMOS.BIN in maintenance mode, and then contact your Yaskawa representative about occurrence status (operating procedure).
		6545	Detect exclusive process error.	Software operation error occurred	(1)Reset the alarm, and then try again. (2)If the alarm occurs again, save the CMOS.BIN in maintenance mode, and then contact your Yaskawa representative about occurrence status (operating procedure).
		7550	In a RC task, request send error occurred.	Software operation error occurred	(1)Reset the alarm, and then try again. (2)If the alarm occurs again, save the CMOS.BIN in maintenance mode, and then contact your Yaskawa representative about occurrence status (operating procedure).
		7551	Failed in the endian conversion.	Software operation error occurred	(1)Reset the alarm, and then try again. (2)If the alarm occurs again, save the CMOS.BIN in maintenance mode, and then contact your Yaskawa representative about occurrence status (operating procedure).
		7560	In a RC task, reply packet error detected.	Software operation error occurred	(1)Reset the alarm, and then try again. (2)If the alarm occurs again, save the CMOS.BIN in maintenance mode, and then contact your Yaskawa representative about occurrence status (operating procedure).
		7561	In a RC task, reply take error detected.	Software operation error occurred	(1)Reset the alarm, and then try again. (2)If the alarm occurs again, save the CMOS.BIN in maintenance mode, and then contact your Yaskawa representative about occurrence status (operating procedure).
		7562	Failed in the endian conversion.	Software operation error occurred	(1)Reset the alarm, and then try again. (2)If the alarm occurs again, save the CMOS.BIN in maintenance mode, and then contact your Yaskawa representative about occurrence status (operating procedure).

Alarm Number	Alarm Name	Sub Code	Meaning	Cause	Remedy
		7563	Detect time out.	Software operation error occurred	(1)Reset the alarm, and then try again. (2)If the alarm occurs again, save the CMOS.BIN in maintenance mode, and then contact your Yaskawa representative about occurrence status (operating procedure).
		7564	In a RC task, receive data area overflow detected.	Software operation error occurred	(1)Reset the alarm, and then try again. (2)If the alarm occurs again, save the CMOS.BIN in maintenance mode, and then contact your Yaskawa representative about occurrence status (operating procedure).
		7565	In a RC task, received data unmatched.	Software operation error occurred	(1)Reset the alarm, and then try again. (2)If the alarm occurs again, save the CMOS.BIN in maintenance mode, and then contact your Yaskawa representative about occurrence status (operating procedure).
		7566	In a RC task, received data size over.	Software operation error occurred	(1)Reset the alarm, and then try again. (2)If the alarm occurs again, save the CMOS.BIN in maintenance mode, and then contact your Yaskawa representative about occurrence status (operating procedure).
		7567	In a RC task, receive data size zero detected.	Software operation error occurred	(1)Reset the alarm, and then try again. (2)If the alarm occurs again, save the CMOS.BIN in maintenance mode, and then contact your Yaskawa representative about occurrence status (operating procedure).
		7568	In a RC task, reply head error detected.	Software operation error occurred	(1)Reset the alarm, and then try again. (2)If the alarm occurs again, save the CMOS.BIN in maintenance mode, and then contact your Yaskawa representative about occurrence status (operating procedure).
		7569	In a RC task, reply status error detected.	Software operation error occurred	(1)Reset the alarm, and then try again. (2)If the alarm occurs again, save the CMOS.BIN in maintenance mode, and then contact your Yaskawa representative about occurrence status (operating procedure).
4730	MOTION RANGE LIMIT OVER		Sub Code: Control group	Setting error	(1)Check the following settings. ·Perform the teaching again to correct positions for manipulators so that the step where the alarm occurred is within the motion range.
4731	DEST MOTION RANGE LIMIT OVER		Sub Code: Control group	Setting error	(1)Check the following settings. ·Check the position setting for the step (move instruction) where the alarm occurred.
4822	HARD WIRE BASE BLOCK ERROR			Connection failure	(1)Reset the alarm (2)If the alarm occurs again, replace controller. Save the CMOS.BIN before replace controller to be safe.

Alarm Number	Alarm Name	Sub Code	Meaning	Cause	Remedy
				Servo control board failure	(1)Reset the alarm (2)If the alarm occurs again, replace controller. Save the CMOS.BIN before replace controller to be safe.
				Software operation error occurred	(1)Reset the alarm. (2)If the alarm occurs again, save the CMOS.BIN in maintenance mode, and then contact your Yaskawa representative about occurrence status (operating procedure).
4823	HARD WIRE BASE ENABLE ERROR			Connection failure	(1)Reset the alarm (2)If the alarm occurs again, replace controller. Save the CMOS.BIN before replace controller to be safe.
				Servo control board failure	(1)Reset the alarm (2)If the alarm occurs again, replace controller. Save the CMOS.BIN before replace controller to be safe.
				Software operation error occurred	(1)Reset the alarm. (2)If the alarm occurs again, save the CMOS.BIN in maintenance mode, and then contact your Yaskawa representative about occurrence status (operating procedure).
4825	BASE ENABLE ERROR			Connection failure	(1)Reset the alarm (2)If the alarm occurs again, replace controller. Save the CMOS.BIN before replace controller to be safe.
				Servo control board failure	(1)Reset the alarm (2)If the alarm occurs again, replace controller. Save the CMOS.BIN before replace controller to be safe.
				Software operation error occurred	(1)Reset the alarm. (2)If the alarm occurs again, save the CMOS.BIN in maintenance mode, and then contact your Yaskawa representative about occurrence status (operating procedure).
4826	POWER RELAY ERROR			Connection failure	(1)Reset the alarm (2)If the alarm occurs again, replace controller. Save the CMOS.BIN before replace controller to be safe.
				Servo control board failure	(1)Reset the alarm (2)If the alarm occurs again, replace controller. Save the CMOS.BIN before replace controller to be safe.
				Power relay failure	(1)Reset the alarm (2)If the alarm occurs again, replace controller. Save the CMOS.BIN before replace controller to be safe.
4830	PP E-STOP SIGNAL ERROR			Connection failure	(1)Reset the alarm. (2)If the alarm occurs again, save the CMOS.BIN in maintenance mode, and then contact your Yaskawa representative about occurrence status (operating procedure).

Alarm Number	Alarm Name	Sub Code	Meaning	Cause	Remedy
				programming pendant failure	(1)Reset the alarm. (2)Still the alarm occurs again after confirming the connection or insertion status, execute the following operation. ·Replacement of the programming pendant
				Machine safety board failure	(1)Reset the alarm. (2)If the alarm occurs again, save the CMOS.BIN in maintenance mode, and then contact your Yaskawa representative about occurrence status (operating procedure).
4831	PANEL E-STOP SIGNAL ERROR			Machine safety board failure	(1)Reset the alarm. (2)If the alarm occurs again, save the CMOS.BIN in maintenance mode, and then contact your Yaskawa representative about occurrence status (operating procedure).
				Connection failure	(1)Reset the alarm. (2)If the alarm occurs again, save the CMOS.BIN in maintenance mode, and then contact your Yaskawa representative about occurrence status (operating procedure).
4832	EXT E-STOP SIGNAL ERROR			Connection failure	(1)Reset the alarm. (2)If the alarm occurs again, execute the following operation. ·Replacement of the connection cable
				Hardware failure	(1)Reset the alarm. (2)If the alarm occurs again, execute the following operation. ·Replacement of the external emergency stop button or the corresponding parts. (2)If the alarm occurs again, save the CMOS.BIN in maintenance mode, and then contact your Yaskawa representative about occurrence status (operating procedure).
4833	ENABLE SW SIGNAL ERROR			Enable signal unmatched error	(1)Reset the alarm. (2)Check the followings. ·There are two point of contact enable switch, and only one might be turned ON by how to squeeze. Moreover, only one might be turned ON when putting it on the place where it is not a plane on the knee etc.
				Connection failure	(1)Reset the alarm. (2)If the alarm occurs again, execute the following operation. ·Replacement of the programming pendant
				programming pendant failure	(1)Reset the alarm. (2)If the alarm occurs again, execute the following operation. ·Replacement of programming pendant
				Machine safety board failure	(1)Reset the alarm. (2)If the alarm occurs again, save the CMOS.BIN in maintenance mode, and then contact your Yaskawa representative about occurrence status (operating procedure).

Alarm Number	Alarm Name	Sub Code	Meaning	Cause	Remedy
4834	SAFTY PLUG SIGNAL ERROR			Connection failure	(1)Reset the alarm. (2)If the alarm occurs again, execute the following operation. ·Replacement of connection cable
				Hardware failure	(1)Reset the alarm. (2)If the alarm occurs again, execute the following operation. ·Replacement of the switch used for safeguarding signal or the corresponding parts.
				Hardware failure	(1)Reset the alarm. (2)If the alarm occurs again, execute the following operation. ·Replacement of the switch used for protection stop signal or the corresponding parts.
4836	OVERRUN SIGNAL ERROR (OT1)		Sub Code: Control group	Machine safety board failure	(1)Reset the alarm. (2)If the alarm occurs again, save the CMOS.BIN in maintenance mode, and then contact your Yaskawa representative about occurrence status (operating procedure).
				Enable signal unmatched error	(1)Reset the alarm. (2)If the alarm occurs again, confirm the followings. ·Select "OVERRUN & S-SENSOR"from "ROBOT" menu to display OVERRUN & S-SENSOR window. The alarm can be released on this window.
				Connection failure	(1)Reset the alarm. (2)If the alarm occurs again, execute the following operation. ·Replacement of the connection cable
4837	OVERRUN SIGNEAL ERROR (OT2)		Sub Code: Control group	Hardware failure	(1)Reset the alarm. (2)If the alarm occurs after the replacement of the machine safety module, execute the following operation. ·Replacement of the limit switch or corresponding parts.
				Machine safety board failure	(1)Reset the alarm. (2)If the alarm occurs again, save the CMOS.BIN in maintenance mode, and then contact your Yaskawa representative about occurrence status (operating procedure).
				Enable signal unmatched error	(1)Reset the alarm. (2)If the alarm occurs again, confirm the followings. ·Select "OVERRUN & S-SENSOR"from "ROBOT" menu to display OVERRUN & S-SENSOR window. The alarm can be released on this window.
				Connection failure	(1)Reset the alarm. (2)If the alarm occurs again, confirm the following. ·Replacement of the connection cable
				Hardware failure	(1)Reset the alarm. (2)If the alarm occurs after the replacement of the machine safety module, execute the following operation. ·Replacement of the limit switch or corresponding parts.

Alarm Number	Alarm Name	Sub Code	Meaning	Cause	Remedy
				Machine safety board failure	(1)Reset the alarm. (2)If the alarm occurs again, save the CMOS.BIN in maintenance mode, and then contact your Yaskawa representative about occurrence status (operating procedure).
4838	OVERRUN DETECT		Sub Code: Control group	Overrun limit switch released	(1)Reset the alarm. (2)If the alarm occurs again, confirm the followings. ·Select "OVERRUN & S-SENSOR"from "ROBOT" menu to display OVERRUN & S-SENSOR window. The alarm can be released on this window.
				Connection failure	(1)Reset the alarm. (2)If the alarm occurs again, confirm the following. ·Replacement of the connection cable
				Hardware failure	(1)Reset the alarm. (2)If the alarm occurs after the replacement of the machine safety board, execute the following operation. ·Replacement of the limit switch or corresponding parts.
				Machine safety board failure	(1)Reset the alarm. (2)If the alarm occurs again, save the CMOS.BIN in maintenance mode, and then contact your Yaskawa representative about occurrence status (operating procedure).
4839	MODE SIGNAL CUT			Dummy connector not inserted	Insert the dummy connector.
				Connection failure	(1)Reset the alarm. (2)If the alarm occurs after above mentioned operation, execute the following operation. ·Confirm the looseness of the connectors connecting the programming pendant and the cable. ·Replace the programming pendant cable.
				programming pendant failure	(1)Reset the alarm. (2)If the alarm occurs again, execute the following operation. ·Replacement of the programming pendant
				Servo control board failure	(1)Reset the alarm. (2)If the alarm occurs again, save the CMOS.BIN in maintenance mode, and then contact your Yaskawa representative about occurrence status (operating procedure).
4840	INTERLOCK CONNECTOR IS USED		Sub Code: Servo control board from which errors are detected. 0000_0001 SV#1 0000_0010 SV#2	Insert connector	(1)Reset the alarm. (2)Disconnect the connector for releasing the manual brake

Alarm Number	Alarm Name	Sub Code	Meaning	Cause	Remedy
				Servo control board failure	(1)Reset the alarm. (2)If the alarm occurs again, save the CMOS.BIN in maintenance mode, and then contact your Yaskawa representative about occurrence status (operating procedure).
4901	CUBE/AXIS INTERFERENCE		Sub Code; Group, axis, and interference area number	Setting error	(1)Check the following settings. ·Perform the teaching again to correct positions for manipulators so that the step where the alarm occurred is out of interference area. ·Change the settings for interference area.
4902	CUBE INTERFERENCE (CONTROL POINT MONITOR)		Sub Code: Control group & Area number	Setting error	(1)Check the following settings. ·Perform the teaching again to correct positions for manipulators so that the step where the alarm occurred is out of interference area. ·Change the settings for interference area.
4903	CUBE INTERFERENCE (WHOLE MONITOR)		Sub Code: Control group & Interference axis & Area number	Setting error	(1)Check the following settings. ·Perform the teaching again to correct positions for manipulators so that the step where the alarm occurred is out of interference area. ·Change the settings for interference area.
4904	CUBE INTERFERENCE AREA SETTING ERROR	0	Maximum number of the cube interference area exceeds the allowable range.	Setting error	(1)Reset the alarm. (2)If the alarm occurs again, save the CMOS.BIN in maintenance mode, and then contact your Yaskawa representative about occurrence status (operating procedure).
		1	The number of cube interference area whose monitoring part is "whole" exceeds the limit.	Setting error	Reduce the number of cube interference area whose monitoring part is "whole".
		2	Detect the cube whose interference area are extremely big or small.	Setting error	(1)Among the cube interference areas already values are entered, modify as follows. 1.Change the extremely big values to smaller ones. 2.Change the extremely small values to bigger ones. (2)If the alarm occurs again, save the CMOS.BIN in maintenance mode, and then contact your Yaskawa representative about occurrence status (operating procedure).
		3	Detect the cube interference area whose monitoring part is set to "whole" despite the invalid status of cube arm interference check function.	Setting error	(1)Reset the alarm. (2)If the alarm occurs just after loading the cube interference area setting function, execute the following measures. 1.Among the cube interference areas to be loaded, change the monitoring part setting from "whole" to "control point." 2.Load the changed cube interference area again. 3.If the alarm occurs again after loading the area, confirm its setting again. (3)If the alarm occurs again, save the CMOS.BIN in maintenance mode, and then contact your Yaskawa representative about occurrence status (operating procedure).
4940	MOTION COMMAND CODE ERROR (SV)			Software operation error occurred	(1)Reset the alarm. (2)If the alarm occurs again, save the CMOS.BIN in maintenance mode, and then contact your Yaskawa representative about occurrence status (operating procedure).

Alarm Number	Alarm Name	Sub Code	Meaning	Cause	Remedy
4941	CANNOT EXECUTE MOTION CMD (SV)			Software operation error occurred	(1)Reset the alarm. (2)If the alarm occurs again, save the CMOS.BIN in maintenance mode, and then contact your Yaskawa representative about occurrence status (operating procedure).
4942	AVERAGING TIME CHANGE ERROR (SV)			Software operation error occurred	(1)Reset the alarm. (2)If the alarm occurs again, save the CMOS.BIN in maintenance mode, and then contact your Yaskawa representative about occurrence status (operating procedure).
4943	AVERAGING TIME ERROR (SERVO)			Software operation error occurred	(1)Reset the alarm. (2)If the alarm occurs again, save the CMOS.BIN in maintenance mode, and then contact your Yaskawa representative about occurrence status (operating procedure).
4944	POSITION LOOP GAIN ERROR (SV)			Software operation error occurred	(1)Reset the alarm. (2)If the alarm occurs again, save the CMOS.BIN in maintenance mode, and then contact your Yaskawa representative about occurrence status (operating procedure).
4945	MOTION COMMAND DATA ERROR (SV)			Software operation error occurred	(1)Reset the alarm. (2)If the alarm occurs again, save the CMOS.BIN in maintenance mode, and then contact your Yaskawa representative about occurrence status (operating procedure).
4946	PG POWER ON INCOMPLETE (SV)			Software operation error occurred	(1)Reset the alarm. (2)If the alarm occurs again, save the CMOS.BIN in maintenance mode, and then contact your Yaskawa representative about occurrence status (operating procedure).
4947	SERVO ON MULTIPLE REQUEST (SV)			Software operation error occurred	(1)Reset the alarm. (2)If the alarm occurs again, save the CMOS.BIN in maintenance mode, and then contact your Yaskawa representative about occurrence status (operating procedure).
4948	ENCODER ALARM (SERVO)			Software operation error occurred	(1)Reset the alarm. (2)If the alarm occurs again, save the CMOS.BIN in maintenance mode, and then contact your Yaskawa representative about occurrence status (operating procedure).
4953	ENCODER COUNTER DIFF. ERROR(SV)		Sub Code: Signifies the axis in which the alarm occurred	Connection failure	(1)Reset the alarm (2)If the alarm occurs again, check the connection and inserting state of the following cables and connectors. {Robot axis} · Cable between encoders {External axis} · Cable between encoders

Alarm Number	Alarm Name	Sub Code	Meaning	Cause	Remedy
				Servo control board failure	(1)Reset the alarm. (2)If the alarm occurs again, replace controller. Save the CMOS.BIN before replace controller to be safe.
4955	AVERAGING DATA ERROR (SERVO)			Software operation error occurred	(1)Reset the alarm. (2)If the alarm occurs again, save the CMOS.BIN in maintenance mode, and then contact your Yaskawa representative about occurrence status (operating procedure).
4956	AVERAGING SUM ERROR (SERVO)			Software operation error occurred	(1)Reset the alarm. (2)If the alarm occurs again, save the CMOS.BIN in maintenance mode, and then contact your Yaskawa representative about occurrence status (operating procedure).
4957	AVERAGING STATUS ERROR (SERVO)			Software operation error occurred	(1)Reset the alarm. (2)If the alarm occurs again, save the CMOS.BIN in maintenance mode, and then contact your Yaskawa representative about occurrence status (operating procedure).
4958	HIGH RESOLUTION PRM UNDEFINED(SV)			Software operation error occurred	(1)Reset the alarm. (2)If the alarm occurs again, save the CMOS.BIN in maintenance mode, and then contact your Yaskawa representative about occurrence status (operating procedure).
4960	BELT SNAP DETECT PRM ERROR (SV)		Sub Code: Signifies the axis in which the alarm occurred	Setting error	(1)Reset the alarm. (2)If the alarm occurs again, save the CMOS.BIN in maintenance mode, and then contact your Yaskawa representative about occurrence status (operating procedure).
4961	SERIAL ENC OSCILL DETECTED (SV)		Sub Code: Signifies the axis in which the alarm occurred	Software operation error occurred	(1)Reset the alarm. (2)If the alarm occurs again, save the CMOS.BIN in maintenance mode, and then contact your Yaskawa representative about occurrence status (operating procedure).
4962	BRAKE LOCK ERROR (SERVO)		Sub Code: Signifies the axis in which the alarm occurred	Software operation error occurred	(1)Reset the alarm. (2)If the alarm occurs again, save the CMOS.BIN in maintenance mode, and then contact your Yaskawa representative about occurrence status (operating procedure).
4963	BRAKE RELEASE ERROR (SERVO)		Sub Code: Signifies the axis in which the alarm occurred	Software operation error occurred	(1)Reset the alarm. (2)If the alarm occurs again, save the CMOS.BIN in maintenance mode, and then contact your Yaskawa representative about occurrence status (operating procedure).

Alarm Number	Alarm Name	Sub Code	Meaning	Cause	Remedy
4964	CONST.SPD MEASURE MULTI REQ (SV)		Sub Code: Signifies the axis in which the alarm occurred	Software operation error occurred	(1)Reset the alarm. (2)If the alarm occurs again, save the CMOS.BIN in maintenance mode, and then contact your Yaskawa representative about occurrence status (operating procedure).
4965	DIN SIGNAL SPECIFIC. ERROR (SV)			Setting error	Confirm the DIN signal settings.
4972	CONVTR REGENERATE OVERLOAD(SV)			Primary power supply failure	Correct the converter primary power supply.
				Setting error	Check the following settings. ·The tool information ·JOB ·Work ·The speed of JOB ·The acceleration/deceleration speed of ACC and DEC
				Connection failure	(1)Reset the alarm (2)If the alarm occurs again, replace controller. Save the CMOS.BIN before replace controller to be safe.
				Module failure (Regenerative resistor)	(1)Reset the alarm (2)If the alarm occurs again, replace controller. Save the CMOS.BIN before replace controller to be safe.
				Module failure (converter)	(1)Reset the alarm (2)If the alarm occurs again, replace controller. Save the CMOS.BIN before replace controller to be safe.
				Servo control board failure	(1)Reset the alarm (2)If the alarm occurs again, replace controller. Save the CMOS.BIN before replace controller to be safe.
4973	POSITION ERROR (COLLISION DETECT)			Setting error	Confirm the settings of the followings. ·The tool information ·Work
4980	DESTINATION PULSE LIMIT			Setting error	(1)Check the following settings. ·Check the position setting for the step (move instruction) where the alarm occurred.
4981	DEST PULSE MECHANICAL LIMIT			Setting error	(1)Check the following settings. ·Check the position setting for the step (move instruction) where the alarm occurred.

Alarm Number	Alarm Name	Sub Code	Meaning	Cause	Remedy
4982	DEST MECHANICAL INTRF			Setting error	(1)Check the following settings. ·Check the position setting for the step (move instruction) where the alarm occurred.
4983	DEST MECHANICAL INTRF			Setting error	(1)Check the following settings. ·Check the position setting for the step (move instruction) where the alarm occurred.
4984	DESTINATION SELF-INTERFERENCE			Setting error	(1)Check the following settings. ·Check the position setting for the step (move instruction) where the alarm occurred.

10 Error

10.1 Error Message

Error warns the operator not to advance to the next operation caused by a wrong operation or the access method when using the programming pendant or an external equipment (computer, PLC, etc.).

When an error occurs, confirm the content of the error then release the error.

To release the error, perform either of the following operations:

- Press [CANCEL] on programming pendant.
- Input alarm/error reset signal (system input).



An error is different from an alarm because it does not stop the robot even if it occurred while the robot was operated (during playback).



When two or more errors occur, appears in the message display area. Activate the message display area and press [SELECT] to view the list of current errors.

10.1.1 System and General Operation

Error No.	Data	Error Message	Contents
10	-	Turn OFF servo power and perform corrective action	It cannot be operated while servo power supply is ON.
20	-	Depress TEACH	Out of specified operation mode
30	-	Illegal setting for number of variables	Parameter setting error
31	-	Illegal setting for number of variable-names	
32	-	Illegal setting for number of SUB task.	
40	-	Undefined robot position variables	Position variable cannot be used.
50	-	Depress MODIFY	
60	-	Undefined points (ORG, XX, XY)	Not registered user coordinates basic 3 points (ORG, XX, XY)
70	-	Program and current tool different	The tool number registered with teaching position data does not match the tool number selected at the programing pendant.
80	-	Same position in the 3 points	
90	-	Set robot exactly to taught position	
100	-	On overrun recovery status	
110	-	Turn ON servo power	
120	-	Set to PLAY mode	
130	-	No start using external signal	
140	-	No start using P.P.	
150	-	TEACH-LOCK mode ON	
160	-	ENABLE LED ON	
170	-	Servo OFF signal ON	
180	-	TEACH mode select signal ON	
190	-	Set variable number	
200	-	Defined group axis	
210	-	Undefined coordinated robots	
211	-	Cannot register between stations	
212	-	Cannot register at this combination	
220	-	Taught by other robot	
230	-	While releasing soft limit	
240	-	Undefined robot	
250	-	Defined condition No.	
260	-	Undefined file	
280	-	Lack of number of I/O points	
290	-	Cannot set same No.	
300	-	Undefined user frame	
310	-	Cannot register Master JOB	
320	-	Cannot operate CHECK-RUN	
330	-	Cannot operate MACHINE LOCK	
340	-	Cannot operate Master JOB	

Error No.	Data	Error Message	Contents
350	-	Cannot initialize	
360	-	Teach point not specified	
370	-	No SYNCRO operation	
380	-	Position not checked	Second home position was not checked.
383	-	Select joint coordinate system and perform forward operation	
390	-	Can specify servo OFF by safety relay	
400	-	Wrong specification of measure interval	
410	-	Time could not be measured	Time could not be measured for TRT function.
420	-	Incorrect number of taught points	The number of the taught points for tool calibration is incorrect.
430	-	Register start reserved JOB	
440	-	Clear data to teach at the tool because other tool is set	
450	-	Wrong JOB for measuring	
460	-	Excess time for measuring	
470	-	Calibrated at another file	
480	-	Calibrated at another robot combination	
490	-	Cannot calibrate at this combination	
500	-	Undefined robot calibration data	
510	-	Undefined axis	
520	-	Cannot select two coordinated combination	
530	-	Start reservation mode	
540	-	Not start reservation mode	
550	-	Start reserved JOB change prohibit is set	
560	-	Cannot teach position while soft limit released	
590	-	Register group axis combination	[SYNCHRO] was pressed for coordinated job which was not registered as group.
600	-	Out of setting data range	
610	-	Cannot use the user coordinate	
620	-	Select JOB (robot)	
630	-	Not completed to load original tool file	
640	-	Not specified Tool File	
650	-	Incorrect measured data	
660	-	Wrong data type of position variable	
670	-	Enter path number	
680	-	Defined data	
	XXX		File no.
690	-	Illegal path number	
700	-	Wrong CMOS memory board type	
710	-	Canceled pelletizing shift value	
720	-	Defined name	

Error No.	Data	Error Message	Contents
721	-	It is already registered for IN/OUT signal name.	
722	-	It is already registered for Variable name.	
723	-	It is already registered for Local variable name.	
724	-	The existing names cannot be overwritten	
730	-	Undefined Name Position file	
750	-	This name cannot be defined	
760	-	Error in start condition set	
770	-	During robot or station operation	
790	-	FWD/BWD don't work in the handle operation	
810	-	Servo power supply is limited	
820	-	Modification range over	
830	-	Cannot move while modifying speed	
840	-	Unregistered key	
850	-	Cannot register instruction	
860	-	Please release key registration mode	
870	-	This key cannot be allocated	
880	-	Same relay cannot be set	
890	-	This key has already been registered. Cannot register them once	
900	-	Relay No. not set	
910	-	Cannot be registered because job control group not same	
920	-	Cannot modify this setting	
930	-	Undefined conveyor calibration data	
960	-	I/O axis mode requesting	
971	-	ERRCPU signal error	

FS100 Controller

10 Error
10.1 Error Message**10.1.2 Editing**

Error No.	Data	Error Message	Contents
1010	-	EDIT LOCK mode	
1020	-	Enter correct value	
1030	-	Unauthorized ID No.	
1050	-	Enter correct date	
1060	-	Enter correct clock	
1070	-	Enter an ID number in 4-8 figures	
1080	-	Negative value can't be set	
1090	-	Enter correct value(START-END signal no)	

10.1.3 Job Defined Data

Error No.	Data	Error Message	Contents
2010	-	Incorrect character	
2020	-	Name not entered	
2030	-	Undefined JOB name	
2040	-	Defined JOB name	
2050	-	Address not found	
2060	-	Select master	
2070	-	Set robot exactly to taught position	
2080	-	Press INSERT or MODIFY	
2090	-	Only modifying move instruction possible	
2100	-	JOB cannot be edited.	
2110	-	Over soft limit	
2111	-	Over soft limit. Adjust center position or pulse width.	
2111	-	Cannot insert/alter/delete with servo OFF	
2130	-	Only modifying move instruction possible	
2140	-	Must press ENABLE to modify	
2150	-	Inserting is not possible from this point	
2160	-	Cannot modify or delete this position	
2170	-	Press INSERT to record same step as previous step	
2180	-	Cannot insert data	
2190	-	Cannot delete data	
2200	-	Cannot modify data	
2210	-	Illegal data setting	
2220	-	Display edit instruction	
2230	-	Illegal instruction equation	
2240	-	Excessive instruction equation	
2250	-	Unmatched number of parentheses in equation	
2260	-	Wrong group axis selection	
2270	-	Cannot insert any more instruction in JOB	
2280	*	JOB memory is full	
	1		Lack of position file memories
	2		Lack of JOB registering memories
	3		Lack of instruction file memories
	4		Lack of memory pool
2290	-	Undefined master JOB	

Error No.	Data	Error Message	Contents
2291	*	Undefined SUB Master JOB	
	1		Sub-master 1
	2		Sub-master 2
	3		Sub-master 3
	4		Sub-master 4
	5		Sub-master 5
2292	-	Undefined MASTER START JOB	
2293	*	Undefined SUB START JOB	
	1		Sub-master 1
	2		Sub-master 2
	3		Sub-master 3
	4		Sub-master 4
	5		Sub-master 5
2300	-	Cannot teach JOB without group-axis specification	
2310	*	Same label exists	
	XXX		Line no.
2320	-	Cannot create coordinated JOB	
2330	-	Cannot edit coordinated instruction	
2350	-	Pasted data not found	
2340	-	Editing data not found	
2360	-	Cannot create editing area	
2370	-	Cannot cut/copy NOP and END instructions	
2380	-	Wrong JOB selection	
2390	-	Wrong group axis selection	
2400	-	Cannot move in cut & paste editing	
2410	-	When variable is used for speed setting, perform a line-edit	
2420	-	When variable is used for teach setting, perform a line-edit	
2430	-	Reverse data not found	
2450	-	Relative JOB not permitted	
2460	-	Specified JOB is already converted	
2470	-	Wrong JOB type	
2480	-	Wrong JOB coordinates setting	
2490	-	Execute FWD/BWD operation once	
2500	-	Cannot convert the JOB	
2501	-	Cannot convert positions as macro arguments	
2510	-	Cannot correct position in the JOB	
2520	-	Enter JOB name	
2530	-	Illegal step number	
2540	-	Enter step number	
2550	-	Duplicated step number	

Error No.	Data	Error Message	Contents
2551	-	Duplicated line number	
2560	-	Cannot correct steps of position variables and REFP	
2570	-	The step does not contain speed	
2580	-	The step dose not contain PL/CONT	
2590	-	Soft limit range over	
2600	-	Cannot teach position in concurrent JOB	
2610	-	Wrong JOB kind	
2620	-	Cannot correct play speed in the JOB	
2630	-	Conveyor position not reset	
2640	-	Incorrect JOB name	
2650	-	Defined JOB name	
2660	-	Register MOVL after circular block	
2670	-	Undefined target JOB	
2690	-	Defined same kind JOB	
2710	-	Relative job can't be shifted with pulse type	
2720	-	Cannot correct position variables	
2730	-	Cannot use robot macro JOB	
2740	-	Cannot use concurrent macro JOB	
2750	-	Cannot use JOB with group-axis specification	
2760	-	Cannot insert/modify/delete for group axis detachment	
2761	-	Cannot insert/modify/delete for axis detachment	
2780	-	Arithmetic error	
2790	-	Step exceeding operation range.	

10.1.4 External Memory Equipment

Error No.	Data	Error Message	Contents
3021	-	CompactFlash not inserted into CompactFlash slot(PP)	
3022	-	USB media not inserted	
3040	-	File not saved on the media	
3050	-	File saved on the media	
3060	-	Out of memory on the media	
3070	-	Number of files on the media	
3080	-	I/O error on the media	
3090	-*	Transmission error with the media	
	1		Framing error
	2		Overrun error
	3		Parity error
	4		Data code error
	5		Data read error
	6		Data write error
	7		Data time out
	8		Serial I/O error
9		Error other than described above	
3100	-	Total checksum error	
3110	-	Syntax error	
3120	*	HEX code error	
	1		Specification error of data decode
	2		Specification error of EOF record
	3		Record type error
4		Total check error of record	
3130	-	Verify error	
3140	-	Wrong pseudo instruction	
3150	*	Concurrent I/O record error	
	1		Format error
	2		Ladder program is too long
	3		Exceed the range of the data
	4		Specification error of channel No.
	5		Specification error of relay No.
6		Timer value error	
3150	7		Specification error of timer No
3160	-	Cannot load illegal system data	
3170	*	Condition file data error	
	1		Format error
	2		Specified file No. is omitted
	3		Specified tool No. is omitted
4		User file is not registered.	
3180	-	Concurrent I/O data transmission error	

Error No.	Data	Error Message	Contents
3190	*	Error in JOB data record	
	1		Record on the number of position data (NPOS) is wrong for the format.
	2		Record on the user coordinate No. (USER) is wrong for the format.
	3		Record on the tool No. (TOOL) is wrong for the format.
	4		Record on the position data section is wrong for the format.
	5		Record on the robot type of XYZ data (RCONF) is wrong for the format.
	6		Date (DATE) record is wrong for the format.
	7		Comment (COMM) record is wrong for the format.
	8		Record on the JOB attribute data (ATTR) is wrong for the format.
	9		Control group (GROUP) record is wrong for the format.
	10		Local variable (LVAR) record is wrong for the format.
	11		JOB argument (JARGS) record is wrong for the format.
	12		Record on the teaching coordinates for relative job (FRAME) is wrong for the format.
13		Position data coordinates do not match relative job coordinates.	
3200	-	NOP or END instruction not found	
3210	-	Position No. storage area not found	
3220	*	Syntax error in instruction data	
	2		Interior control error
	3		Undefined instruction/tag
	4		Instruction/tag shortage
	5		Disuse instruction/tag
	6		Sub instruction

Error No.	Data	Error Message	Contents
3220	7		No instruction
	8		Invalid instruction
	9		Invalid tag
	10		Invalid character
	11		Undefined intermediate code
	12		Intermediate code shortage
	13		Syntax stack overflow
	14		Syntax stack underflow
	15		Array type tag uncompleted Tag [ARRAY]
	16		Element type tag uncompleted Tag [ELEMENT]
	17		Macro JOB unregistered
	18		Input format error
	19		Data size over
	20		MIN value over
	21		MAX value over
	22		Operation expression error
	23		Job call argument setting error
	24		Macro job call argument setting error
	25		Position vector setting error
	26		System error
	27		Soft key designate error
	28		Numerical input buffer overflow
	29		Real type data precision error
	30		Element format error
	35		BOOL TYPE data error
	36		CHAR data error
	37		BYTETYPE, BINARY / HEXADECIMAL BYTE TYPE data error
	38		INTEGER TYPE, DECIMAL WORD TYPE data error
	39		BINARY/HEXADECIMAL WORD TYPE data error
	40		DOUBLE PRECISION INTEGER TYPE, DECIMAL DWORD TYPE data error
	41		BINARY/HEXADECIMAL WORD TYPE data error
	42		REAL TYPE data error
43		LADDER SPECIAL TYPE data error	
44		JCL text	
45		Invalid text	
46		LABEL NAME data error	
47		JOB NAME data error	
48		STRING data error	
49		COMMENT data error	
58		Invalid instruction/tag detection	
3230	-	Syntax not matched	

Error No.	Data	Error Message	Contents
3240	-	Undefined application	
3250	-	Cannot load this file	
3260	-	Excess input data	
3270	-	Cannot verify this file	
3290	-	Serial port not defined	
3300	-	Serial port being used	
3310	-	Protocol being used	
3350	-	Not enough memory	
3360	-	Invalid folder	
3370	-	Incorrect folder name	
3380	-	Drive not ready	
3390	-	File not found	
3400	-	File already exists on the media	
3410	-	Out of memory on the media	
3420	-	Max number of files has been reached	
3430	-	I/O error on the drive	
3440	-	Wrong media type	
3450	-	Cannot load macro JOB at current security mode	Load in management mode.
3460	*	Cannot backup the media	
	1		Insufficient Compact Flash memory.
	2		Not accessible to Compact Flash.
3470	-	Database not found	
3480	-	Database access error	
3490	-	Same database exists	
3500	-	Check the media insertion	
3501	-	Check the media insertion	
3510	-	Cannot delete folder. Check attribute and inside file	
3520	-	Same folder exists	
3530	-	Cannot load at current security mode	
3540	-	CMOS not compatible	
3550	-	Under automatic backup operation. Operate after the backup is completed.	
3551	-	Under automatic backup operation. Operate "SORT FILE" after the backup is completed.	
3560	-	Failed in sorting backup file	
3570	-	Actuator data transmission error	
3580	-	Under backup file access. Operate after the access is completed.	
3581	-	Under backup file access. Operate "SORT FILE" after the access is completed.	

FS100 Controller

10 Error
10.1 Error Message

Error No.	Data	Error Message	Contents
3600	-	system configuration data not matched	
3610	-	Excessive path	
3620	-	Excess folders	

10.1.5 Concurrent I/O

Error No.	Data	Error Message	Contents
4010	*	Illegal relay No.	
	XXX		Line no.
4020	-	Illegal block No.	
4030	*	Illegal instruction	
	XXX		Line no.
4040	*	Relay/register No. duplicated in OUT/ GOUT or arithmetic instruction	Multiple outputs are instructed to the relay or register.
	XXX		Line no.
4050	*	The relay is not used	
	XXX		Line no.
4060	*	Excess STR[-NOT] instructions	
	XXX		Line no.
4070	*	Excess AND [OR] STR instructions	
	XXX		Line no.
4080	*	Syntax error in CRT instructions	
	XXX		Line no.
4090	*	Enter STR [-NOT] at head of block	Need STR [-NOT]
	XXX		Line no.
4100	-	Relay No. duplicated in TMR and CNT	
4110	-	Excessive ladder scan-time	
4120	-	Concurrent I/O memory is full	Exceeds memory capacity (10000 steps)
4130	-	END instruction not found	END instruction not found
4140	-	Wrong ladder program	Position and number of PART instruction are wrong.
4150	*	Wrong use of GSTR, GOUT commands	GSTR and GOUT is not used together.
	XXX		Line no.
4160	-	Cannot edit system section	
4170	-	Cannot modify/delete	
4180	-	Depress INSERT/MODIFY/DELETE keys	
4190	-	Ladder program not found	
4200	-	Cannot specify system variables(\$)	
4210	-	Cannot edit line	
4220	-	Excess TMR/CNT or arithmetic instructions	More than 100 TMR, CNT or arithmetic instruction used
4230	-	Syntax error in TMR/CNT instructions	

10.1.6 Maintenance Mode

Error No.	Data	Error Message	Contents
8010	-	Too many axes	
8011	-	Choose the input of overrun	
8020	-	Too many I/O points	
8030	-	Too many boards (DEVICENET)	
8033	-	Too many boards	
8034	-	Too many channels	
8035	-	Invalid configuration	
8040	-	Memory error (ControlNet output condition)	
8041	-	Memory error (UNIWIRES CONNECT DAT)	
8042	-	Memory error(IP Network Configuration data)	
8050	-	Robot model is not registered	
8051	-	Select model	
8060	-	Cannot get UNIWIRES connection data	
8070	-	DHCP is already set to use for another item	
8071	-	DNS is already set to use for another item	
8072	-	DHCP is not set to use	
8073	-	DNS is not set to use	
8074	-	Device Information not found	
8075	-	Unable to accept same type of boards simultaneously	
8076	-	Ethernet is being used by other function.	
8080	-	Non support function	
8205	-	ENABLE Unit over	
8206	-	FLASH access error	
8210	-	IO module configuration is not modified	
8211	-	OPTION, BOARD or MODULE SETUP is not completed.	
8212	-	Cannot change setting (Function conflict)	
8213	-	Check EXTERNAL IO setup	

10.2 Particular Error Message

Apart from ordinary alarms or errors, some may display an error box message on the programming pendant. This message is displayed, when the system of the programming pendant becomes unauthorized.

10.2.1 Message

10.2.1.1 Fatal Error

This message is displayed when the fatal error occurs.

The message is “Fatal application Error” although the content of the message box varies depending on the occurrence status.

The programming pendant becomes either of following states

1. The window becomes inoperable.
2. The window disappears and blue background appears.

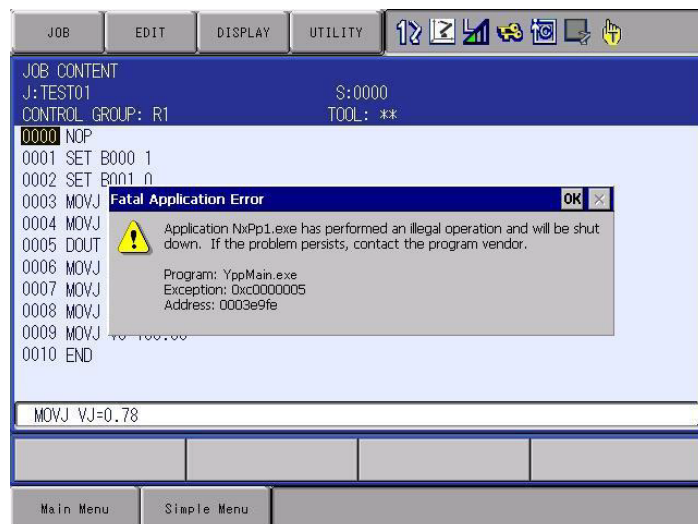

10.2.1.2 Application Transaction Error

This message is displayed when the system or the software of the programming pendant becomes unauthorized due to unexpected transaction or failure in software transaction, etc.

The message in the message box varies depending on the occurrence status.

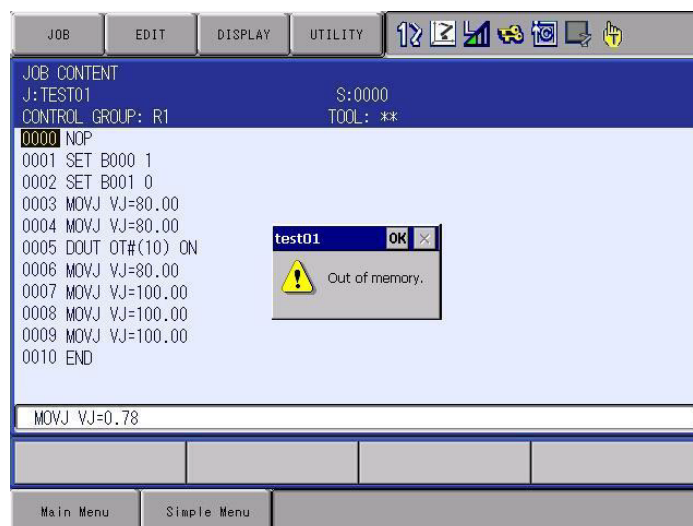

Followings are the messages possible to occur.

Message	Meaning
syntax error	There is an unauthorized part in internal processing description.
expression too complex (stack overflow)	Internal stack has overflowed.
function nesting depth exceeded	Nesting of internal processing is unauthorized.
bad radix	The cardinal number used is unauthorized.
divide by 0	Memory is running out.
out of memory	Memory is insufficient.
argument list does not match a function	The internal processing of the pendant program is unauthorized.
register is not available	Specified an unavailable system data.

The programming pendant becomes either of following states

1. The window becomes inoperable.
2. Press {OK} button to disappear the message box and it becomes operable.

10.2.1.3 Other Errors

Other errors than mentioned above, some can trigger the message box.

10.2.2 When the Error is Indicated

10.2.2.1 Fatal Error

Programming pendant becomes inoperable when this message appears. Please restart the system.

10.2.2.2 Application Transaction Error

It is possible to keep the operation after pressing {OK} button to disappear the message box. However, in this case, the system might be instable. Please restart the system if the window becomes inoperable.

10.2.2.3 Other Errors

Most of the cases when an error occurs, it is possible to keep the operation after pressing {OK} button to disappear the message box. Please restart the system if the window becomes inoperable.

Sometimes the message appears due to a specific operation although unstable state of the programming pendant is the main cause of the error in most cases.

If the pendant becomes inoperable after the message due to a specific operation invariably, please report the displayed message to your Yaskawa representative.

11 LED Indicator on Each Circuit Board

Before the check of LED indicator

In principle, the door must not be opened to prevent electric shock while power is ON. However, open the door with extreme care only if it is required to check the LED display on each circuit board for maintenance.



WARNING

- To perform this operation, it is required to open the door of the control box while power is ON.
- A heavy current (200V_{AC}) flows inside the control box. Do not touch the internal unit.

Failure to observe this warning may result in electric shock.

- Close the door as soon as the maintenance work such as LED check is completed.

Failure to observe this warning may result in electric shock.



WARNING

- Close the door as soon as the maintenance work is completed.

Failure to observe this warning may result in electric shock.

11.1 6 LED-Spot Indicator on the Main CPU Circuit Board (CPU201R)

CPU201R board shows its operation status with 6 LED-spot indicator.

Indication	LED Color	Board Status when LED is lit
SV-ON	Green	While the SERVO power is turned ON.
RUN	Green	While in operation
ALM-1	Red	Occurrence of a major error
ALM-2	Red	Occurrence of a minor error
BAT	Red	Battery alarm
ERR	Red	Error

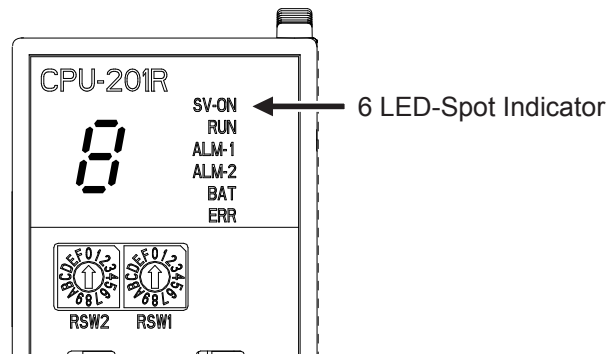

11.2 7-Segment LED Indicator on the Main CPU Circuit Board (CPU201R)

CPU201R board indicates its start-up status and error causes with 7-segment LED indicator.

Status	7-Segment LED Indicator
Immediately after the power is turned ON	All 7-SEG indicators light up. (‘8’ + ‘.’ light up.)
During the start-up process	Count up from ‘0’ toward ‘d’ or ‘P’
Online normal start-up	‘d’ + ‘.’ blink every one second
Maintenance mode start-up	‘F’ + ‘.’ blink every one second
PP/SWP unconnected	‘P’ + ‘.’ blink every one second
ERR	The error cause and the address where the error has occurred are indicated.

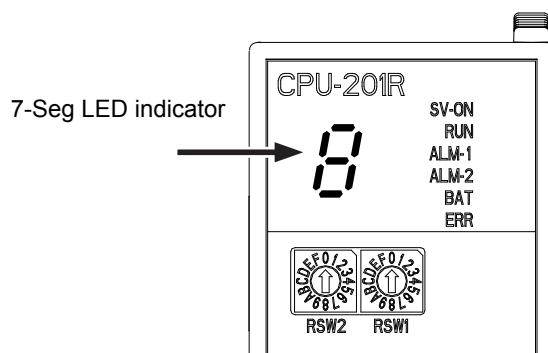

Error indication spec.:

Repeat of [-] → [F] → [0] → [2] → [0] → [0] → (Error Cause)

[.] → [-] → [0] → [0] → [0] → [0] → [F] → [F] → [0] → [4]

(Address of occurrence)

11.2.1 Status of 7-Segment LED Indicator at Error Occurrence

Error cause indication	Meaning
F0100	Critical Input
F0200	Machine Check
F0300	Data Storage
F0400	Instruction Storage
F0600	Alignment
F0700	Program
F0800	Floating Point Unavailable
F0900	Watchdog Timer Error (no address indication)
F0930	CPU Hung Up Error (no address indication)
F0a00	Auxiliary Processor Unavailable
F0c00	Fixed Interval Timer
F0d00	Watchdog Timer
F0e00	Data TLB Error
F0f00	Instruction TLB Error
F1000	Debug Exception
F1100	CPU Signal Process Engine
F1200	Floating Point Data
F1300	Floating Point Data Round
F1400	Performance Monitor

11.2.2 Status of 7-Segment LED Indicator at Control Power Start-up (one digit)

Error	Status
1	The system program has started.
2	Starts verifying the existence of other circuit boards. (Verifies the start-up of the booting program.)
3	Starts the system program transmission.
4	Sends the request of the system program start-up.
5	Starts verifying the existence of other circuit boards. (Verifies the start-up of the system program.)
6	Acquires hardware information, etc. of other circuit boards. (Verifies the IO board status, SERVO IF, and so on.)
7	Starts the CMOS data transmission.
8	Sends the pre-online request.
9	Waits for MIII communication synchronization.
A	
b	Sends the start-up request of on-line system.
C	The on-line system has started. (Starts up the initialization task.)
d	Processes of the system setup completion. (Servo ON enabled)
E	Alarm occurs at the system setup.
F	The maintenance mode is starting up.
P	The system setup PP/SWP unconnected.

11.2.3 Status of 7-Segment LED Indicator at Hardware Error Occurrence

When the hardware error is detected during the operation, the error is indicated with 4-digit numbers with the letter [H] at its head.

Indication spec.:

Repeat of [H] → [0] → [0] → [0] → [1] → [.]

Alarm No.	
H0001	MAC address error
H0002	Power lost error when start-up
H0003	Watchdog error when start-up
H0004	Interrupt clear impossible
H0005	Initialization of SERVO communication error

Turn the power supply OFF and ON again when the above mentioned numbered error is indicated by the 7-Segment.

Replacement of the controller is required if the error occurs again.

11.2.4 Status of 7-Segment LED Indicator at Alarm Occurrence

Only when the PP is not connected the FS100, the alarm number is indicated with 4-digit numbers with the letter [A] at its head.

If more than one alarm occurred, the first alarm numbers indicated.

Note that the number of the major alarm is indicated if major and minor alarms occurred at a time.

Indication spec.: when Alarm 1200 is occurred

Repeat of [-] → [A] → [1] → [2] → [0] → [0]

11.3 7 SEG-LED Indicator on Machine Safety Board (SF2300)

SF2300 board indicates its operation status with LED indicator.

Indication	LED Color	Board Status when LED is lit
PWR	Green	When the control power is turned ON.
ALM	Red	Error is being detected
HWBB1	Green	CH1 side HWBB is in operation
HWBB2	Green	CH2 side HWBB is in operation

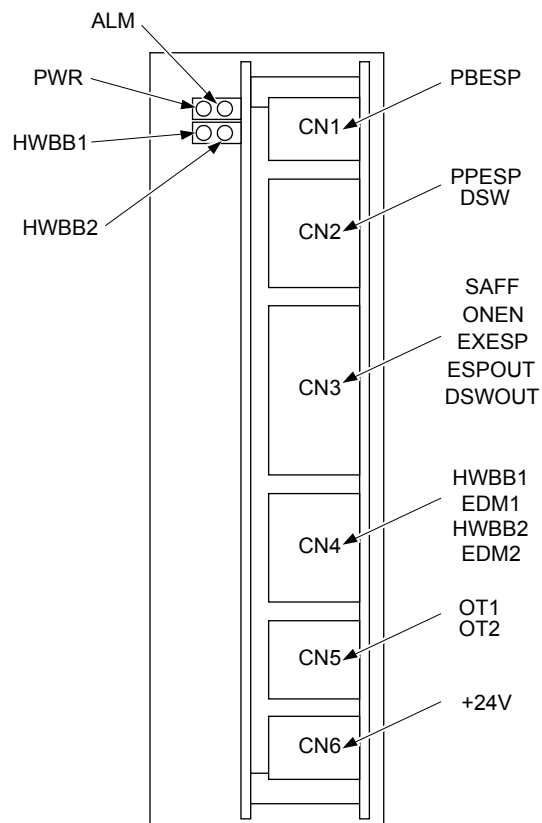





































11.4 7 SEG-LED Indicator on SERVO Control Board (IFM)

IFM board indicates its start-up status and error causes with 6 LED-spot indicator.















































Status	6 LED-spot Indicator
Immediately after the power is turned ON	“ERR” is lit
During the start-up process	Green LED are lit in sequentially. Refer to <i>section 11.4.2</i> .
Online normal start-up	“LNK2” blinks every one second
Alarm occurrence in the main CPU and SERVO control board communication system	The error cause is indicated. Refer to <i>section 11.4.1</i> .
Normal alarms other than alarms described above	“ERR” is lit.
Fatal alarm occurrence	The error cause and the address where the error has occurred are indicated.

11.4.1 LED Indicator at Alarm Occurrence in the Main CPU and SERVO Control Board Communication System

Small-sized RC SERVO CPU Board LED Status	Status
[Blink] RDY   ERR   CN   CMERR [ON]  LNK1   LNK2 	MIII send incompletion
[Blink] RDY   ERR  [Blink] CN   CMERR [ON]  LNK1   LNK2 	Receive WDG inconsistency
[Blink] RDY   ERR   CN   CMERR [ON] [Blink] LNK1   LNK2 	MIII status error
 RDY   ERR  [Blink] CN   CMERR [ON] [Blink] LNK1   LNK2 	Power lost detected by way of JL077

“Blink”: light up for 3 second then light OFF for 1 second.

11.4.2 LED Indicator During the Start-up Process

LED Status	Meaning
OFF RDY  ERR <input checked="" type="checkbox"/> ON OFF CN   CMERR <input type="checkbox"/> OFF OFF LNK1   LNK2 <input type="checkbox"/> OFF	Power supply is turned ON
OFF RDY   ERR <input type="checkbox"/> OFF OFF CN   CMERR <input type="checkbox"/> OFF OFF LNK1   LNK2 <input type="checkbox"/> OFF	Starts up boot program
ON RDY   ERR <input type="checkbox"/> OFF OFF CN   CMERR <input type="checkbox"/> OFF OFF LNK1   LNK2 <input type="checkbox"/> OFF	Starts up boot system (Completes initialization)
ON RDY   ERR <input type="checkbox"/> OFF ON CN   CMERR <input type="checkbox"/> OFF OFF LNK1   LNK2 <input type="checkbox"/> OFF	Completes the preparation for receiving the system program
ON RDY   ERR <input type="checkbox"/> OFF ON CN   CMERR <input type="checkbox"/> OFF ON LNK1   LNK2 <input type="checkbox"/> OFF	Starts up the system program has (Starts up each hardware initialization)
ON RDY   ERR <input type="checkbox"/> OFF ON CN   CMERR <input type="checkbox"/> OFF ON LNK1   LNK2 <input checked="" type="checkbox"/> ON	Starts up the SERVO system (Starts up each SERVO part initialization)
RDY   ERR <input type="checkbox"/> OFF CN   CMERR <input type="checkbox"/> OFF LNK1   LNK2 <input checked="" type="checkbox"/> ON	Starts up pre-online processes (LNK2 blinks at 0.3 sec intervals)
RDY   ERR <input type="checkbox"/> OFF CN   CMERR <input type="checkbox"/> OFF LNK1   LNK2 <input checked="" type="checkbox"/> ON	FS100 setup competed (SERVO ON enabled) (LNK2 blinks at 1 sec intervals)

FS100

MAINTENANCE MANUAL

HEAD OFFICE

2-1 Kurosakishiroishi, Yahatanishi-ku, Kitakyushu 806-0004, Japan
Phone +81-93-645-7703 Fax +81-93-645-7802

YASKAWA America Inc. (Motoman Robotics Division)
100 Automation Way, Miamisburg, OH 45342, U.S.A.
Phone +1-937-847-6200 Fax +1-937-847-6277

YASKAWA Europe GmbH (Robotics Division)
Yaskawastrasse 1, 85391 Allershausen, Germany
Phone +49-8166-90-100 Fax +49-8166-90-103

YASKAWA Nordic AB
Bredbandet 1 vån. 3 varvsholmen 392 30 Kalmar, Sweden
Phone +46-480-417-800 Fax +46-480-417-999

YASKAWA Electric (China) Co., Ltd.
22/F One Corporate Avenue No.222, Hubin Road, Huangpu District, Shanghai 200021, China
Phone +86-21-5385-2200 Fax +86-21-5385-3299

YASKAWA SHOUGANG ROBOT Co. Ltd.
No7 Yongchang North Road, Beijing E&T Development Area, China 100176
Phone +86-10-6788-2858 Fax +86-10-6788-2878

YASKAWA India Private Ltd. (Robotics Division)
#426, Udyog Vihar, Phase- IV, Gurgaon, Haryana, India
Phone +91-124-475-8500 Fax +91-124-475-8542

YASKAWA Electric Korea Co., Ltd
9F, Kyobo Securities Bldg., 26-4, Yeouido-dong, Yeongdeungpo-gu, Seoul 150-737, Korea
Phone +82-2-784-7844 Fax +82-2-784-8495

YASKAWA Electric Taiwan Corporation
12F, No.207, Sec. 3, Beishin Rd., Shindian District, New Taipei City 23143, Taiwan
Phone +886-2-8913-1333 Fax +886-2-8913-1513

YASKAWA Electric (Singapore) PTE Ltd.
151 Lorong Chuan, #04-02A, New Tech Park, Singapore 556741
Phone +65-6282-3003 Fax +65-6289-3003

YASKAWA Electric (Thailand) Co., Ltd.
252/125-126 27th Floor, Tower B Muang Thai-Phatra Complex Building,
Rachadaphisek Road, Huaykwang, Bangkok 10320, Thailand
Phone +66-2693-2200 Fax +66-2693-4200

PT. YASKAWA Electric Indonesia
Secure Building-Gedung B Lantai Dasar & Lantai 1 Jl. Raya Protokol Halim Perdanakusuma,
Jakarta 13610, Indonesia
Phone +62-21-2982-6470 Fax +62-21-2982-6741

Specifications are subject to change without notice
for ongoing product modifications and improvements.